



COMMONWEALTH OF VIRGINIA
STANDARD CONTRACT

Contract No. UCPJMU7423

This contract entered into this 23rd day of April 2026, by Williams Scotsman, Inc., hereinafter called the "Contractor" and Commonwealth of Virginia, James Madison University called the "Purchasing Agency".

WITNESSETH that the Contractor and the Purchasing Agency, in consideration of the mutual covenants, promises and agreements herein contained, agree as follows:

SCOPE OF CONTRACT: The Contractor shall provide the services to the Purchasing Agency as set forth in the Contract Documents.

PERIOD OF PERFORMANCE: From May 3, 2026 through May 2, 2027 with four (4) one-year renewal options.

The contract documents shall consist of:

- (1) This signed form;
- (2) The following portions of the Request for Proposal RFP DKM-1246 dated January 13, 2026
 - (a) The Statement of Needs,
 - (b) The General Terms and Conditions,
 - (c) The Special Terms and Conditions together with any negotiated modifications of those Special Conditions;
 - (d) Addendum No. One - January 29, 2026
- (3) The Contractor's Proposal dated February 8, 2026 and the following negotiated modification to the Proposal, all of which documents are incorporated herein
 - (a) Negotiations Summary, dated March 26, 2026
 - (b) PAC Agreement, dated April 6, 2026

IN WITNESS WHEREOF, the parties have caused this Contract to be duly executed intending to be bound thereby.

CONTRACTOR:

PURCHASING AGENCY:

By: Olivier Gressier
(Signature)
Olivier Gressier
(Printed Name)

By: [Signature]
(Signature)
Aaron Largent
(Printed Name)

Title: VP, General Manager

Title: Buyer Senior

**RFP # DKM-1246, Modular Buildings & Storage
Containers
Negotiation Summary for Williams Scotsman, Inc.
3/26/2026**

1. Contract Pricing:

Storage/Shipping Containers

Container Size	Monthly Rate	Delivery (each way)	Notes
10' Basic Storage Container	\$219.65	\$746.61	
10' Premium Door Container	\$228.05	\$746.61	Easy to open handle
10' Tunnel Container	\$228.05	\$746.61	Doors at both ends
10' Tri-Cam Container	\$228.05	\$746.61	
15' Basic Storage Container	\$236.45	\$746.61	
15' Premium Door Container	\$236.45	\$746.61	Easy to open handle
15' Tunnel Container	\$216.45	\$746.61	Doors at both ends
15' Tri-Cam Container	\$236.45	\$746.61	
18' x 10' Premium Container	\$261.65	\$746.61	Easy to open handle
25' Basic Container	\$273.20	\$746.61	
25' Premium Container	\$283.70	\$746.61	
25' Tunnel Container	\$313.70	\$746.61	
25' Standard Tri-Cam Container	\$273.20	\$746.61	
20' Basic Storage Container	\$195.50	\$746.61	
20' Standard Tri-Cam Container	\$260.60	\$746.61	
20' Tunnel Container	\$311.45	\$746.61	Doors at both ends
20' Premium Door Container	\$274.25	\$746.61	Easy to open handle
40' Basic Storage Container	\$217.55	\$746.61	
40' Standard Tri-Cam Container	\$303.40	\$746.61	
40' Tunnel Container	\$374.20	\$746.61	Doors at both ends
40' Premium Door Container	\$322.00	\$746.61	Easy to open handle
40' Highcube Container	\$275.05	\$746.61	Extra 1' of height

**RFP # DKM-1246, Modular Buildings & Storage
Containers
Negotiation Summary for Williams Scotsman, Inc.
3/26/2026**

Ground Level Offices

Container Size	Monthly Rate	Delivery (each way)	Notes
10' x 8' Ground Level Office	\$732.35	\$746.61	Basic Office Package
18' x 10' Ground Level Office	\$901	\$801.96	Basic Office Package, Basic Café Package
20' x 8' Ground Level Office	\$857.00	\$746.61	Basic Office Package, Basic Café Package
25' x 10' Ground Level Office	\$1,015.20	\$801.96	Basic Office Package, Basic Conference Package
30' Ground Level Office	\$1,107.60	\$801.96	Basic Office Package, Basic Conference Package
40' x 8' Ground Level Office	\$1,116.95	\$746.61	Basic Office Package, Professional Conference Package
20' x 8' Office/Storage Combo	\$681.45	\$746.61	Basic Office Package, Lock
40' x 8' Office/Storage Combo	\$871.10	\$746.61	Basic Office Package, Basic Café Package, Lock

Cold Storage

Container Size	Monthly Rate	Delivery (each way)	Notes
10' x 8' 3-Phase Cold Storage	\$1,211.75	\$1,076.25	
20' x 8' 3-Phase Cold Storage	\$1,477.40	\$1,076.25	
40' x 8' 3-Phase Cold Storage	\$1,567.70	\$1,076.25	

**RFP # DKM-1246, Modular Buildings & Storage
Containers
Negotiation Summary for Williams Scotsman, Inc.
3/26/2026**

Modular Office

Office Size	Monthly Rate	Delivery (each way)	Setup	Knockdown	Notes
24' x 8' Modular Office	\$844.70	\$971.00	\$1,530	\$842	Basic Office Package, Basic Café Package, Steps, Window/Door Security
28' x 8' Modular Office	\$985.60	\$971.00	\$1,530	\$842	Basic Office Package, Basic Café Package, Steps, Window/Door Security
32' x 8' Modular Office	\$1,029.20	\$971.70	\$1,530	\$842	Basic Office Package, Basic Café Package, Steps, Window/Door Security
36' x 10' Modular Office	\$1,391.10	\$1,180.80	\$1,530	\$842	Professional Office Package, Basic Conference Package, Steps, Window/Door Security
44' x 10' Modular Office	\$1,364	\$1,180.80	\$1,530	\$842	Professional Office Package, Basic Conference Package, Steps, Window/Door Security
44' x 12' Modular Office	\$1,632.35	\$1,383.75	\$2,040	\$1,010	Professional Office Package, Professional Conference Package, Steps, Window/Door Security
50' x 10' Modular Office	\$1,751.50	\$1,180.80	\$1,836	\$1,010	Professional Office Package x2, Professional Conference Package, Steps, Window/Door Security
50' x 12' Modular Office	\$1,819.10	\$1,383.75	\$1,836	\$1,010	Professional Office Package x2, Premium Conference Package, Steps, Window/Door Security
50' x 14' Modular Office	\$2,140	\$1,683.65	\$2,040	\$1,010	Professional Office Package x2, Premium Conference Package, Steps, Window/Door Security

**RFP # DKM-1246, Modular Buildings & Storage
Containers
Negotiation Summary for Williams Scotsman, Inc.
3/26/2026**

60' x 12' Modular Office	\$2,019.35	\$1,383.75	\$2,040	\$1,010	Premium Office Package x2, Premium Conference Package, Steps, Window/Door Security
60' x 24' Doublewide Modular Office	\$2,921	\$3,957	\$9,330	\$6,209	Professional Office Package x4, Premium Conference Package, Steps, Window/Door Security
60' x 36' Doublewide Modular Office	\$4,134	\$5,885	\$16,330	\$10,814	Professional Office Package x4, Premium Conference Package, Steps, Window/Door Security

2. The contractor warrants the services under the contract will be performed: (a) in a diligent, professional and workmanlike manner in accordance with the highest applicable industry standards; (b) in accordance with this Agreement and the applicable Statement(s) of Work; and (c) by experienced and qualified personnel.
3. For any purchase excluding from Point-of-Sale purchases, the University will issue an eVA purchase order based upon a quote provided by your firm and the JMU contract number MUST be listed on the quote. No additional agreements, orders forms, or signatures shall be required.
4. Contractor hereby rescinds confidentiality of its entire proposal dated February 8, 2026 and all subsequent negotiations.
5. Contractor acknowledges that all fees have been disclosed. Additional services will be priced based on project and made clear prior to purchase order being issued. No additional fees will be accepted.
6. Contractor shall agree to waive all credit card fees for all purchases related to this contract.
7. Contractor warrants that any leased equipment will be provided in good work order and that services shall exceed industry standards. In the event any leased equipment requires repairs due to a latent defect or Contractor's negligent or willful conduct, contractor shall perform necessary work at contractor expense under this warranty. Other than as stated herein, contractor provides no other warranties.
8. Contractor acknowledges that the VHEPC PAC Agreement, April 6, 2026, shall be incorporated as a part of this contract.

**RFP # DKM-1246, Modular Buildings & Storage
Containers
Negotiation Summary for Williams Scotsman, Inc.
3/26/2026**

9. Contractor acknowledges that all exceptions taken within their initial response to RFP # DKM-1246 that are not specifically addressed within this negotiation/clarification are null and void.

**AGREEMENT
PUBLICLY ACCESSIBLE CONTRACT (PAC)**

This Agreement, effective the 6th day of April 2026, is by and between James Madison University (the "University"), on behalf of the Virginia Higher Education Procurement Consortium (the "Consortium") (collectively the "University"), and Willscot Holdings Corporation DBA Williams Scotsman, Inc., ("Vendor").

The term of this Agreement shall begin May 3, 2026 to May 2, 2027 with 4 – one year renewal options, and an expected final expiration date of May 2, 2031. This end date coincides with the Primary Agreement's UCPJMU7423 end date.

WITNESS

WHEREAS, the University and Vendor have executed an agreement, UCPJMU7423, dated April 23, 2026 (the "Primary Agreement"), and included in the Primary Agreement is a third-party access / cooperative clause. Now therefore, the University and Vendor wish to express in this Agreement the specific terms that will allow third party access to the Primary Agreement.

Accordingly, and in consideration of the mutual premises and provisions hereof, the parties hereby agree as follows:

- I. Vendor will:
 - A. Pay the University 1% of all sales to accessing entities outside of the Consortium membership associated with the Primary Agreement (as the "PAC Annual Fee"). The PAC Annual Fee will be paid in exchange for marketing services provided by the University and the Consortium described below in Section II.
 - B. Fully support this marketing relationship by promoting the availability of the Primary Agreement to non-Consortium entities;
 - C. Provide quarterly sales reports detailing the amount of sales to each non-Consortium accessing entity; and
- II. The University/Consortium will:
 - A. Promote the Primary Agreement on its website and through other channels (e.g., conferences) to non-Consortium members
 - B. Maintain an approved version of Vendor's logo on the Consortium website
- III. Payment:
 - A. Payment of PAC Annual Fee will arrive at the University no later than August 31 of each year. The University and Consortium will share the payments equally and allocate payments to the appropriate accounts.

In the event of early termination of the Primary Agreement, this residual payment will arrive at the University no later than 45 calendar days from termination date of the Primary Agreement.

- B. Payment of PAC Annual Fee will take the form of a check. Checks will be made payable to the University of Virginia and sent to:

Constance Alexander, Office Manager
Procurement and Supplier Diversity Services
University of Virginia, Carruthers Hall
c/o VHEPC
PO Box 400202
1001 N. Emmet Street
Charlottesville, VA 22904

IV. Notices:

Any notice required or permitted to be given under this Agreement will be in writing and will be deemed duly given: (1) if delivered personally, when received; (2) if sent by recognized overnight courier service, on the date of the receipt provided by such courier service; (3) if sent by registered mail, postage prepaid, return receipt requested, on the date shown on the signed receipt; or (4) if sent by electronic mail, when received (as verified by the email date and time) if delivered no later than 4:00 p.m. (receiver's time) on a business day or on the next business day if delivered (as verified by sender's machine) after 4:00 p.m. (receiver's time) on a business day or on a non-business day. All such notices will be addressed to a party at such party's address or facsimile number as shown below.

If to the University:

Procurement Services
c/o Director of Procurement
James Madison University
752 Ott Street, MSC 5720
Harrisonburg, VA 22807

If to Vendor:

Williams Scotsman, Inc.
6400 E. McDowell, Suite 300
Scottsdale, AZ 85257
ATTN: Legal Department
E-mail: Legal@as.willscot.com

ACCEPTANCE

For James Madison University

For Williams Scotsman Inc.

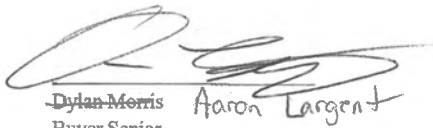

~~Dylan Morris~~
Buyer Senior

Aaron Largent

05/08/20
Date

Olivier Gressier

Olivier Gressier
Vice President, General Manager

05-08-2026
Date

Agreement #: UCPJMU7423-PAC



Proposal For:

James Madison University

Submitted By:

Jacob McGurran - Willscot

Date:

02/08/26



We are WillScot

The industry leader in modular space and portable storage solutions

- + We have the largest fleet, with over 400,000 units available for lease. Countless sizes and configurations that are chosen specifically for the need in question. We have been the industry leader in storage and modular solutions for more than 80 years.
- + With a local team in Roanoke, Virginia, I guarantee a 4-hour response time, and a 48-hour service response time, with most service calls being handled within the first 24 hours. Being local, I can be up at your site in a moment's notice for measurements and guidance on product type and size, free of charge. We have multiple other locations in Virginia, and can ship to any address in the country.
- + Behind our local presence sits a team of internal experts, who are able to manage billing and paperwork items quickly and efficiently.
- + We have the most innovative and diverse solutions with our patented Lock systems, FLEX units and Essentials offering.



We're Driven by One Goal, To Make Your Life Easier.



Unmatched Logistics

Ability to deploy solutions when and where our customers need them, and then remove everything as though we were never there.

Turnkey Space Solutions

From furniture to fixtures to steps and coverage we offer a breadth of solutions to make your space functional right away.

Job Site Essentials

From restrooms, handwashing stations, holding tanks and generators, our team of experts can assist with your site needs.

Turnkey Storage Solutions

Highly-customized storage solutions to help you maximize your space and keep your valuable items secure.



Construction Services

We include in-house Design, Engineering, Pre-Construction and Construction Project Management to ensure high quality facilities are provided in a cost effective, time sensitive and most importantly a safe manner.

- + Experienced Construction Managers will consult with you during the Design, Engineering and Pre-Construction phase to create a cost effective, highly productive function and flow within your fully outfitted building.

- + Our Design & Engineering Professionals assist with floor plan layout, elevation views, renderings and panoramic tours as a means to bring your vision to life and prepare documents for building permit submittals.

- + Highly qualified Project Managers manage the end-to-end construction phase by assessing site conditions, coordinating delivery and installation logistics, validating quality and overseeing safety protocols.

- + The Construction Process starts with a Project Kick-off Meeting to confirm all aspects of the scope, schedule, safety and security requirements. Throughout the installation you will be kept well informed of progress being made followed by a substantial completion punch walk and project close out.

Recent Projects



Lowes Hotel Office Space

7,680 Square Feet 3-Story FLEX Space



Semiconductor Facility in Texas

100,000+ Square Feet Including All Product Categories

Dynamic 3D Designs



Unmatched Logistics





Tri-Cam Storage Containers + Security with Willscot

- + Our Patented Locking System (Tri-Cam) offers the MOST SECURE solution in the storage market.**
- + Standard competitor Containers have bars on the outside of the container. With the right tools, these are frequently broken into with the right tools.**
- + Our patented Tri-Cam Locking System features interlocking bars on the INSIDE of the containers, making break-ins virtually impossible. Ordering through Willscot gives you peace of mind, knowing your product is secure.**
- + To add to the high level of security, we will offer locks, motion-sensing battery-powered lights, and insurance packages (LDW, Contents and General Liability) along with the container. Additional add-ons include Basic Shelving, Pipe Rack, ProRack, Container Ramps.**
- + We also offer tunnel (doors at both ends), Premium Door (easy to open handle) and highcube (extra foot of clearance) containers.**
- + Most Common sizes = 20'x8', 40'x8'. Additional, less common sizes include 10'x8', 15'x8', 18'x10', 25'x10'**



Office Solutions

- + Willscot offers hundreds of styles and configurations, from 20' x 8' Ground Level Offices, up to 100,000 + Square Foot Modular Complexes. We are the industry leader, and can service any need.**
- + Our Offices will come equipped with any furniture package that is needed.**
- + Offices will come pre-wired for data hookups.**
- + Restrooms available in any modular solution, with options to tie directly into plumbing lines, or have serviceable tanks included.**
- + We have done MUCH work with other local education institutions such as Virginia Tech and VMI. We are VERY familiar and comfortable with permitting requirements specific to Universities.**



Storage Container Pricing

Note: Prices will vary by lease term, and configurations. Prices used below are based off of a 1-month lease term, with common added packages and configurations. Monthly rate lowers for longer terms. Delivery costs reflect shipping from Roanoke to JMU's campus.

Storage Container costs will show monthly rate, and delivery costs. Will include cost for full solution – locks, lights, and Loss Damage Waiver. Shelving, Ramps will be extra. Delivery cost always equal to return. No other costs are applicable.

- Note: Spec sheets will be included in bid submission

Storage/Shipping Containers

Container Size	Monthly Rate	Delivery (each way)	Notes
20' Standard Tri-Cam Container	\$260.60	\$746.61	
40' Standard Tri-Cam Container	\$303.40	\$746.61	
20' Tunnel Container	\$311.45	\$746.61	Doors at both ends
40' Tunnel Container	\$374.20	\$746.61	Doors at both ends
20' Premium Door Container	\$274.25	\$746.61	Easy to open handle
40' Premium Door Container	\$322.00	\$746.61	Easy to open handle
40' Highcube Container	\$275.05	\$746.61	Extra 1' of height



Ground Level Office Pricing

Note: Prices will vary by lease term, and configurations. Prices used below are based off of a 12-month lease term, with common added packages and configurations. Delivery costs reflect shipping from Roanoke to JMU's campus.

Ground Level Office costs will show monthly rate, and delivery costs. Will include cost for full solution – office furniture, conference/lunch area furniture, and LDW. Furniture Packages listed in notes can be found in accompanying furniture document. Delivery cost always equal to return. No other costs are applicable.

- Note: Spec sheets of each size will be included in bid submission

Ground Level Offices

Container Size	Monthly Rate	Delivery (each way)	Notes
20' x 8' Ground Level Office	\$857.00	\$746.61	Basic Office Package, Basic Café Package
40' x 8' Ground Level Office	\$1,116.95	\$746.61	Basic Office Package, Professional Conference Package



Modular Office Pricing

Modular Office costs will show monthly rate, delivery, setup and knockdown costs. Will include cost for full solution – office furniture, conference/lunch area furniture, and LDW, Entrance/Steps and Window/Door Security. Very likely costs for specific solution will be lower than what is listed. Furniture Packages listed in notes can be found in accompanying furniture document. Delivery cost always equal to return. Restrooms = extra cost. No other costs are applicable.

Doublewide, Flex, and larger complexes cannot be priced out for bid, as they are too case specific. Costs do not include tax.

- **Note: We have many other modular sizes available. These are the most common. Spec sheets of each listed size will be included in bid submission**

Office Size	Monthly Rate	Delivery (each way)	Setup	Knockdown	Notes
24' x 8' Modular Office	\$844.70	\$971.00	\$1,530	\$842	Basic Office Package, Basic Café Package, Steps, Window/Door Security
32' x 8' Modular Office	\$1,029.20	\$971.70	\$1,530	\$842	Basic Office Package, Basic Café Package, Steps, Window/Door Security
36' x 10' Modular Office	\$1,391.10	\$1,180.80	\$1,530	\$842	Professional Office Package, Basic Conference Package, Steps, Window/Door Security
44' x 12' Modular Office	\$1,632.35	\$1,383.75	\$2,040	\$1,010	Professional Office Package, Professional Conference Package, Steps, Window/Door Security
50' x 10' Modular Office	\$1,751.50	\$1,180.80	\$1,836	\$1,010	Professional Office Package x2, Professional Conference Package, Steps, Window/Door Security
50' x 12' Modular Office	\$1,819.10	\$1,383.75	\$1,836	\$1,010	Professional Office Package x2, Premium Conference Package, Steps, Window/Door Security
60' x 12' Modular Office	\$2,019.35	\$1,383.75	\$2,040	\$1,010	Premium Office Package x2, Premium Conference Package, Steps, Window/Door Security



NOTE: THE SIGNED PROPOSAL AND ALL ATTACHMENTS SHALL BE RETURNED.

In compliance with this Request for Proposal and to all the conditions imposed herein, the undersigned offers and agrees to furnish the goods/services in accordance with the attached signed proposal or as mutually agreed upon by subsequent negotiation.

Name and Address of Firm:

Jacob McGurran - Willscot By: Jacob McGurran
(Signature)

Name: Jacob McGurran
(Please Print)

Date: 02/08/2026 Title: Sales Manager

Web Address: _____ Phone: 540.598.0328 / 540.240.1730

Email: Jacob.mcgurran@willscot.com Fax #: _____

ACKNOWLEDGE RECEIPT OF ADDENDUM: #1 xx #2 _____ #3 _____ #4 _____ #5 _____ (please initial)

This contract entered into this 08 day of 02 2026, by Jacob McGurran, Willscot hereinafter called the "Contractor" and Commonwealth of Virginia, James Madison University called the "Purchasing Agency".

WITNESSETH that the Contractor and the Purchasing Agency, in consideration of the mutual covenants, promises and agreements herein contained, agree as follows:

SCOPE OF CONTRACT: The Contractor shall provide the services to the Purchasing Agency as set forth in the Contract Documents.

PERIOD OF PERFORMANCE: From TBD through TBD

The contract documents shall consist of:

- (1) This signed form;
- (2) The following portions of the Request for Proposals dated 020826:
 - (a) The Statement of Needs,
 - (b) The General Terms and Conditions,
 - (c) The Special Terms and Conditions together with any negotiated modifications of

CONFIDENTIALITY NOTICE: This proposal is for exclusive and confidential use by customer and is the property of WillScot and not to be distributed or copied without written authorization by WillScot.



those Special Conditions;
(d) List each addendum that may be issued

- (3) The Contractor's Proposal dated _____020826_____and the following negotiated modification to the Proposal, all of which documents are incorporated herein.
(a) Negotiations summary dated _____020826_____.

IN WITNESS WHEREOF, the parties have caused this Contract to be duly executed intending to be bound thereby.

CONTRACTOR:

PURCHASING AGENCY:

By: _____JacobMcGurran-Willscot_____

By: _____JacobMcGurran-Willscot_____

(Signature)

(Signature)

(Printed Name)

(Printed Name)

Title: _____Sales Manager_____

Title: _____



Approval and Acceptance of Terms:

Customer Name

Approved By: _____

Date: _____

Print Name: _____

Title: _____

Williams Scotsman, Inc.

Approved By: _____

Date: _____

Print Name: _____

Title: _____

The Industry Leader in Turnkey Modular Space and Portable Storage Solutions



Unmatched Logistics

Ability to deploy solutions when and where our customers need them, and then remove everything as though we were never there.

Turnkey Space Solutions

Multiple options and configurations, combined with furniture, fixtures, steps, coverage and more, can make your workspace functional right away.

Job Site Essentials

From restrooms, handwashing stations, holding tanks and generators, our team of experts can assist with your site needs.

Turnkey Storage Solutions

Highly customized storage solutions to help you maximize your space and keep your valuable items secure.



Everything about our company, from our expert staff to our turnkey solutions to our network of locations, is designed to make it easier for our customers to make one call and get a complete, immediately functional temporary space and storage solution. Our solutions are Ready to Work, so our customers can forget about the space and focus on being safe, comfortable, and productive to achieve their goals.

When the solution is perfect, productivity is all our customers see.

We serve the total site like no one else can.



Our commitment to safety shows a Total Recordable Incident Rate (TRIR) **below 1.0 from 2020 through 1H 2022**



We have the largest fleet, with over **400,000** units available for lease



With over **240+** locations, we can meet any need, anywhere

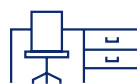

Innovative and diverse solutions with our patented lock systems, FLEX units and Essentials offering

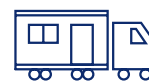

We have more than **800** vehicles ready to deliver when and where customers need them



We have **5,100** local experts standing ready to help customers accomplish their goals



OUR PRODUCT OFFERING

Office Solutions



8' Wide Offices



10' Wide Offices



12' Wide Offices



Double Wide Offices



Complexes



Sales Offices



Blast Resistant Modules



Ground Level Offices



HQ* Offices



FLEX*

Storage Solutions



Standard Width Storage Containers



Extra-Wide Storage Containers



Tunnel Storage Containers

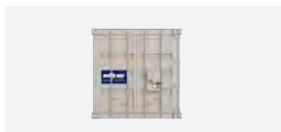

Patented Tri-Cam Locking System & Premium Door options available



Office Storage Combo

Office Essentials



Office Packages



Workstation Packages



Cubicle Packages



Conference Room Packages



Lunch Room Packages



Café Packages



Planning Package



Entrance Packages



Data Package



Protection Plans

Storage Essentials



Locks



Shelving



Pipe Racks

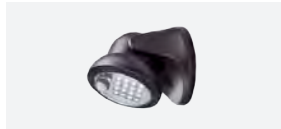

Lighting



Protection Plans

Job Site Essentials



Portable Toilets

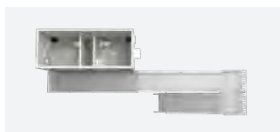

Toilet Trailers



Holding Tanks



Handwashing Stations



Generators



RIGHT FROM THE START



Complete your space

EVERYTHING YOU NEED FOR YOUR SPACE, INSIDE AND OUT

WILLSCOT

TM

SPACE SOLUTIONS | 800.782.1500 | WILLSCOT.COM



One call and you're ready to work

With other providers, when you order an office trailer, that's what you get — an empty trailer. Then it becomes your job to fill it up. Not so with WillScot. We provide the space, plus everything else you need to make it functional right away.

- Working with one source for everything saves valuable time and money.
- We handle ordering, delivery, setup and return, so you can stay focused on your project.
- Eliminate startup headaches by having one consistent offering and one bill. Make one call to us and suddenly you have a lot less to worry about.

EVERY DETAIL, HANDLED

WillScot is the leader in modular workspace solutions. We know temporary space like no other company, and our experts know how to best configure it to meet any need and budget.

We offer a breadth of ready-to-go packages that cover the most typical needs. Plus we provide these packages at multiple levels, from simple, quality furnishings that accommodate your construction teams, to more premium options suitable for entertaining customers and VIPs.

We also offer a full range of items à la carte to finish out your space. You need it? Chances are we've got it.

CONTENTS

Office Packages	7
Conference Room Packages	10
Workstation Packages	15
Cubicle Packages	18
Health & Safety Packages	23
Café Packages	28
Planning Package	33
Media Package	35
Lunch Room Packages	37
Entrance Packages	40
Data Package	45
Portable Storage Units	49
Insurance & Waivers Package	61
À La Carte Items	66

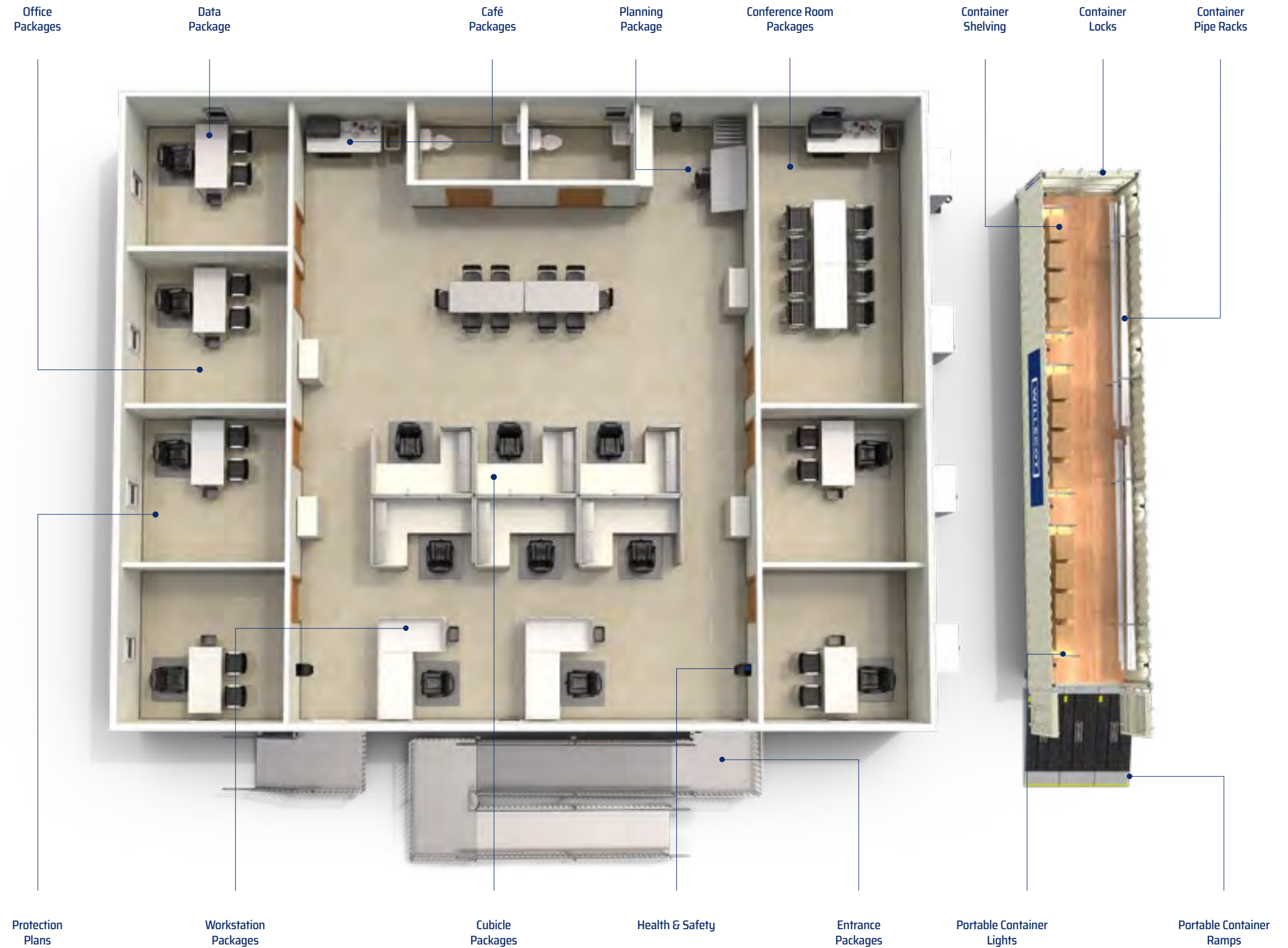



Office Packages

Whether you need a big open-concept workspace or something more private, we can help you create the ideal work environment. Our package levels are designed to fit any need or budget.

PACKAGE LEVELS

	BASIC	PROFESSIONAL	PREMIUM
Standard Desk	1x	1x	
Manager's Chair	1x	1x	
Small White Board	1x	2x	1x
Floor Chair Mat	1x	1x	1x
Small Office Trash Can	1x	1x	1x
Over Door Coat Hook	1x	1x	1x
Premium Office Chair		1x	1x
Stackable Side Chair		2x	2x
3 Drawer Pedestal File Cabinet		1x	2x
Office Supply Starter Kit		1x	1x
Premium "L" Desk			1x



Premium Office



Professional Office



Basic Office



RECOMMENDED ADD-ONS

- A. 50" Flat Screen (pg. 50)
- B. 4 High Bookcase (pg. 48)
- C. Wardrobe/Cupboard Tower (pg. 48)
- D. Modesty Panels* (pg. 46)

*Modesty panels provide privacy below the desk.

Conference Room Packages

WillScot makes it easy for you to create a larger meeting room where your teams can convene and collaborate. Our packages come with everything you need to be productive, from a kitchen space to scalable table options for any sized group.



PACKAGE LEVELS

	BASIC	PROFESSIONAL	PREMIUM
Folding Table	2x		
Folding Chair	4x		
Mini Refrigerator	1x		
Coffee Pot	1x	1x	1x
Microwave	1x	1x	1x
Large White Board	1x	1x	1x
Large Trash Can	1x	1x	1x
Convenience Starter Kit	1x	1x	1x
Standard Desk / Table		2x	
Conference Table			2x
Cafe Table		1x	1x
Manager's Chair		8x	12x
Full Size Refrigerator		1x	1x
Keurig			1x



Premium Conference Room



Professional Conference Room

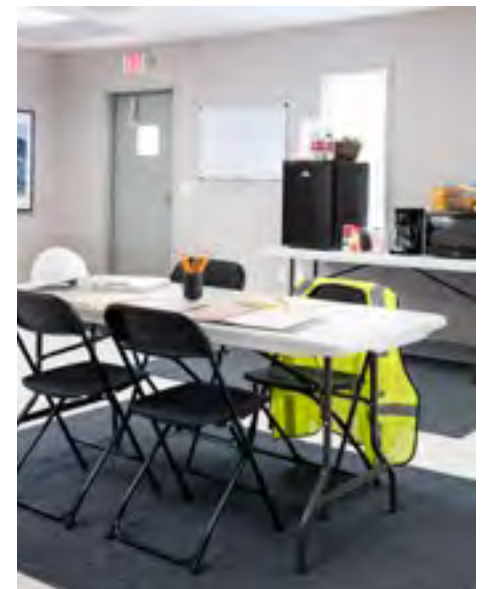

Basic Conference Room



RECOMMENDED ADD-ONS

- A. 50" Flat Screen (pg.50)
- B. 4 Drawer Lateral File Cabinet (pg. 48)
- C. Extra Folding Chairs (pg.47)
- D. Extra Manager's Chairs (pg.47)



Workstation Packages

Create an open working environment that encourages collaboration, while also giving your people the personal space they need to do their jobs. Our packages are built to provide privacy, comfort and tidy cable management.

PACKAGE LEVELS

	BASIC	PROFESSIONAL
Standard Desk / Table	1x	
Manager's Chair	1x	1x
Floor Chair Mat	1x	1x
3 Drawer Pedestal File Cabinet	1x	1x
Small Office Trash Can	1x	1x
Surge Protector	1x	1x
Privacy Shields Around Desk	1x	1x
Modesty Panels Around Desk	1x	1x
Office Supply Starter Kit		1x
Premium "L" Desk		1x



RECOMMENDED ADD-ONS

- A. Electronic Standing Desk (p. 64)
- B. Small White Board (p. 68)
- C. 3 Drawer Pedestal File Cabinet (p. 66)
- D. 4 High Bookcase (p. 66)

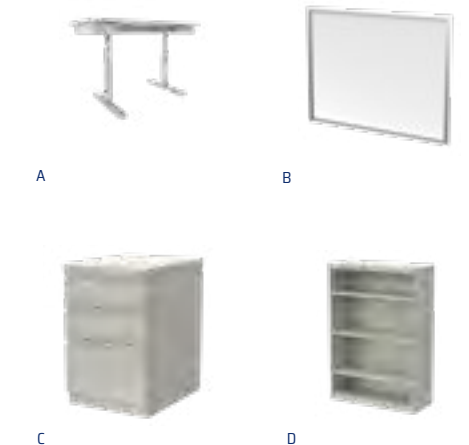

Cubicle Packages

Provide workspace privacy in any configuration with our flexible and scalable cubicle packages. Our unique panel system allows fast, tool-free assembly, accommodates power and data supply, and complements modern WillScot furniture.



PACKAGE LEVELS

	BASIC	PROFESSIONAL
Desk	1x	
Manager's Chair	1x	1x
Pedestal File Cabinet	1x	2x
Small Office Trash Can	1x	1x
Floor Mat	1x	1x
Cubicle Panels	3x	5x
"L" Desk		1x
5 ft Open Shelf		1x



Endless configurations for whatever you may need

Our unique panel system allows fast, tool-free assembly, accommodates power and data supply, and complements modern WillScot furniture.

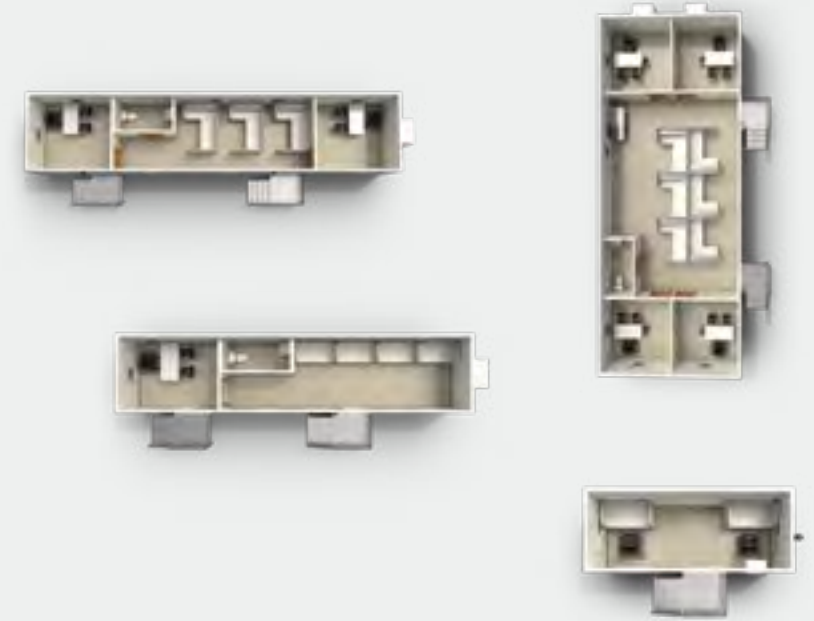

A versatile solution that completes any space

- Clean, modern aesthetic
- Sound dampening panels with tackable walls
- Power and data options available
- Fast, tool-free assembly

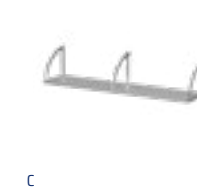

RECOMMENDED ADD-ONS

- A.** 3 Drawer Pedestal File Cabinet
- B.** Power/data pole
- C.** 5 ft. Open Shelf
- D.** Manager's chair



Health & Safety Packages

Keep your people safe, your workspace operational and your company compliant with mandates for sanitation and social distancing. Our line of purifying and protective Essentials has you covered.

BREATHE A LITTLE EASIER WITH OUR INDUSTRY LEADING LINE OF PROTECTIVE PRODUCTS



Extended privacy shields help to divide the space while still allowing light to pass through.



Portable air purification system removes harmful particles throughout your space.

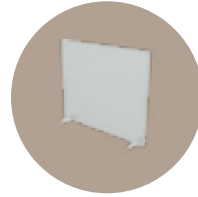

Free standing acrylic protective barriers are a flexible and mobile way to reduce the potential spread of infection.



Conference table protective screens help to keep your meeting space safe and productive.



Acrylic dividers for every area of your space

- Host safe and productive meetings
- Use freestanding shields for temperature check stations
- Taller privacy shields give your employees peace of mind and keep the space open and bright

OUR LINE OF PURIFYING AND PROTECTIVE ESSENTIALS HAS YOU COVERED

PORTABLE AIR PURIFICATION SYSTEM



This revolutionary product incorporates patented DFS technology to efficiently reduce airborne microorganisms and particulate matter.

- WELL and UL2998 Certified
- Capable of 99.99% removal of particles as small as 0.007 micron
- Lightweight, compact, portable construction
- Used in healthcare, government buildings, and military settings.
- Inhibits microorganism growth to extend filter life

ELECTRONIC STANDING DESK



A must-have as your body's needs change throughout the day. The simple up/down controller with memory presets allows you to effortlessly move from seated to standing, and back again.

- Digital keypad w/ three programmable memory settings
- Quiet dual motor design
- 250 lb capacity
- Anti-collision gyro sensor
- 30" x 60" desktop
- ADA & ANSI/BIFMA compliant

FREE STANDING PROTECTIVE BARRIER



Acrylic protective screens are clear, highly transparent and able to withstand repeated cleaning. They are the ideal choice for applications that require durable, washable see-through material for health, reception and safety screens.

- Fits any counter space
- Acrylic durability and superior transparency
- 30.5" W x 23.5" H

EXTENDED PRIVACY SHIELDS



Our extended privacy shields offer privacy and protection from airborne transmission. The panels are frosted allowing light into the workspace. Multiple configurations are available to meet any need.

- Fits WS desks
- Frosted finish
- Added privacy

*Individual particle sizes and specific particle size ranges may have different filtration efficiency rates.

PORTABLE AIR PURIFICATION SYSTEM

INTELLIPURE ULTRAFINE 468

Patented “DFS” Technology delivers advanced air purification with a system specifically designed to capture and reduce ultrafine particles in the air. This revolutionary technology efficiently reduces airborne microorganisms and particulate matter while prolonging filter life by inhibiting the growth of captured microorganisms.

- Efficient air purification to remove VOCs and particles in the indoor environment
- Capable of 99.99% aggregate removal of particles down to 0.007 micron*
- Incorporates patented DFS technology, currently utilized in hospitals, medical clean rooms, government buildings, and military applications



SPECIFICATIONS

- Efficient purification for large spaces
- Weight: 27 lbs
- Dimensions: 13.4” L x 10.6” W x 30.0” H
- Material: All metal housing
- Color: Black

TOTAL SYSTEM PERFORMANCE

- High quality EC motor for low operating costs
- High CFM rate (300 CFM) with low energy consumption
- High CFM rate per decibel level
- Multiple fan speeds for maximum filtration and acoustical control
- Lightweight, compact, portable construction
- Designed for quick, easy filter maintenance and replacement

AREA	CEILING HEIGHT	AIR EXCHANGE	TURBO SETTING	CFM
1125 sq ft	8'	2 hrs	59.2 dB(a)	300
700 sq ft	8'	2 hrs	59.2 dB(a)	300
350 sq ft	8'	2 hrs	59.2 dB(a)	300

*Individual particle sizes and specific particle size ranges may have different filtration efficiency rates.

ELECTRONIC STANDING DESK

A must-have as your body's needs change throughout the day. The simple up/down controller with memory presets allows you to effortlessly move from seated to standing, and back again.

DID YOU KNOW?

Over 60% of employers provide ergonomic standing desks to their employees.

ERGO MADE EASY

Easily upgrade your standard desk to a standing desk in any of our office, workstation, or cubicle packages.

ADA & ANSI/BIFMA compliant



DIGITAL UP/DOWN KEYPAD WITH THREE PROGRAMMABLE MEMORY SETTINGS

30" X 60" WORK SURFACE
Matches seamlessly with full Essentials furniture lineup

27.5" - 44.5" HEIGHT RANGE
For the ideal sit and stand preferences

QUIET DUAL MOTOR DESIGN

- 250 lb lift capacity
- Anti-collision gyro sensor
- Soft start/stop

-9 FT. POWER CORD
For easy plug-in access

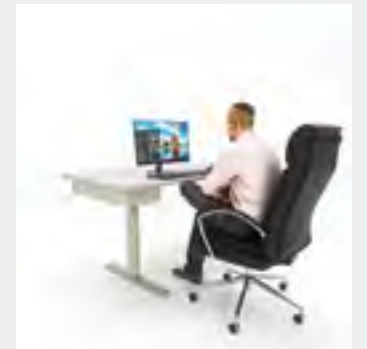
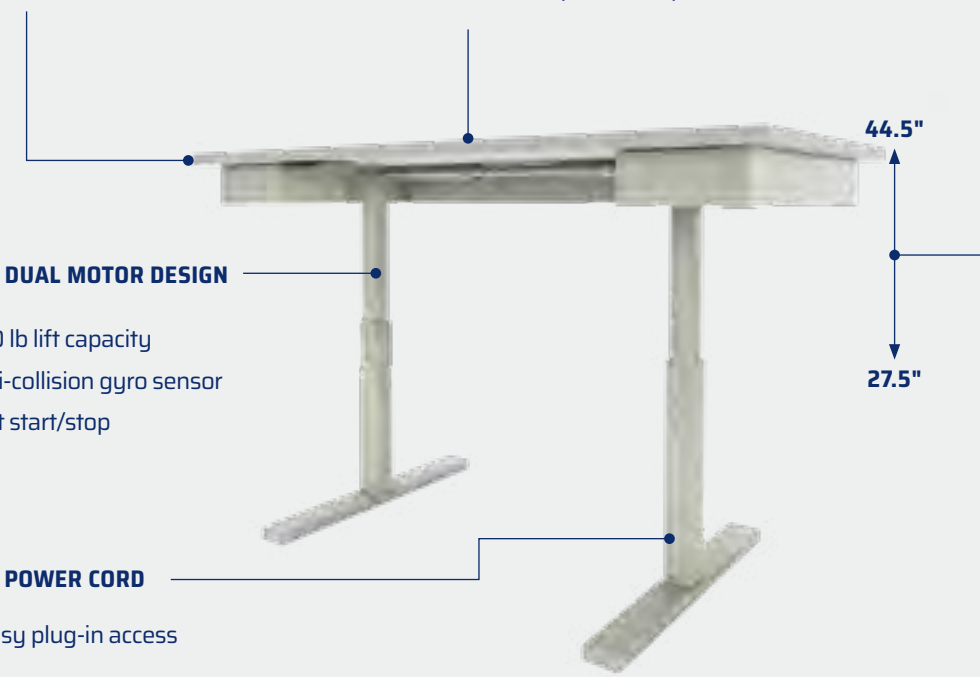

Café Packages

Part of building worksite productivity is making it easy for your people to take a quick break. Our packages allow you to provide a well-outfitted space to grab a coffee, keep snacks cool, and warm up lunch.



PACKAGE LEVELS

	BASIC	PROFESSIONAL
Folding Table	1x	
Mini Refrigerator	1x	
Coffee Pots	1x	1x
Microwave	1x	1x
Convenience Starter Kit	1x	1x
Large Trash Can	1x	1x
Café Table		1x
Full Size Refrigerator		1x
Keurig		1x



Professional Café

RECOMMENDED ADD-ONS

- A. Vented Lockers (p. 66)
- B. Wardrobe / Cupboard Tower (p. 66)
- C. Folding Chairs (p. 65)
- D. Manager's Chairs (p. 65)

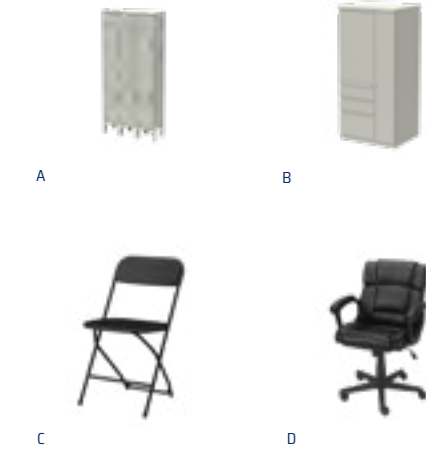

Basic Café

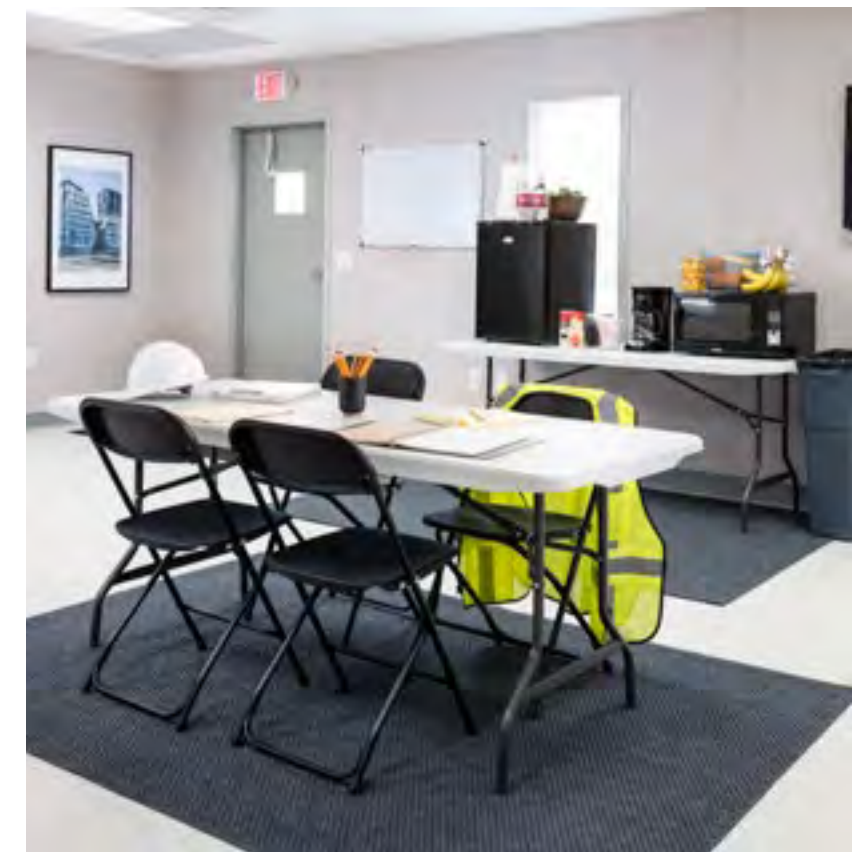

Planning Package

Handling and adjusting large blueprints and other project planning documents can be a challenge at the jobsite. Our package gives you the furnishings and storage space you need to be organized and productive.

PACKAGE LEVELS

	PLANNING
Drafting Table	1x
Rolling Blueprint Rack	1x
Drafting Stool	1x



Adjustable drafting stool swivels 360°



Oversized drafting table provides extra workspace to accommodate larger documents

A



B



C



D



RECOMMENDED ADD-ONS

- A.** 4 Drawer Lateral File Cabinet (p. 66)
- B.** 3 Drawer Pedestal File Cabinet (p. 66)
- C.** 4 High Bookcase
- D.** Wardrobe / Cupboard Tower (p. 66)

Media Package

A necessity for modern-day meeting spaces, and ideal for pure entertainment purposes, our media package means you're Ready To Work (or stream) from day one.

PACKAGE LEVELS

MEDIA PACKAGE - WALL-MOUNT	
50" Smart TV (other sizes available upon request)	1x
HDMI Cable	1x
Tilting TV Wall Bracket	1x

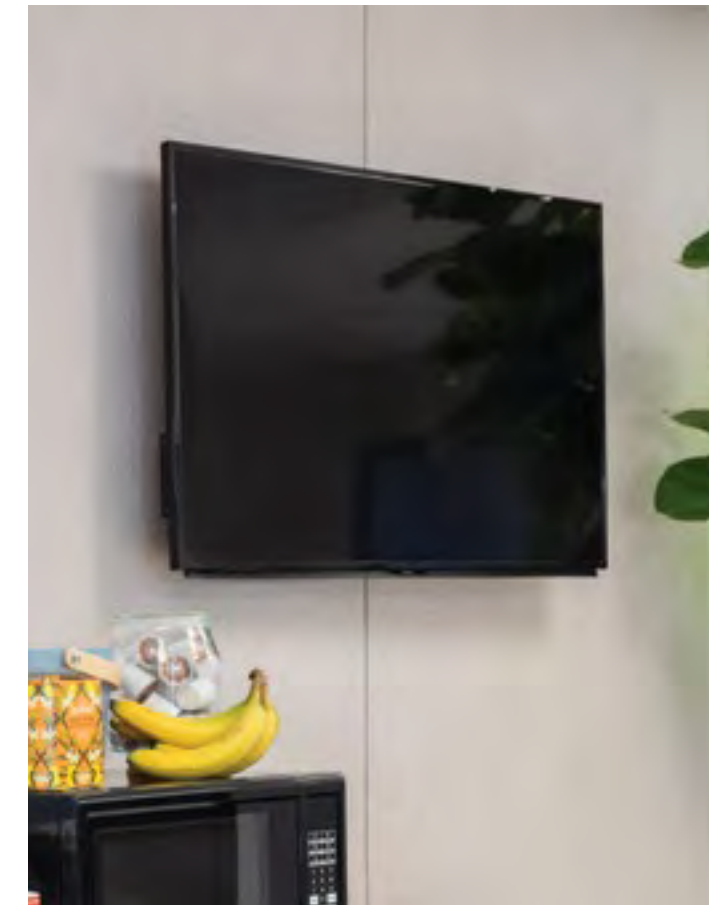

Plug and Play

Installed by our crews and ready to go on day one, you avoid costly wall damages and the hassles associated with self-installation.



BIG SCREEN VISIBILITY & BIG HASSLE SAVINGS

- A. Smart TV (p.68)
- B. HDMI Cable (p. 68)
- C. Media Package - Wall Mount



Lunch Room Packages

A well-appointed lunch area finishes out your workspace and promotes morale and teamwork like no other feature. Our packages provide tables and seating, as well as refrigerator, microwave, and coffee station so your people can refuel, refresh and refocus before going back to work.

PACKAGE LEVELS

	BASIC	PROFESSIONAL
Folding Table	2x	4x
Folding Chair	10x	20x
Large Trash Can	1x	2x
3 Drawer Pedestal File Cabinet		1x
Folding Café Table		1x
Large White Board		1x
Full Size Refrigerator		1x
Coffee Pot		1x
Microwave		2x
Convenience Starter Kit		2x



Basic Lunch Room



Professional Lunch Room

RECOMMENDED ADD-ONS

- A. Media Package - Wall Mount (p. 68)
- B. Vented Lockers (p. 66)
- C. 4 High Bookcase (p. 66)
- D. Wardrobe / Cupboard Tower (p. 66)



A



B



C



D

Entrance Packages

When your mobile office arrives, make sure your people can get into it right away. Our OSHA-compliant packages provide safe, solid, high-grip walking surfaces that you can depend on in any weather, including adjustable steps and treaded platform.



PACKAGE LEVELS

	BASIC	PROFESSIONAL
Stair System	1x	1x
Platform	1x	1x
Boot Scraper	1x	1x
Entrance Mat	1x	1x
Canopy System		1x



Everything we offer is OSHA compliant and set up completely onsite by WillScot.



We have a full range of ADA/IBC compliant step and ramp solutions to meet the needs of your site.

An entrance mat and boot scraper ensures the office stays clean.



Data Hub

Wiring your workspace yourself can cost thousands, create delays and damage the unit. Choosing to have your unit pre-wired saves you money, time and hassle.

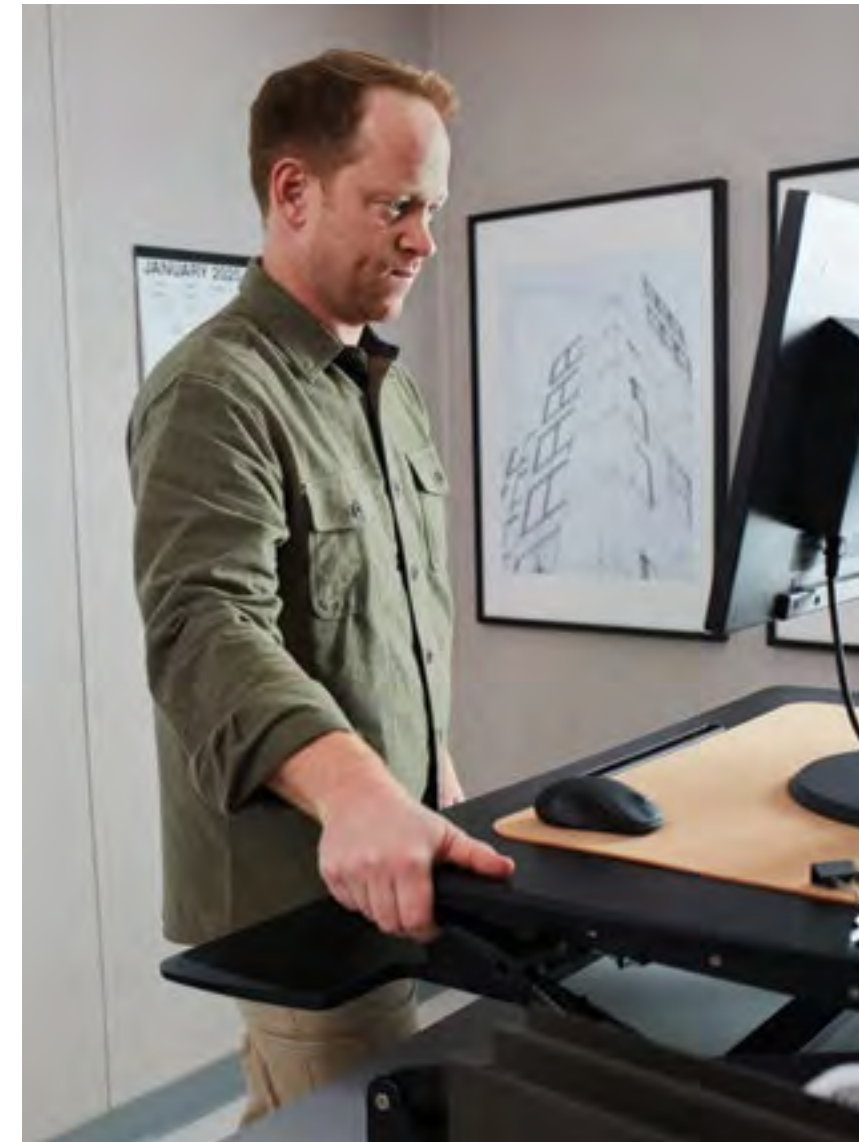

Ethernet Port



Fully Powered Data Switch

RECOMMENDED ADD-ONS

- A. Smart TV (p. 68)
- B. HDMI Cable (p. 68)
- C. Surge Protector (p. 70)
- D. Media Package - Wall Mount (p. 68)

Eliminate downtime by getting your unit wired before delivery

- VoIP-supported data ports in every office and common area
- Single external hook up point for your ISP gets you online faster
- Port placements are fully customizable to your needs



A



B



C



D

SAVE TIME, MONEY AND A WHOLE LOT OF HASSLE

Wiring your workspace yourself can cost thousands, create delays and cause damage. One call to WillScot and you can get modular space that's wired up and ready for business.

	TIME	INSTALLATION	DAMAGE	COST
CALL WILLSCOT	 Unit arrives ready	 Simple ISP hookup	 No Drilling, no damage	 \$100 per month
VS				
DO IT YOURSELF	 2+ weeks to install	 Added time/install for ISP hookup	 Modifications incur damage cost	 ≈\$2,000 cost per floor

A BETTER WAY IN EVERY WAY

EVERYONE'S PRODUCTIVE IMMEDIATELY

Your people can get on the internet and get right to work, and you can focus on more important things than managing a wire-up.

COSTS ARE CONTROLLED

We're much less expensive than hiring a wiring vendor. There's no damage billing on return. And your own people don't have to mess with it.

EVERYTHING WORKS

We pre-test every port, so your unit arrives ready to rock. And if a switch fails, we replace it free. No maintenance, no worries on your part.

YOUR ISP HOOKUP IS PLUG AND PLAY

ISP access points are pre-fitted and ready to be connected on day one. If you have multiple floors, a single demark point can be connected to make your entire space live.



Multiple Port Placements in Every Office and Common Area

- Predetermined port placements are one less thing to think about and ensures you have access where you need it
- Powered data ports fully support VoIP functionality
- Single external ISP hookup point gets you online faster

WHAT'S INCLUDED?

- Min. 6 VoIP capable ports per trailer/unit
- A powered Ethernet switch
- 15" wall enclosure
- Demarcation box for ISP hookup on unit exterior
- All installation and testing of components

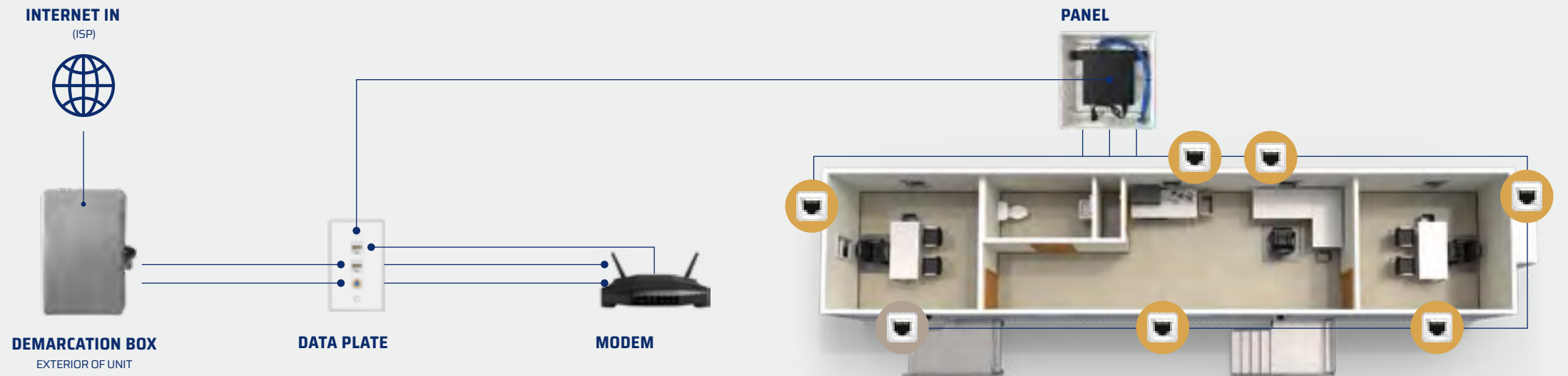

Portable Storage Units

Get the portable storage and accessories you need to keep your operation organized and efficient. From various sizes and door configurations to security options, Mobile Mini provides reliable solutions to all your portable storage needs. Add locks, pipe racks, shelf brackets, lights and more to save precious time and money.

CONFIGURATIONS TO MEET EVERY NEED

Patented Tri-Cam Locking System for vault like security and easy one-handed open access



STANDARD STORAGE CONTAINERS

EXTRA-WIDE STORAGE CONTAINERS

SPECIALTY STORAGE CONTAINERS



Standard width storage containers are ideal for keeping valuable materials, inventory and equipment safe and protected from the elements.



Sometimes two feet of extra width can make an enormous difference. That's why we offer the industry exclusive 10 ft wide storage container. The extra space lets you store pallets side by side with a walkway down the middle for the ultimate in storing convenience.



Our specialty storage containers are ready for whatever big job you throw at them. With doors at both ends, access couldn't be easier making your stored items readily available when you need them.

MULTIPLE DOOR CONFIGURATIONS

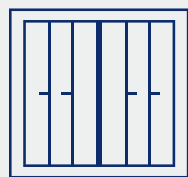

STANDARD DOOR

These are regular doors, which work well for basic storage needs.

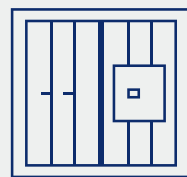

TRI-CAM DOOR

Our patented Tri-Cam Locking System provides bank-vault security with interlocking bars for your precious valuables.

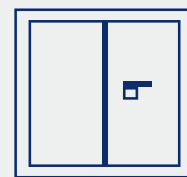

PREMIUM ENTRY

These open easily with one hand so you can get in with minimal effort, especially when you're carrying something.

DOOR OPTIONS



Standard Doors

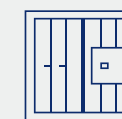

Tri-Cam Doors



Premium Doors

DOOR OPTIONS

Our premium easy open door comes standard on extra wide storage containers.

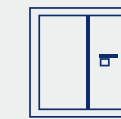

Premium Doors



Standard Doors

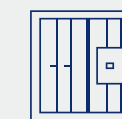

Tri-Cam Doors



Premium Doors

LOCK OPTIONS

The days of finding, buying and managing your own locks are over. Mobile Mini offers a line of durable locks designed specifically to fit our storage and office units, so you can keep your valuables secure.

BASIC PADLOCK



Our most simple locking solution. Works great with all of our units and is a reliable choice for any budget.

- Stainless steel body for maximum strength
- Anti-rust, anti-corrosion and weatherproof
- Hardened steel shackle for best cut resistance
- Durable brass locking cylinder
- Can be keyed alike or different

CONTAINER GUARDLOCK®



This hardened-steel, drill-resistant device has a hidden six-pin tumbler system to keep intruders out.

- Extra secure locking mechanism for high-value items
- Constructed from super-durable materials
- Stands up to harsh weather and extreme temperature
- Won't degrade in wet, dirty or corrosive environments
- Can be keyed alike or different

ENFORCER LOCK



Our maximum-security solution keeps the intruders out and your valuables in.

- Cast steel block protects the padlock from physical attack
- Chrome-plated spring steel lock
- Secured around locking rods with an ABLDY padlock included
- Adjusts in half-inch increments
- Portable and easy to install
- Can be keyed alike or different



DOOR COMPATIBILITY



Standard Doors

Also compatible with Tri-Cam and Premium Doors.

DOOR COMPATIBILITY

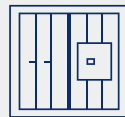

Tri-Cam Doors



Premium Doors

DOOR COMPATIBILITY



Standard Doors

Also compatible with Tri-Cam Doors.



Container GuardLock®

We don't just think our locks work — we know they do

We tested our locks with every tool, material and break-in tactic out there; they're tamper-resistant, bullet-proof and virtually theft-proof. When you rent with us, you can rest assured that no one is getting into your stuff but you. Period.

PRORACK™

Configure Every Inch of Space to Your Needs

Turn your space into exactly what you need with PRORACK: a complete system of sturdy, readily movable surfaces.

Configure it to function as a desk, material storage, pipe rack, tool rack, or a combination of them all. PRORACK optimizes your space like never before.



Durable shelf capacity

The Breakthrough Workspace Management System

- 3 tiers of storage with 300lbs of working load capacity per shelf
- Fully collapsible and configurable panels
- 32-degree configurability for pipe rack storage
- Pre-installed and ready to work on delivery
- Pegboard outfitting for tool organization
- BIFMA and ANSI certified



Adjustable shelving



Workstation



Built-in channels to run cords



Pegboard



Pipe rack

Unleash New Possibilities with Your Space

ENTIRELY FLEXIBLE WORKSPACE

Set up your PRORACK system exactly how you need it. Then when your needs change, shift and shape it to match.

QUICK AND EASY SETUP

PRORACK comes pre-installed in your unit, meaning you can spend less time on setup and more time getting the job done.

ORGANIZE YOUR SPACE

When your space is organized, you can get more done. PRORACK helps you skip the time wasted procuring equipment, because you'll already know where everything is.

MAXIMIZE YOUR CAPACITY

From 200-pound capacity pegboards to 300-pound-per-shelf capacity on surfaces, PRORACK can handle it all, and meets the highest standards of BIFMA and ANSI certification.



AVAILABLE IN 8 FT, 16 FT, 24 FT, AND 32 FT PACKAGE SIZES*

Install PRORACK on one or both sides of the storage container.

*Shelving length may vary slightly

CONTAINER SHELVING



HEAVY DUTY CAPACITY

Each bracket supports up to 1,200 lbs — you might need to find more stuff.



STORAGE FROM FLOOR TO CEILING

Maximize every square inch of your unit with 3 tiers of shelving installed on one or both sides of your container.



READY TO USE

Shelving arrives fully set-up with wood in place.



SIZED FOR ANY NEED

Available in 6 ft, 16 ft and 32 ft package sizes for whatever your site demands.



EASY ACCESS

Use the space underneath to store large items like pallets, ladders and tools.



PIPE RACKING

Add as many as you need for pipes and longer materials of any kind.



Basic Shelving - 32 ft



Pipe Racks



Basic Shelving - 16 ft



A



B



C



D

RECOMMENDED ADD-ONS

- A. Portable Container Lighting (p. 67)
- B. Enforcer Lock (p. 67)
- C. Protection Plans (p. 58)
- D. Pipe Racks (p. 67)

Available in 6 ft, 16 ft and 32 ft package sizes*



PORTABLE CONTAINER LIGHTS



MOTION SENSING

Save energy by having the lights turn on and off only when needed. The sensor beam is adjustable so you can dial in the functionality you want.



ULTRA-BRIGHT LED

Each 600-lumen fixture brightly illuminates its surroundings, so your people can clearly see exterior doors and locks and internal workspaces and supplies.



WEATHERPROOF

With an IP66 dust and water rating, our lights are built to perform through the harshest conditions. Extreme temps, bad weather — the lights stay on.



MAGNETIC

Place lights anywhere you need them, no fasteners required. The magnetic backing readily adheres to our metal storage and office units.



BATTERY OPERATED

Cut the cord and experience ultimate mobility with battery power. No other power connection needed. Expected life with new batteries is 6-12 months, depending on use.



INTERIOR OR EXTERIOR

The same lights can be used inside or out in the elements. They're a quick and easy way to make your whole space bright, secure and functional.



A



B



C



D

RECOMMENDED ADD-ONS

- A. Enforcer Lock (p. 67)
- B. Shelving Brackets (p. 67)
- C. Pipe Racks (p. 67)
- D. Protection Plans (p. 58)



Protection Plans

We make it easy to get the coverage you need for your rental units. Gain peace of mind and the freedom to focus on other priorities.

PROTECTION PLANS



LOSS DAMAGE WAIVER

Waives requirement to cover loss or damage to WillScot-owned units due to vandalism, fire, and acts of God.

FEATURES

Covers up to total replacement cost of WillScot-owned leased unit(s) and Essentials

\$0 deductible

Waives lease requirement to provide proof of property damage insurance

No risk assessment—everyone qualifies



Protection from windstorms and acts of God.



Protection from floods and hurricane damage.



Benefits of our coverage options (even if you have your own insurance)



LOW-COST

- Low monthly cost with \$0 deductibles
- Serves as primary coverage which can act as a stopgap to high deductible plans



EFFICIENT

- Easy to enroll with no prequalification needed
- Managed on a single monthly invoice with leased unit(s)
- Eliminates the need to provide proof of insurance



HASSLE-FREE

- No need to start/cancel - coverage is effective immediately upon delivery and automatically ends with the lease
- No dealing with missing or expired certificate of insurance fees
- No coordination with multiple agencies needed



ZERO PENALTIES

- No premium hikes in the event of a claim
- Protects against cost increases and negative ratings on your existing policy
- Claims do not affect future rental costs or service

WHAT'S COVERED

Electing the Loss Damage Waiver provides you financial peace of mind by covering up to the total replacement value of WillScot-owned units and Essentials should they be lost or damaged due to:



Fire



Earthquakes



Floods



Hurricanes

SIMPLE CLAIMS SUBMITAL PROCESS

- To receive coverage under this plan, a claim must be submitted within 24 hours of knowledge of the event
- Report loss under this coverage due to any criminal act to the appropriate law enforcement authority
- Provide all necessary assistance in processing the claim

Claims Reporting: Your Local Mobile Mini Branch

Direct all waiver related questions and requests to:

WillScot Risk Management Team

4646 E Van Buren St. Suite 400
Phoenix, AZ 85008
(888) 284-0614

willscot.com
RiskManagement@willscot.com

Exclusions: Damages caused by negligence, abuse, wear & tear, or customer modifications. Loss or damage of Lessee property. Damage during transport by Lessee or anyone other than WillScot. Third-party rental services or equipment (e.g. dumpsters, fencing, jiffy-johns, etc.) Other restrictions and limitations may apply - view the addendum at willscot.com/customer-support/terms-conditions.

GENERAL LIABILITY INSURANCE

Protection for third-party bodily injury and property damage claims.

FEATURES
Substantial coverage limits: <ul style="list-style-type: none"> • \$2,000,000 aggregate • \$1,000,000 per occurrence • \$5,000 per person medical coverage (non-classroom units) • \$1,000 per person medical coverage (classroom units)
\$0 deductible; first dollar coverage
Coverage extends to correctly installed entrance packages
"Occurrence Coverage" included - coverage if suit is filed years after lease agreement ends
Waives lease requirement to provide proof of commercial general liability insurance

No risk assessment - everyone qualifies



CONTENTS INSURANCE

Insurance for your stored contents at four affordable tiers of coverage (available for storage containers only).

COVERAGE OPTIONS		
Tier 1	\$2,000 coverage	\$250 deductible
Tier 2	\$5,000 coverage	\$250 deductible
Tier 3	\$10,000 coverage	\$250 deductible
Tier 4	\$20,000 coverage	\$500 deductible

ADDITIONAL COVERAGES

- Up to \$500 for removal/disposal of damaged property
- Up to \$100 for replacement lock



Protect valuable items from theft



Protection from forced entry

WHAT'S COVERED

We've partnered with Allen Insurance Group to offer a general liability insurance program which defends you and pays those amounts you are legally obligated to pay due to third-party bodily injury or third-party property damage arising from occupancy and proper use of a WillScot-owned unit.



Delivery Drivers



Clients



Subcontractors



Students

SIMPLE CLAIMS SUBMITTAL PROCESS

24/7 Claims Reporting
1-800-922-5536

Direct all insurance related questions and requests to:

Allen Insurance
304 Martin Luther King Drive
Fort Valley, GA 31030
1-800-922-5536

allenins.com
postmaster@allenins.com

WHAT'S COVERED

We've partnered with Storage Protectors to offer an AM Best "A+" rated contents insurance program, providing coverage of the property inside the units you lease from Mobile Mini should they be lost or damaged due to:



Burglary



Water Damage



Fire/Smoke



Falling Objects



Mold/Mildew*



Rodents/Pests*

SIMPLE CLAIMS SUBMITTAL PROCESS

- Promptly report any losses under this coverage
- Report loss under this coverage due to any criminal act to the appropriate law enforcement authority
- Provide all necessary assistance in processing the claim

Direct all waiver related questions and requests to:

Storage Protectors
2345 E Thomas Rd, Suite 145
Phoenix, AZ 85016-7848
(833) 659-7867

storageprotectors.com
SP-Questions@carstin.com

Exclusions: Damages caused by negligence, abuse, wear & tear, or customer modifications. Loss or damage of Lessee property. Damage during transport by Lessee or anyone other than WillScot. Third-party rental services or equipment (e.g. dumpsters, fencing, jiffy-johns, etc.) Other restrictions and limitations may apply - view the addendum at willscot.com/customer-support/terms-conditions.

Exclusions: Damage/theft of property not within a fully enclosed and secured unit. Damage due to named storms, floods, or earth movement. Unexplained disappearance. Does not cover various items including firearms, documents, currency, furs, and animals. Not available for third-party managed services or equipment (e.g. dumpsters, fencing, portable toilets, etc.). Other restrictions and limitations apply - view the Addendum and Summary of Coverage documents at MobileMini.com/customer-care/customer-forms.com.

À la carte items

Many of these items are included in our packages, but say you need more desks or chairs or a very specific item to finish out your space. We've got you covered.



DESKS & TABLES



Folding Table

Steel frame with dent, scratch, and rust-resistant surface top. Meets and/or exceeds ANSI/BIFMA performance standards.

72" L x 30" W x 29" H



Standard Desk/Table

Modern design with steel frame and high pressure laminate top for durability. Rear grommet cutout for effective wire management.

60" L x 30" W x 29.5" H



Compact Desk

Smaller size is ideal for space constrained environments. Standard desk offering for FLEX product line.

48" L x 30" W



Premium "L" Desk

Modern design with steel frame and high pressure laminate top for durability. Rear grommet cutout for effective wire management.

90" L x 30" W x 29.5" H



Conference Table

Modern design with steel frame and high pressure laminate top for durability. Center grommet cutout for effective wire management.

72" L x 42" W x 29.5" H



Electronic Standing Desk

Ergonomic sit/stand powered desk with a simple up/down keypad featuring three programmable settings.

60" L x 30" W
Height Range: 27.5" - 44.5"



Adjustable Student Desk w/Bookbox

Adjustable legs suitable for K-12 schools, universities, and training centers. Unique design allows for a wide array of layout options for individual and collaborative work.

Height Range: 19" - 31"

SEATING



Folding Chair

Metal frame holds up to 400 lbs. Folds closed for compact storage and space flexibility.

38.2" H x 17.5" W x 2.5" D closed



Stackable Side Chair

Stacks up to 12 high. Chrome finish. Wood capped arms in walnut finish.

33" H x 22" W x 20.8" D



Drafting Stool

360° swivel with one-touch seat height adjustment. Foot rest and locking casters. Pictured or similar version provided.

55.3" H x 19.25" W x 29.2" D



Manager's Chair

Lumbar support and waterfall seat cushion. Pneumatic seat adjustment.

40.25" H x 25.25" W x 29.5" D



Premium Office Chair

Modern, black synthetic leather upholstery with chrome arms. Pneumatic seat adjustment with tilt lock. Pictured or similar version provided.

46" H x 26" W x 28.5" D



Student Chair - 18"

Most common size ideal for grade 5 through adult classrooms. Designed for comfort, the chair features a modern flowing shape, double-walled textured shell, and non-marring floor glides.

18" H

ACCESSORIES



Privacy Shields

Frosted panels offer privacy while allowing light into the workspace. Multiple configurations to meet any workspace need.

Fit WS desks



Extended Privacy Shields

Frosted panels offer privacy while allowing light into the workspace. Multiple configurations to meet any workspace need.

Sizes: 30" x 30" and 60" x 30"



Modesty Panels

Covers front of desks for added privacy and workspace comfort. Can be installed on any WillScot desk before or after delivery.

Fit WS desks



Conference Table Protective Screen

Acrylic protective shields for use in businesses reduce the potential spread of infection by minimizing aerosol transmission in collaborative environments.

72" W x 24" H



Freestanding Protective Barriers

Acrylic protective screens are the ideal choice for applications that require durable, washable, see-through material for health, reception and safety screens.

30.5" W x 23.5" H



Assembled extended privacy shields and modesty panels.

STORAGE & SHELVING



3 Drawer Pedestal File Cabinet

Two storage drawers and one file drawer. Four casters with wheel locks.

19.75" D x 15.5" W x 23.75" H



4 High Bookcase

Three heavy-duty shelves adjustable at 1/2" increments. Double wall construction for durability.

51.5" H x 36" W x 14" D



5 ft Open Shelf

For use with WillScot cubicles only, this open shelf is a simple and effective solution to organize books, binders and personal items.

60" W x 13" D



2 Drawer Lateral File Cabinet

Locking casters for mobility and space flexibility. Safety interlock system to allow only one drawer to be open at a time.

29.5" H x 30" W x 18" D



4 Drawer Lateral File Cabinet

Safety interlock system to allow only one drawer to be open at a time. Steel ball-bearing drawers with counterweight to prevent tip over.

51.5" H x 36" W x 18" D



Vented Lockers

Lift-up handle accepts pad locks. Vents for visibility and maximum airflow.

15" W x 18" D (multiple configurations available)



Wardrobe/Cupboard Tower

Double wall construction with adjustable side shelves. Side to side coat rod in main compartment.

51.5" x 24" W x 24" D (multiple configurations available)

PORTABLE STORAGE SHELVING, SECURITY & LIGHTING



Shelving Brackets

Quickly and easily maximize your storage space with these heavy duty steel brackets designed for our storage containers.

2,400 lbs gross weight capacity across two brackets (set), spaced approximately 6 ft apart.



Pipe Racks

Single pipe rack bracket with 4 tiers perfect for storing long and narrow materials. Orders must include 2 brackets.

32" tall. 30 degree arm angle. 2 brackets allow for 2200 lbs of loading capacity.



Container Guard Lock

More than a simple padlock, this optional security device features a hidden six-pin tumbler system and is made from hardened steel. It is virtually drill-resistant to keep your items safe and secure.



Basic Padlock

Our most simple locking solution. Works great with all of our units and is a reliable choice for any budget.



Enforcer Lock

Our maximum-security solution keeps intruders out and your valuables in.



Portable Container Lighting

Outside lighting makes your unit visible and secure. Inside lighting makes the interiors bright, inviting and functional. Mobile Mini makes it all super-easy.

APPLIANCES



Mini Refrigerator

Flat zero clearance back and reversible door to fit in a wide variety of spaces. Mechanical temperature control.

2.5 cubic ft interior



Full Size Refrigerator

Upfront temperature controls, incandescent interior lighting and sealed drawers that keep food fresh longer.

14.6 cubic ft interior



Microwave

Digital interface with 6 automatic cooking menus. Non-stick interior for easy clean-up.

1.1 cubic ft



Coffee Pot

Electric slow drip brewing with auto shutoff feature. Non-stick warmer plate.

12-cup



Keurig

3 cup sizes with 48 oz. reservoir to make up to 8 cups between refilling. Auto shutoff feature turns brewer off after 2 hours of non-use.

13.3" H x 9.5" W x 11.4" D



Air Purifier

Portable air purification system that removes harmful particles throughout your space

COLLABORATIVE



Small White Board

Ideal for offices and tight spaces. Ledge for marker storage.

48" L x 36" H



Large White Board

Perfect for conference rooms and common areas. Ledge for marker storage.

72" L x 48" H



Cork Bulletin Board

Prevents damage from hanging materials directly on walls. Natural cork is durable and great for frequent use. Oak finish.

Multiple sizes available.



Smart TV

1080P screen resolution for stunning HD images. Smart TV with built-in access to streaming services.



Drafting Table

Durable frame with adjustable height and desk angle. Full length pencil catch.

60" W



Rolling Blueprint Rack

Adjustable length and height to accommodate various document sizes. Heavy gauge steel construction holds up to 240 lbs.

46" L x 27" W x 66" H

ENTRANCE



OSHA Steps

Fully OSHA compliant. Durable aluminum construction with built-in treads for secure footing in all weather.

Size varies based on unit.



ADA/IBC Compliant Steps

Fully ADA/IBC compliant and customizable to whatever your site demands. Durable aluminum construction with built-in treads for secure footing in all weather.

Size varies based on unit.



ADA/IBC Compliant Ramps

Straight run or switchback systems available. Durable aluminum construction with built-in treads for secure footing in all weather.

Size varies based on unit.



Canopy System

Can be added to any WillScot step or ramp system. Covers entire entrance platform and is rated for 100 PSF snow load.

Size varies based on unit.

All entrance systems are completely installed onsite by WillScot.

ACCESSORIES



HDMI Cable

30AWG high speed HDMI with Ethernet. Supports 4K video resolutions.



Wall Mount

Designed for 37" - 70" displays and tilts from 0° - 10°. Steel construction supports up to 165 lbs.

33.4" L x 1.9" D x 17.3" H



Blueprint Rack Clamps (6 qty)

Sturdy aluminum with solid steel wing knobs accommodate up to 100 sheets or 20 lbs. Transparent label holders included.

Available in 18" - 42" L

ENTRANCE SECURITY



Door Bar

Solid steel bar reinforces entryway and helps protect against intruders. Helps limit access points in larger units.

Size varies base on unit.



Security Screen

Helps protect window from direct impacts. Prevents unwanted entry through unit windows.

Size varies based on window.

ACCESSORIES



Surge Protector

Complete 3-line AC protection. 14 gauge heavy-duty cord.

6 outlets



Floor Chair Mat

Durable plastic protects floors and improves chair movement. Studded version available for carpet.

48" L x 36" W



Power / Data Pole

These attractive and durable poles effectively distribute power and telecommunications wiring to workstations below and can be customized to the needs of your space.

Height varies. 2.5" D



Small Office Trash Can

Convenient size for offices and workstations.

28 qt.



Large Trash Can

Perfect for lunch rooms and common areas. Heavy-duty plastic withstands jobsite abuse.

23 gal.



Small Cubicle Panel

Tackable, sound dampening panel for use with the WillScot cubicle system. Cannot be added as stand-alone item.

30" W x 60" H



Over Door Coat Hook

Ball tips on double steel hook prevent damage to garments. Fits doors up to 1-3/4" thick and holds up to 10 lbs.

8.5" H x 1.5" W x 4.2" D



Boot Scraper

Heavy-duty brush cleans mud, dirt, snow, gravel, rock, leaves, grass, sand, and other debris from all types of footwear. Removes caked-on messes from boot and shoe soles and uppers, saving floors and carpets from debris.

9.4" L x 4.7" W x 4.5" H



Large Cubicle Panel

Tackable, sound dampening panel for use with the WillScot cubicle system. Cannot be added as stand-alone item.

60" W x 60" H



Entrance Mat

GreenTrax high-low scraping design guards against dirt. Durable material withstands harsh weather.

48" L x 36" W



Office Supply Starter Kit

Includes: pens (6), notepads (6), dry-erase marker kit, desk calendar, sticky-notes.

Included in all Professional and Premium Office packages.



Convenience Starter Kit

Includes: ground coffee, filters, stirrers, creamer, sweetener.

Included in all Conference and Café packages.





Get our
packages and
get right to
work

Office Packages

Data Package

Café Packages

Planning Package

Conference Room Packages

Container Shelving

Container Locks

Container Pipe Racks



Protection Plans

Workstation Packages

Cubicle Packages

Health & Safety

Entrance Packages

Portable Container Lights

Portable Container Ramps

Everything you
need for your space,
inside and out.

COMPLETE YOUR SPACE

We offer a breadth of ready-to-go packages that cover the most typical needs. Plus we provide these packages at multiple levels, from simple, quality products that accommodate your construction teams, to more premium options suitable for entertaining customers and VIPs.



RIGHT FROM THE START



FLEX[®]

TEMPORARY SPACE THAT GOES FAR BEYOND ORDINARY

WILLSCOT
TM

SPACE SOLUTIONS | 800.782.1500 | WILLSCOT.COM

A total evolution in temporary workspace

Get modular workspace that's completely flexible to your needs. FLEX® is the ultimate in versatility with nearly unlimited configurations, both inside and out. Connect two units end-to-end and as many as you like side-by-side, then stack up to three stories. Plus, everything you need comes with it, from windows and walls to furnishings and fixtures.



FLEX™

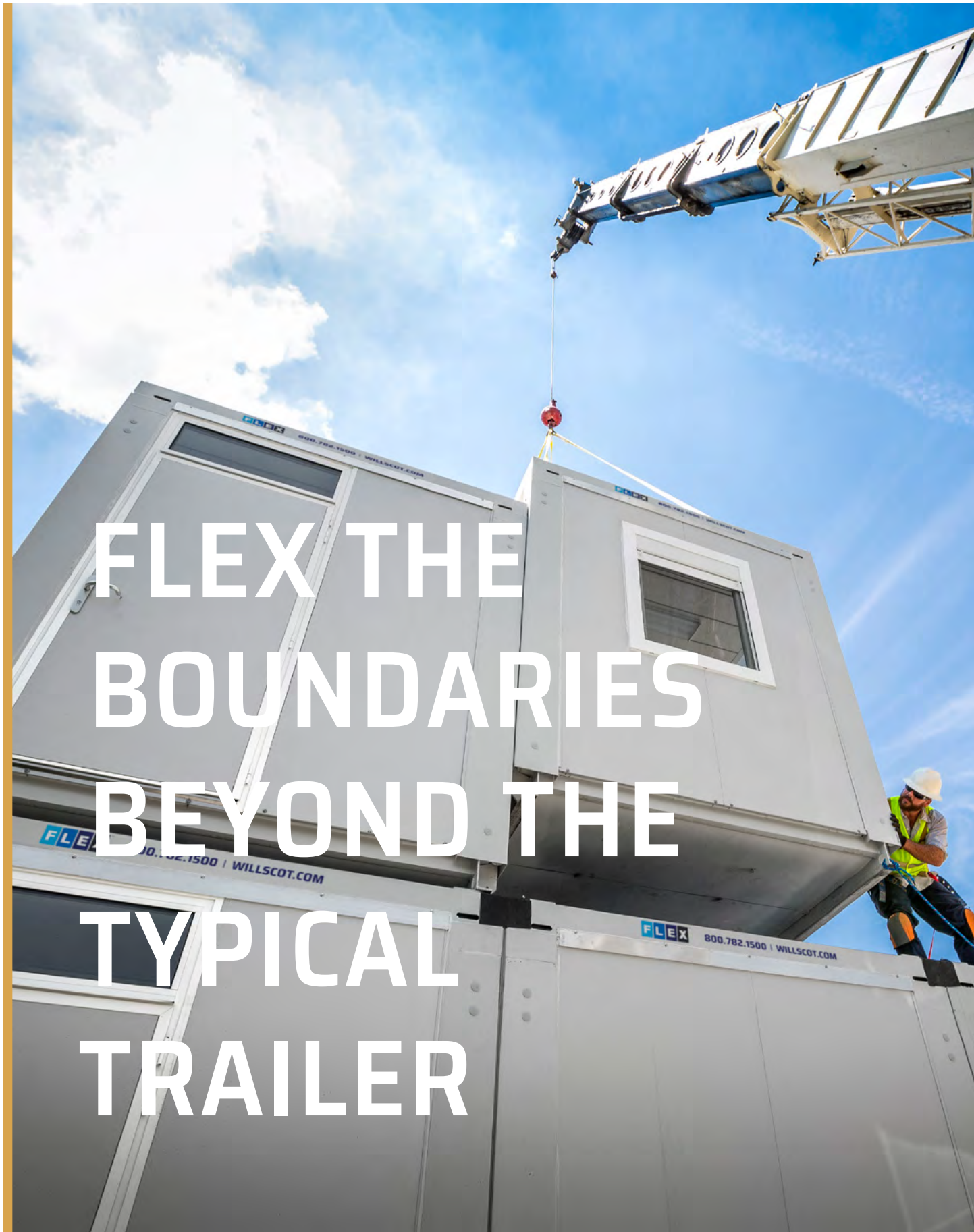

FLEX THE BOUNDARIES BEYOND THE TYPICAL TRAILER



Adaptable footprint

With a single unit only taking up the space of a parking spot, FLEX fits where traditional trailers can't. Connect two units end-to-end, then place as many as you need side-by-side and stack up to three stories. Limited site access? No problem. FLEX units can be lowered by crane into even the tightest, most restrictive spaces — even on top of a skyscraper. No matter what your project calls for, FLEX allows you to put the right space together.



Awesome aesthetics

Unlike traditional trailers, FLEX looks and feels like premium office space — because it is. Every detail is clean and modern, both inside and out. With large windows, sleek steel and glass window panels, contemporary furniture and carpeting, motion-activated LED lighting, flat screen TVs, ADA-compliant stairs, added security, and more, FLEX lets you configure a space that motivates your people and impresses your customers.



Absolute configurability

Movable panels mean you can make your space into whatever you need it to be. Upscale office, entertainment suite, broadcast stage, retail store, locker room, sales center, training room — FLEX does all of this and more. Create wide-open expanses with lots of natural light or configure the space with partitions to separate teams. Make it short, long, thin, wide, small, or tall. With FLEX, there's no shortage of configurations.



Tailored to your specific needs



With FLEX, endless configurability makes it easy to create a workspace tailored to the specific need of your jobsite.





Entrance canopies protect your space and your team from the elements



High-grip surfaces help protect from slipping in any kind of environment

With FLEX, you have the option to add ADA ground-level steps and ramps for first-floor entry, as well as ADA-approved multi-story steps for two- or three-story complexes. These solutions can be accompanied by an optional canopy over the entrance.

ENTRANCES

From ground level to multi-story offices, configure your FLEX units with accessible, fully adjustable ramps and steps that allow your team to get inside on day one.

Choose from a full range of ADA- and OSHA-compliant step and ramp solutions



Access any level of your FLEX complex with step options for two- and three-story offices





FLEX offers a modern, customizable design that provides the utmost flexibility, including door and window placement. WillScot experts assist with arranging these features to meet your needs and adapt as they change, whether that means swapping panels or expanding your unit.

DOOR & WINDOW OPTIONS

Customize your office with the ideal balance of natural light and privacy. Select from various doors and windows to achieve the desired light levels and aesthetic.



STANDARD WINDOW

- Energy-efficient dual-pane tempered glass
- Decreases exterior noise
- Includes blinds for privacy and light control
- Configure with security screens



LARGE FORMAT WINDOW

- More visibility for overseeing job sites
- Energy-efficient dual-pane tempered glass
- Reduces exterior noise
- Includes blinds for privacy and light control

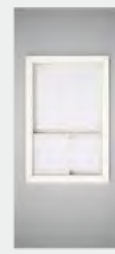

TICKET WINDOW

- Designed specifically for the events industry
- Tempered glass increases window strength
- Can slide horizontal



SECURITY SCREENS

- Provides security from unwanted entry
- Protection from falling objects
- Compatible with standard window



STANDARD DOOR

- Steel construction
- Insulated for proper sound dampening
- Increased level of privacy



LARGE FORMAT DOOR

- Large format windows for increased visibility
- Includes blinds for privacy and light control
- Premium experience for employees and visitors
- Optional double-door configuration available

Large format door



Large format windows

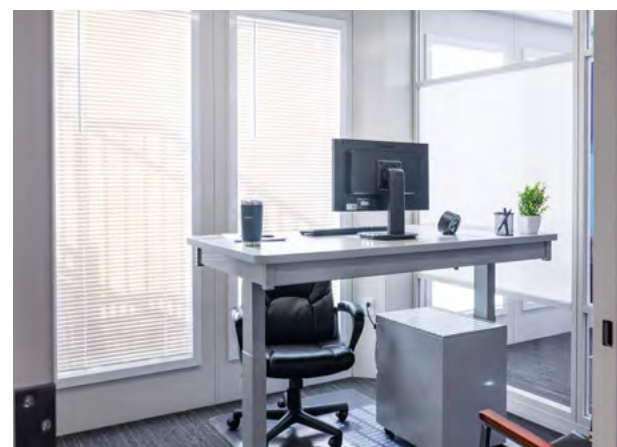



Choose from solid steel panels or upgrade to frosted glass panels for a more upscale aesthetic

Choose from solid steel panels or upgrade to frosted glass panels for a more upscale aesthetic that lets in more natural light. You can even reconfigure the space later, adding or removing panels as your needs change over time. Whatever you need for your office space to be ready to work, FLEX panels can make it happen.

PANEL & WALL CONFIGURATION

The panelized design of FLEX offers limitless partition options so you can customize your space with a sleek, modern aesthetic.

Rolled steel walls allow for hanging with magnets



Frosted panels double as a dry-erase board



THE GLASS PANEL

Modern aesthetic
Allows for the transfer of natural light
Frosted panels also serve as dry-erase board
Allows you to create multiple sizes



THE STEEL PANEL

Insulated panels create proper sound dampening
Rolled steel walls allow for hanging with magnets
Allows you to create spaces in multiple sizes



FLEX 800.782.1500 | WILL



Create a VIP lounge space for a sporting event or concert



High-grip surfaces help protect from slipping in any kind of environment

Equip your FLEX office with ADA-compliant desks on an outdoor deck for meetings and gatherings. This versatile setup can also serve as a VIP lounge for events, enhanced by metal handrails for safety and high-grip surfaces to prevent slipping, ensuring a secure and adaptable environment.

VIEWING DECK

Monitor the jobsite, impress customers, or create an open-air break space with viewing decks for multi-story FLEX buildings.

Configure your FLEX office with ADA-compliant decks for outdoor meetings



Metal handrails keep teams safe during project oversight from the viewing deck





Large magnets attach to the interior and exterior steel panels for even more configurability

Durable steel panels act as a perfect surface for vinyl installation and removal, both inside and out

Maximize your brand's visibility from afar and captivate a wide audience at busy events with custom vinyl wrapping. These wraps provide a unique chance to create a striking impact in any setting.

CUSTOM BRANDING

Make your FLEX office space instantly recognizable to your customers and team members with custom vinyl wrapping that highlights your unique brand.

Wrap seamless branding across large format windows for increased privacy while maintaining full visibility





Media package



Health and safety products

Every office needs furnishings, appliances and accessories to be comfortable and functional. Our Essentials packages fit our floor plans perfectly and outfit your space for immediate productivity, saving you money and time.

COMPLETE YOUR SPACE

Outfit your space with all the essentials so you have everything you need right from the start.

Office packages



Cafe / break room packages



Configurations for every need

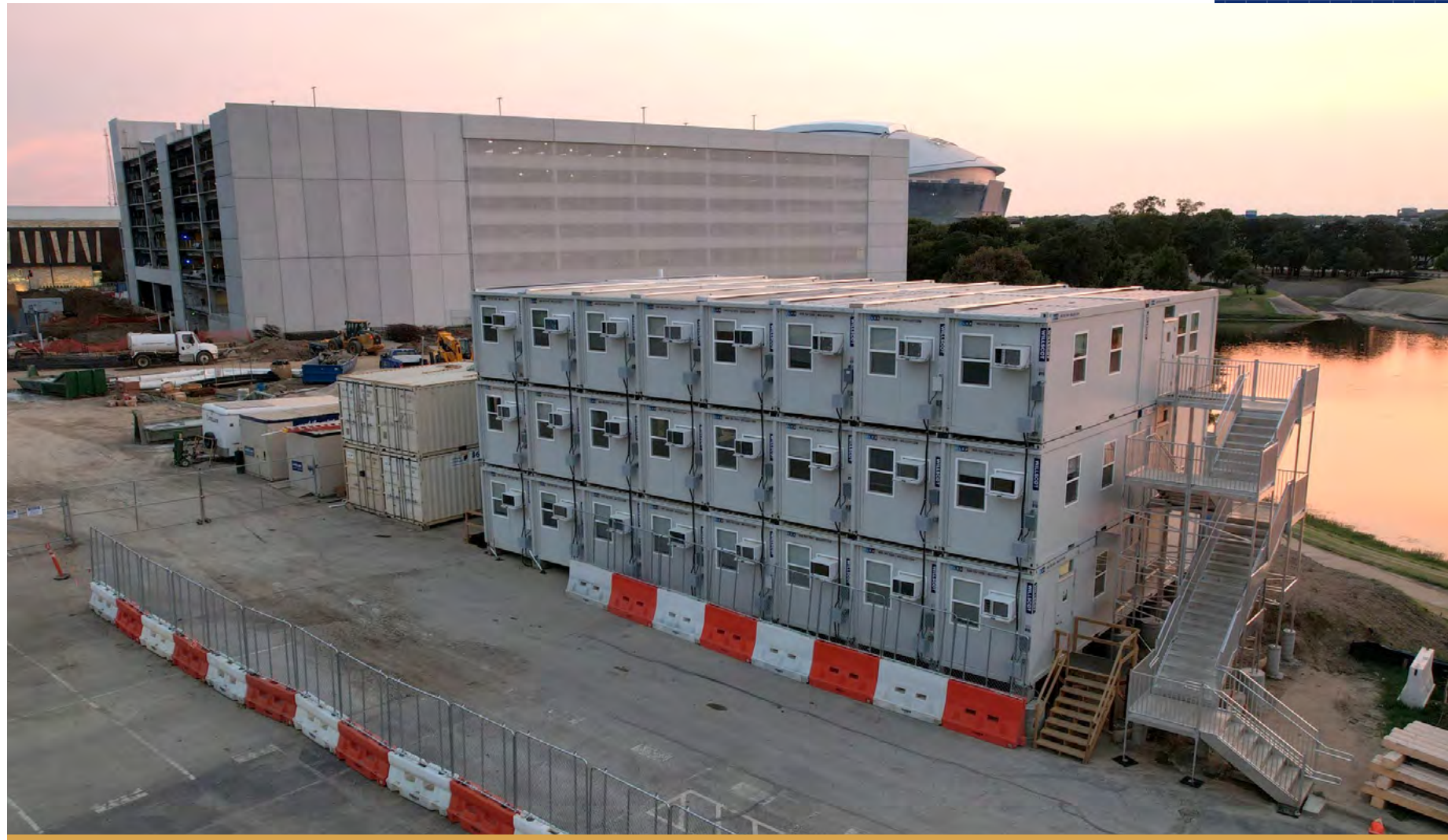

FLEX buildings are the ultimate in versatility. Minimize footprint and maximize space with nearly unlimited configurations and the option to stack up to three stories.

Office Packages

Data Package

Café Packages

Planning Package

Conference Room Packages

Container Shelving

Container Locks

Container Pipe Racks



Protection Plans

Workstation Packages

Cubicle Packages

Health & Safety

Entrance Packages

Portable Container Lights

Portable Storage Units

Everything you need for your space, inside and out.

From simple products that accommodate your construction teams to more premium options suitable for entertaining customers and VIPs, we offer a wide range of ready-to-go packages that cover the most common needs.



RIGHT FROM THE START



Education solutions

WILLSCOT

TM

SPACE SOLUTIONS | 800.782.1500 | WILLSCOT.COM

We can help you create better learning environments

At WillScot, we understand the dynamic challenges schools face, including remodels, rebuilds, and expansions. Educational institutions from pre-K to college rely on us for premium portable structures, ensuring minimal disruption and optimal learning conditions. Our mission is to provide the necessary space solutions for students, teachers, staff, and visitors, allowing educational entities to concentrate on the crucial task of fostering academic growth.



WE MAKE YOUR LIFE EASIER

As North America's largest provider of modular space, we have exactly the right units for your builds, special projects or expansion plans, ready to roll to any location. One call and you get the buildings and storage you need, complete with all the furnishings, fixtures, technology, security and more to make your space right from the start. We take care of every detail for you, so you can keep delivering on your mission to educate.



USES FOR SCHOOLS

- | | |
|--------------------------------|----------------------|
| Administrative offices | Libraries |
| Computer labs | Nursing clinics |
| Conference rooms | Restrooms |
| Daycare facilities | Science labs |
| Equipment storage | Security buildings |
| Faculty lounges | Study halls |
| Furniture and supplies storage | Temporary classrooms |
| | Visitor centers |



READY SOLUTIONS FOR SCHOOLS AT ANY LEVEL

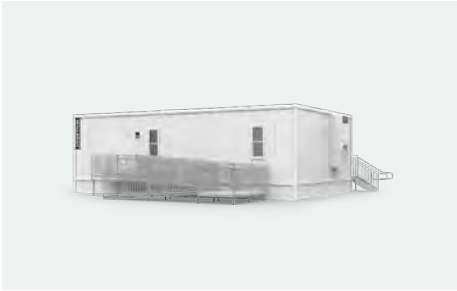

PORTABLE CLASSROOMS

Minimize educational disruptions and ensure students continue to learn

Units provide a safe environment amid post-disaster challenges

We can provide ramps, stairs, desks, whiteboards, internet connectivity and more

Units can also function as admin offices, computer labs, libraries and more



FLEX®

Innovative, stackable modular offices that maximize space utilization on campus

Our fleet is new or like-new and readily available for fast deployment anywhere you need

Flexibly adapt to your evolving space requirements by adding or removing units as needed

Higher efficiency and less energy use than traditional mobile buildings



MOBILE OFFICES

Our full range of units lets you set up and organize educational activities quickly and efficiently

Create a central office, faculty lounge, nursing station or anything else you need

We can provide all the furnishings and fixtures so you can use the space immediately

Maintain a clean working environment with our air purifiers and other appliances



GROUND-LEVEL OFFICES

Ready-to-go container configuration gets you set up and functioning fast

Our units can be placed in the tightest of spaces anywhere on your campus

Shipping-container construction stands up to harsh weather and heavy usage

We can deliver the unit pre-furnished with the necessary fixtures



STORAGE CONTAINERS

Secure weather-resistant units to protect equipment, supplies, furniture and more

Units can be easily transported, relocated or reconfigured to meet your changing needs

Fits on a single parking spot and can be brightly lit with motion-activated magnetic lights

Durable hidden-tumbler locks keep all of your valuable contents secure



CLIMATE CONTROLLED STORAGE

Reliable cold storage solutions to keep your food and beverages fresh and chilled

All units are equipped with adjustable thermostats to easily manage and monitor temperatures

Available in various sizes, allowing you to choose the perfect solution for your events

NSF certified units provide the highest standard of hygiene and safety for your event

Office Packages

Data Package

Café Packages

Planning Package

Conference Room Packages

Container Shelving

Container Locks

Container Pipe Racks



Protection Plans

Workstation Packages

Cubicle Packages

Health & Safety

Entrance Packages

Portable Container Lights

Container Ramps

Portable Storage Units

Everything you need for your space, inside and out.

Creating a functional classroom involves more than simply providing an empty space. To ensure your space is immediately conducive to education, we provide a comprehensive range of ready-to-use packages- designed to meet the most common needs, equipping your classroom for success right from the start.





COLORADO ACADEMY CLASSROOMS / OFFICES

Solution Type

Instructional

Scope of Project

18,700 ft²

Time to Occupancy

43 Days



THE STORY

LAKWOOD, CO



Colorado Academy, a private school in Jefferson County, Colorado, was in the process of having a brand new high school built. They needed temporary space for more than 300 students and office space for approximately 20 teacher and administrators for approximately a 7-month term during construction of the new school.

Colorado Academy needed temporary space for their students during construction. We worked with the school's general contractor to have temporary classrooms in place and ready for occupancy before the start of the school year.

We met with Colorado Academy, their architect, general contractor and subcontractors numerous times prior to delivery to assist with the permit process, determine the optimum area of campus to install our buildings, and to ensure that everyone agreed on the scope of work for each party.



COLORADO ACADEMY

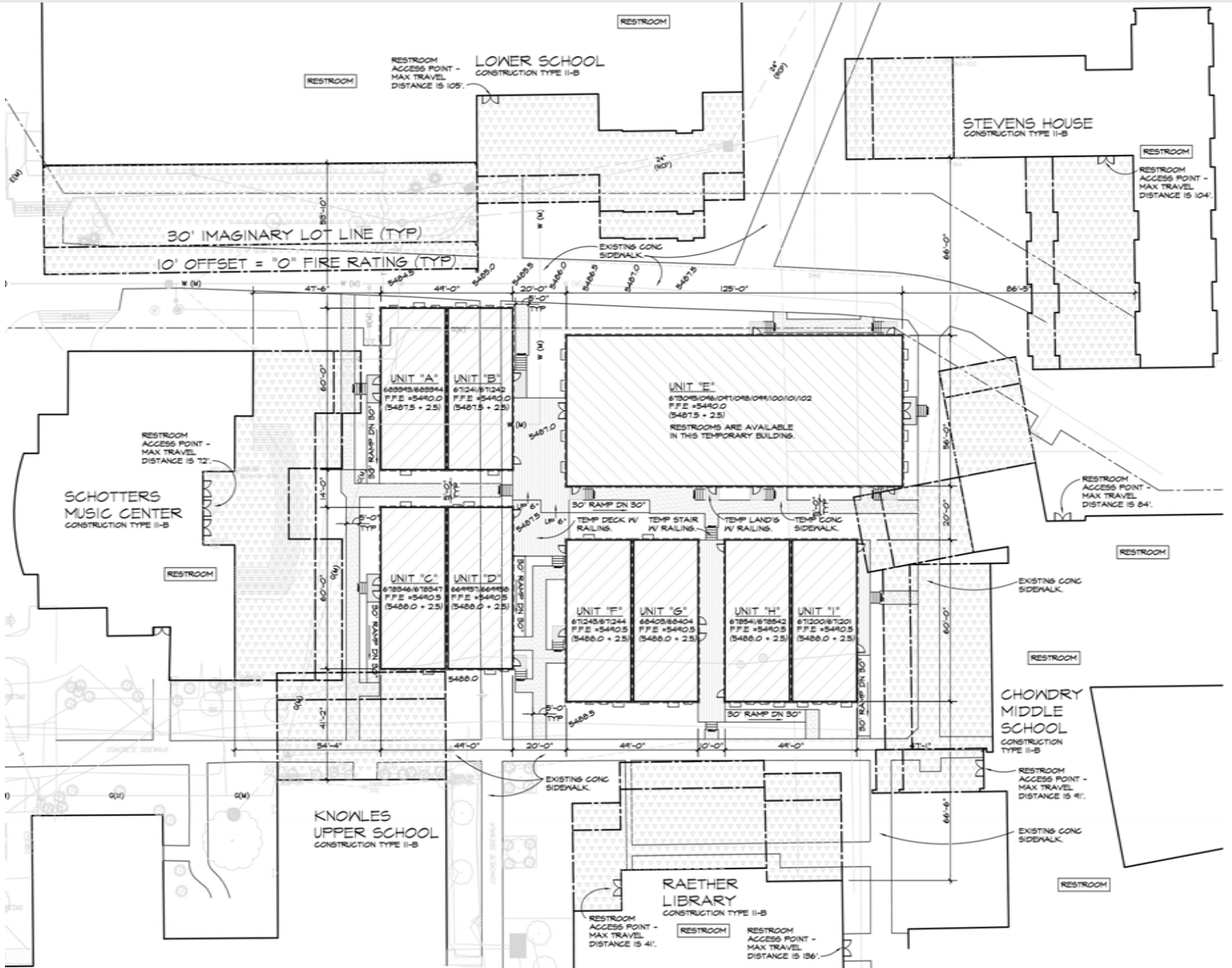

We provided eight 24' x 60' modular classrooms and one 56' x 128' classroom and administrative complex. The buildings were prepared at the local branch while Colorado Academy's general contractor prepared the site. Once the site was ready, our team delivered and set more than 18,000 square feet of buildings, including decks and handicapped ramps, in 43 days.

* Photos are representational; actual products vary.
Additional floor plans and specifications may vary from those shown and are subject to in-stock availability



LOYOLA UNIVERSITY SOCIAL DISTANCE CLASSROOM SPACE

Solution Type

Education /
Disaster Relief

Scope of Project

21,600 ft²

Time to Occupancy

45 Days



THE STORY

BALTIMORE, MD



Challenge

At the start of the COVID-19 pandemic in the U.S., Loyola University Maryland, a private university in Baltimore, was in need of extra space for social distancing in their classrooms. After receiving a recommendation from one of their contractors, the university partnered with our local Baltimore team for a temporary classroom solution.

Solution

The WillScot Construction Services Division developed a plan to install 30 modular classroom buildings on Loyola's multi-purpose field adjacent to the university's student center and bookstore.

The 30 modular buildings were arranged into 5 separate 6-building complexes, each comprised of 2 classrooms that could safely hold 35 students spaced 6 feet apart. The 10 total classrooms were connected with a series of walkways to provide students convenient access to the classrooms and bookstore. Additionally, each classroom was equipped with enhanced audio and video technology to help students start learning from day one.



WILLSCOT

TM

PENN STATE BOOKSTORE UNIVERSITY BOOKSTORE

Solution Type

Instructional

Scope of Project

20,000 ft²

Time to Occupancy

49 Days

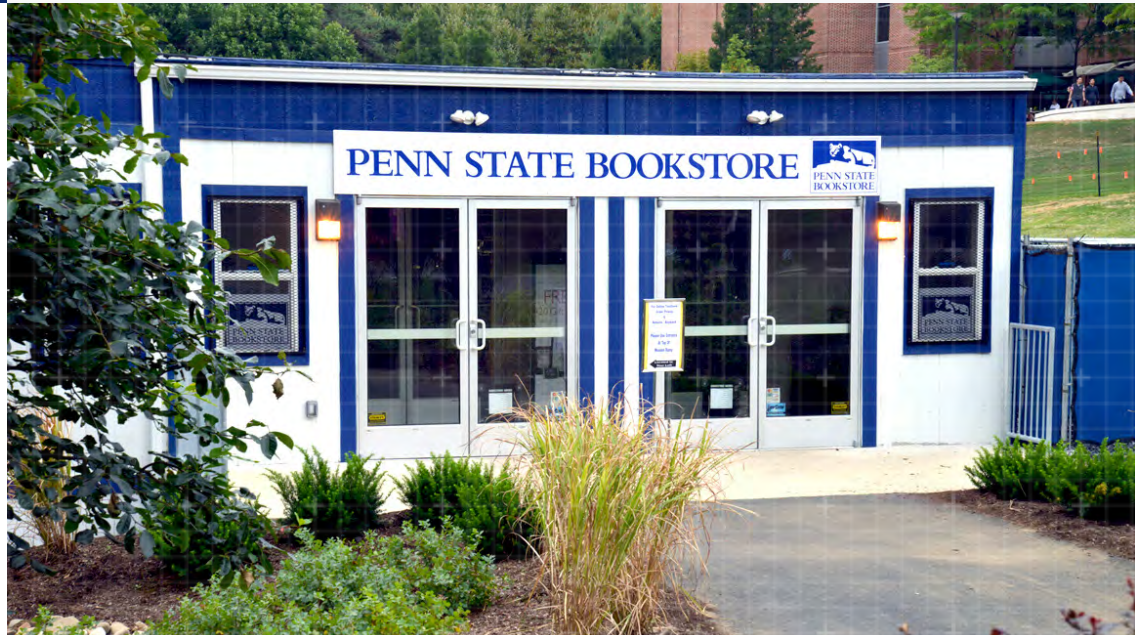

THE STORY

UNIVERSITY PARK, PA

+

Penn State University in University Park, PA needed a temporary bookstore while their existing bookstore was closed for a 2-year renovation. The facility had to be easily accessible by students on campus and ready before students returned for the fall semester.

We worked with general contractor Gilbane Building Company and PSU representatives to find an appropriate location adjacent to the existing bookstore. Timing was tight, so a 28-unit modular complex was selected from our existing fleet. The buildings underwent a thorough renovation process. Onsite they were installed 14-units deep by two-units wide to make the most of the available space. The building was structurally reinforced to manage the enormous weight load of the books plus the expected

flood of students. The drop ceiling was removed, exposing an overhead network of steel trusses. The 11-foot ceiling creates a more airy feeling throughout the store.

Placing the building on campus in an unused space adjacent to the existing bookstore allowed Penn State and bookstore operator, Barnes & Noble, to keep construction on track when students arrived for the new school year.

800.782.1500 | WILLSCOT.COM



UNIVERSITY OF SAN DIEGO LAW SCHOOL

Solution Type

Educational
Administrative
Space

Scope of Project

18,000 ft²

Time to Occupancy

45 Days



THE STORY

SAN DIEGO, CA



Challenge

The University of San Diego was in need of administrative swing space for their staff while their law school administrative building was under renovation. The university was particularly interested in a total site solution that included temporary office space, furniture and decking to help their staff be ready to work from day one.

Solution

WillScot's San Diego team provided 26 modular buildings, including a toilet trailer and 25 mobile offices that were configured into four buildings on a campus parking lot near the law school. The WillScot team also supplied premium office and conference packages that included chairs, desks, filing cabinets, office supplies, white boards, a

refrigerator, a café table, a microwave, trash cans and even a coffee pot that allowed university staff to be fully prepared before school started.

This project was unique as it required a total site solution that was both safe and flexible enough to fit within the parking space near the law school. The WillScot San Diego team was able to deliver a safe modular solution that fulfilled all the university's needs allowing their team to get right to work.



Redacted:

Pages 85-103

**(Bidders Application
Information Package)**

RIGHT FROM THE START



20' x 8' Storage Container

Our 20' conex box is a popular choice for large seasonal storage, construction storage, remodeling projects, and more.

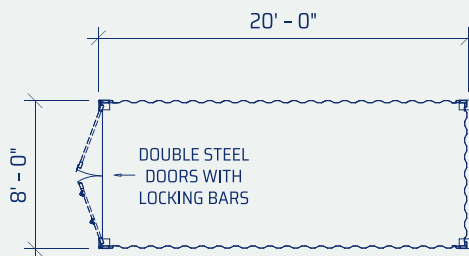

Complete Your Space

- Lighting
- Shelving & Pipe Racks
- Ramps
- Locks
- Protection Plans

INTERNAL

7' 8-1/2" W

19' 10-1/2" L

7' 10-1/4" H

Volume: 1203 cubic feet

EXTERNAL

8' W

20' L

8' 6" H

Volume: 1360 cubic feet

QUALITY

100% corrugated, all-steel container

Weather-resistant

SECURITY

Container Guardlock (optional)

Tri-cam locking system

DOOR OPTIONS



STANDARD DOOR

These are regular doors, which work well for basic storage needs.

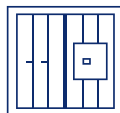

TRI-CAM DOOR

Our patented Tri-Cam Locking System provides bank-vault security with interlocking bars for your precious valuables.



PREMIUM DOOR

These open easily with one hand so you can get in with minimal effort, especially when you're carrying something.

WILLSCOT

TM

SPACE SOLUTIONS | 800.782.1500 | WILLSCOT.COM

RIGHT FROM THE START



40' x 8' Storage Container

The 40' conex container is our largest standard storage container and allows you to store all of your large equipment, supplies, and inventory neatly and securely onsite.

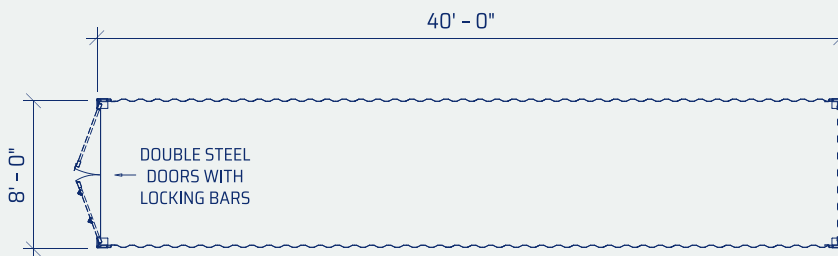

Complete Your Space

- Lighting
- Shelving & Pipe Racks
- Ramps
- Locks
- Protection Plans

INTERNAL

7' 8-1/2" W

39' 10-1/2" L

7' 10-1/4" H

Volume: 2,414 cubic feet

EXTERNAL

8' W

40' L

8' 6" H

Volume: 2,720 cubic feet

QUALITY

100% corrugated, all-steel container

Weather-resistant

SECURITY

Container Guardlock (optional)

Tri-cam locking system

DOOR OPTIONS



STANDARD DOOR

These are regular doors, which work well for basic storage needs.

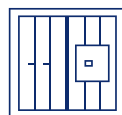

TRI-CAM DOOR

Our patented Tri-Cam Locking System provides bank-vault security with interlocking bars for your precious valuables.

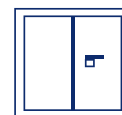

PREMIUM DOOR

These open easily with one hand so you can get in with minimal effort, especially when you're carrying something.

WILLSCOT

TM

SPACE SOLUTIONS | 800.782.1500 | WILLSCOT.COM

RIGHT FROM THE START



40' x 8' Tunnel Storage Container

Our tunnel storage containers are ready for whatever big job you throw at them. With doors at both ends, access couldn't be easier making your stored items readily available when you need them.

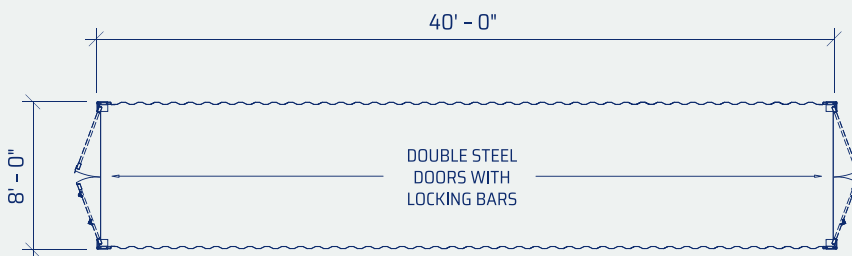

Complete Your Space

- Lighting
- Shelving & Pipe Racks
- Ramps
- Locks
- Protection Plans

INTERNAL

7' 8-1/2" W

39' 10-1/2" L

7' 10-1/4" H

Volume: 2,414 cubic feet

EXTERNAL

8' W

40' L

8' 6" H

Volume: 2,720 cubic feet

QUALITY

100% corrugated, all-steel container

Weather-resistant

SECURITY

Container Guardlock (optional)

Tri-cam locking system

DOOR OPTIONS



STANDARD DOOR

These are regular doors, which work well for basic storage needs.

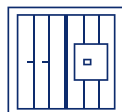

TRI-CAM DOOR

Our patented Tri-Cam Locking System provides bank-vault security with interlocking bars for your precious valuables.

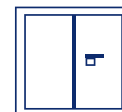

PREMIUM DOOR

These open easily with one hand so you can get in with minimal effort, especially when you're carrying something.

WILLSCOT

TM

SPACE SOLUTIONS | 800.782.1500 | WILLSCOT.COM

RIGHT FROM THE START

PREMIUM DOOR CONTAINERS

Containers with premium doors for security and convenience



SIZING

Width - 8' (7' 8.5" internally)
Lengths - 10' - 40'
Height - 8' 6" (7' 10.25" internally)

FEATURES

One-hand access for ease and convenience
Includes our patented Tri-Cam locking system
All-steel, weather-resistant container
Single end entry, double doors (dual end entry doors also available)
Shelving, lighting and locks available for a fully functional storage space from day one

OUR SPECIALTY STORAGE CONTAINERS

Extra-wide containers can hold large equipment or two side-by-side pallets with a corridor between them. Tunnel storage containers, with doors at both ends, offer easier access, ideal for retail and warehousing. High-cube containers provide extra height for tall equipment or supplies.

USES

Construction tools, materials, and equipment
Seasonal supplies
Playground and athletic gear
Retail inventory
Office furniture & supplies during renovations
Secure document storage



Includes Tri-Cam locking system



One hand accessibility



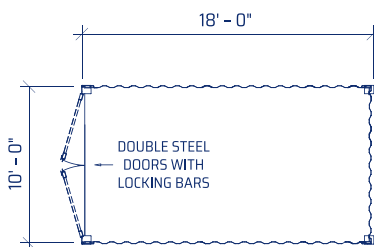
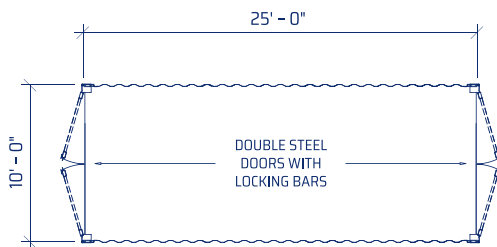
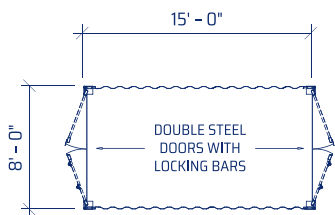
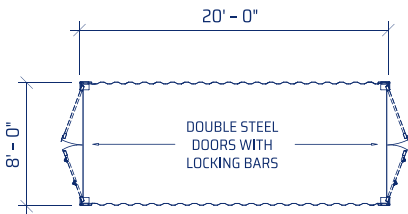
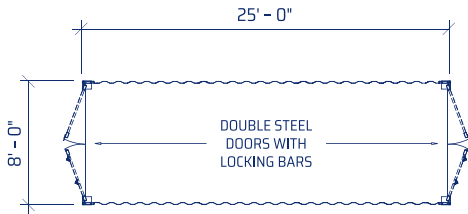
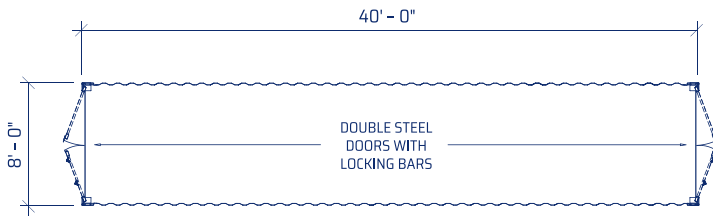

PREMIUM CONTAINER FLOORPLANS

We offer a wide selection of sizes that meet a variety of portable storage needs.

Our rugged storage containers provide industry-leading technology and innovative solutions, providing security and convenient access for equipment and materials wherever you need it.

We also provide a variety of additional products, including locks, lighting, ramps, shelving, pipe racks and protection plans, thoughtfully designed to fit your space, saving you time and money, so that your space is outfitted with everything you need, right from the start.

* Photos are representational; actual products vary. Additional floor plans and specifications may vary from those shown and are subject to in-stock availability

WILLSCOT

TM

SPACE SOLUTIONS | 800.782.1500 | WILLSCOT.COM

RIGHT FROM THE START



24' x 8' Mobile Office

Our 24' x 8' job site trailer provides 160 sq. ft. of mobile office space and is made with durable, high-quality materials that meet national and state building, electrical, mechanical and plumbing codes.

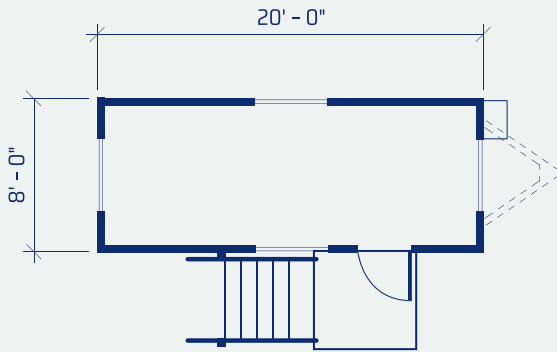

Complete Your Space

- Steps & Ramps
- Furniture & Appliances
- Technology
- Site Services
- Protection Plans

DIMENSIONS

24' Long (including hitch)
20' Box size
8' Wide
7' Ceiling height

EXTERIOR FINISH

Aluminum or wood siding
I-beam frame
Standard drip rail gutters

INTERIOR FINISH

Gypsum ceiling
Paneled walls
Vinyl tile floor

ELECTRIC

Flourescent ceiling lights
Breaker panel

HEATING/COOLING

Electric baseboard heat and
thru-wall AC unit or
combination heat/AC unit

WINDOWS / DOORS

Horizontal slider windows
Vision panel door with
standard lock or steel door
with dead bolt lock

OTHER

Optional restroom

* Photos are representational; actual products vary. Additional floor plans and specifications may vary from those shown and are subject to in-stock availability.

WILLSCOT

TM

SPACE SOLUTIONS | 800.782.1500 | WILLSCOT.COM

RIGHT FROM THE START



32' x 8' Mobile Office

Made with durable, high-quality materials that meet national and state building, electrical, mechanical and plumbing codes, our 32' x 8' mobile office trailer provides 224 sq. ft. of mobile office space.

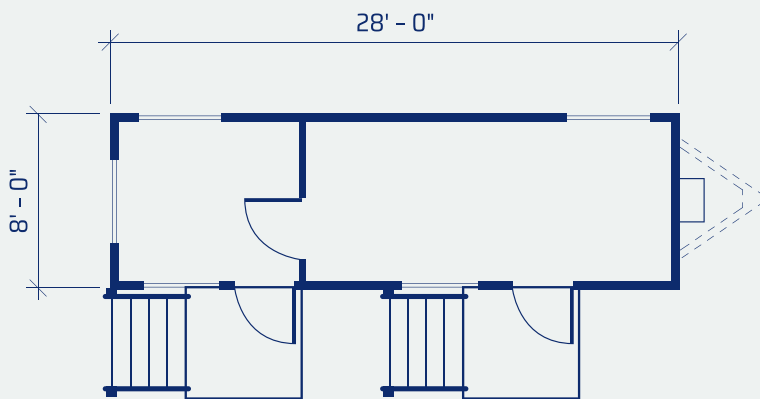

Complete Your Space

- Steps & Ramps
- Furniture & Appliances
- Technology
- Site Services
- Protection Plans

DIMENSIONS

32' Long (including hitch)
28' Box size
8' Wide
7' Ceiling height

EXTERIOR FINISH

Aluminum or wood siding
I-beam frame
Standard drip rail gutters

INTERIOR FINISH

Gypsum ceiling
Paneled walls
Vinyl tile floor

ELECTRIC

Flourescent ceiling lights
Breaker panel

HEATING/COOLING

Electric baseboard heat and
thru-wall AC unit or
combination heat/AC unit

WINDOWS / DOORS

Horizontal slider windows
(2) Vision panel doors with
standard locks or (2) steel
doors with dead bolt locks

OTHER

Optional restrooms

* Photos are representational; actual products vary. Additional floor plans and specifications may vary from those shown and are subject to in-stock availability

WILLSCOT

TM

SPACE SOLUTIONS | 800.782.1500 | WILLSCOT.COM

RIGHT FROM THE START



36' x 10' Mobile Office

Available with a wide-open floorplan or with one private office and a common area, our 36' x 10' mobile office trailer provides 320 sq. ft. of mobile office space.

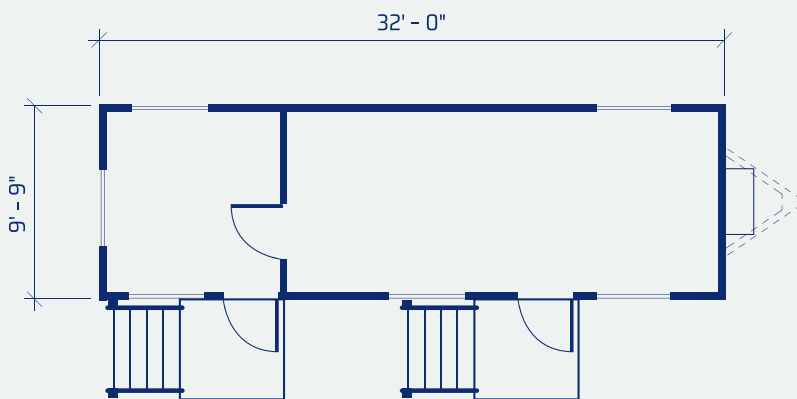

Complete Your Space

- Steps & Ramps
- Furniture & Appliances
- Technology
- Site Services
- Protection Plans

DIMENSIONS

36' Long (including hitch)
32' Box size
10' Wide
8' Ceiling height

EXTERIOR FINISH

Aluminum or wood siding
I-beam frame
Standard drip rail gutters

INTERIOR FINISH

Gypsum ceiling or T-grid
suspended ceiling
Paneled walls
Vinyl tile floor

ELECTRIC

Flourescent ceiling lights
Breaker panel

HEATING/COOLING

Electric baseboard heat
and thru-wall AC unit or
central HVAC

WINDOWS / DOORS

Horizontal slider windows
(2) Vision panel doors with
standard locks or (2) steel
doors with dead bolt locks

ADDITIONAL OPTIONS

Restrooms

OPTIONAL SERVICES

Holding tank
Water tank

* Photos are representational; actual products vary. Additional floor plans and specifications may vary from those shown and are subject to in-stock availability

WILLSCOT

SPACE SOLUTIONS | 800.782.1500 | WILLSCOT.COM

RIGHT FROM THE START



44' x 12'

Mobile Office

Our 44' x 12' job site trailer provides 480 sq. ft. of mobile office space and is made with durable, high-quality materials that meet national and state building, electrical, mechanical and plumbing codes.

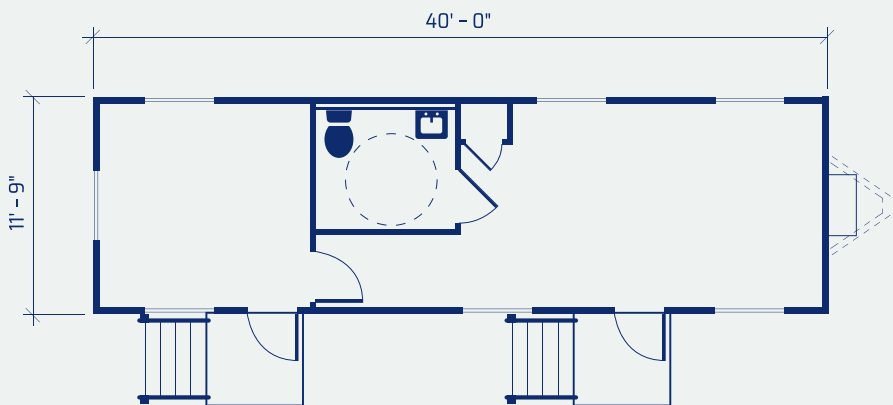

Complete Your Space

- Steps & Ramps
- Furniture & Appliances
- Technology
- Site Services
- Protection Plans

DIMENSIONS

44' Long (including hitch)
40' Box size
12' Wide
8' Ceiling height

EXTERIOR FINISH

Aluminum or wood siding
I-beam frame
Standard drip rail gutters

INTERIOR FINISH

Gypsum ceiling or T-grid suspended ceiling
Paneled walls
Vinyl tile floor

ELECTRIC

Flourescent ceiling lights
Breaker panel

HEATING/COOLING

Central HVAC or thru-wall AC

WINDOWS / DOORS

Horizontal slider windows
(2) Vision panel doors with standard locks or (2) steel doors with dead bolt locks

ADDITIONAL OPTIONS

Restrooms

OPTIONAL SERVICES

Holding tank
Water tank

* Photos are representational; actual products vary. Additional floor plans and specifications may vary from those shown and are subject to in-stock availability.

WILLSCOT

TM

SPACE SOLUTIONS | 800.782.1500 | WILLSCOT.COM

RIGHT FROM THE START



50' x 10' Mobile Office

Our 50' x 10' job site trailer provides 460 sq. ft. of mobile office space and is made with durable, high-quality materials that meet national and state building, electrical, mechanical and plumbing codes.

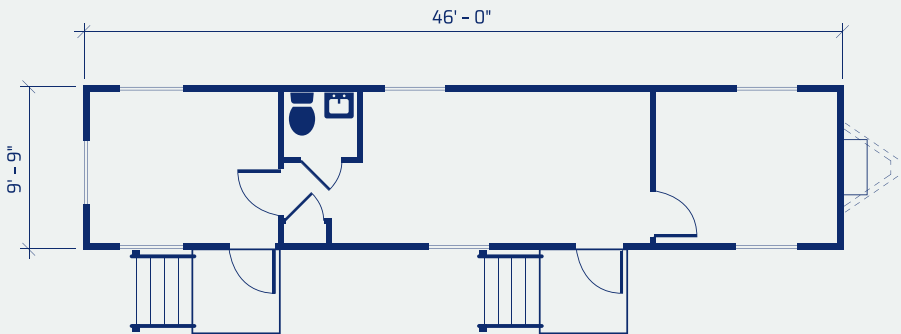

Complete Your Space

- Steps & Ramps
- Furniture & Appliances
- Technology
- Site Services
- Protection Plans

DIMENSIONS

50' Long (including hitch)
46' Box size
10' Wide
8' Ceiling height

EXTERIOR FINISH

Aluminum or wood siding
I-beam frame
Standard drip rail gutters

INTERIOR FINISH

Gypsum ceiling or T-grid
suspended ceiling
Paneled walls
Vinyl tile floor

ELECTRIC

Flourescent ceiling lights
Breaker panel

HEATING/COOLING

Central HVAC or thru-wall AC

WINDOWS / DOORS

Horizontal slider windows
(2) Vision panel doors with
standard locks or (2) steel
doors with dead bolt locks

ADDITIONAL OPTIONS

Restrooms

OPTIONAL SERVICES

Holding tank
Water tank

* Photos are representational; actual products vary. Additional floor plans and specifications may vary from those shown and are subject to in-stock availability.



RIGHT FROM THE START

50' x 12' Office Trailer

Our 50' x 12' job site trailer provides 552 sq. ft. of mobile office space and is made with durable, high-quality materials that meet national and state building, electrical, mechanical and plumbing codes.

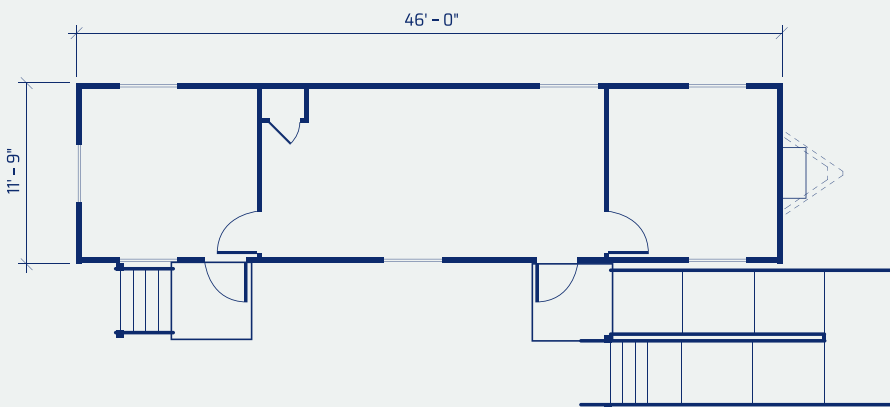

Customization

- Steps & Ramps
- Furniture & Appliances
- Technology
- Site Services
- Protection Plans

DIMENSIONS

50' Long (including hitch)
46' Box size
12' Wide
8' Ceiling height

EXTERIOR FINISH

Aluminum or wood siding
I-beam frame
Standard drip rail gutters

INTERIOR FINISH

Gypsum ceiling or T-grid
suspended ceiling
Paneled walls
Vinyl tile floor

ELECTRIC

Flourescent ceiling lights
Breaker panel

HEATING/COOLING

Electric baseboard heat and
thru-wall AC unit or
combination heat/AC unit

WINDOWS / DOORS

Horizontal slider windows
(2) Vision panel doors with
standard locks

OTHER

Optional restrooms

* Photos are representational; actual products vary. Additional floor plans and specifications may vary from those shown and are subject to in-stock availability.

WILLSCOT

TM

SPACE SOLUTIONS | 800.782.1500 | WILLSCOT.COM

RIGHT FROM THE START



60' x 12' Mobile Office

Our 60' x 12' job site trailer provides 672 sq. ft. of mobile office space and is made with durable, high-quality materials that meet national and state building, electrical, mechanical and plumbing codes.

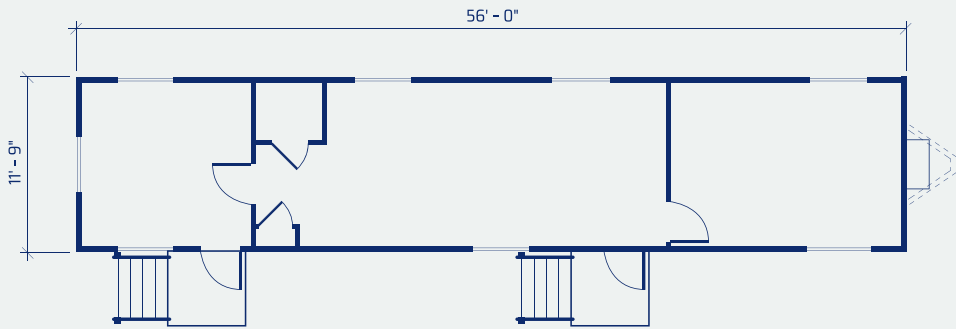

Complete Your Space

- Steps & Ramps
- Furniture & Appliances
- Technology
- Site Services
- Protection Plans

DIMENSIONS

60' Long (including hitch)
56' Box size
12' Wide
8' Ceiling height

EXTERIOR FINISH

Aluminum or wood siding
I-beam frame
Standard drip rail gutters

INTERIOR FINISH

Gypsum ceiling
Vinyl covered gypsum walls
Carpet or vinyl floors

ELECTRIC

Flourescent ceiling lights
Breaker panel

HEATING/COOLING

Central HVAC or thru-wall AC

WINDOWS / DOORS

Horizontal slider windows
Vision panel doors with
standard locks

ADDITIONAL OPTIONS

Restrooms

OPTIONAL SERVICES

Holding tank
Water tank

* Photos are representational; actual products vary. Additional floor plans and specifications may vary from those shown and are subject to in-stock availability.



ATTACHMENT B

Small, Women and Minority-owned Businesses (SWaM) Utilization Plan

Offeror Name: James Madison University Preparer Name: Will Scott

Date: 4/27

Is your firm a **Small Business Enterprise** certified by the Department of Small Business and Supplier Diversity (SBSD)? Yes No

If yes, certification number: _____ Certification date: _____

Is your firm a **Woman-owned Business Enterprise** certified by the Department of Small Business and Supplier Diversity (SBSD)? Yes No

If yes, certification number: _____ Certification date: _____

Is your firm a **Minority-Owned Business Enterprise** certified by the Department of Small Business and Supplier Diversity (SBSD)? Yes No

If yes, certification number: _____ Certification date: _____

Is your firm a **Micro Business** certified by the Department of Small Business and Supplier Diversity (SBSD)? Yes No

If yes, certification number: _____ Certification date: _____

Instructions: *Populate the table below to show your firm's plans for utilization of small, women-owned and minority-owned business enterprises in the performance of the contract. Describe plans to utilize SWaMs businesses as part of joint ventures, partnerships, subcontractors, suppliers, etc.*

Small Business: "Small business " means a business, independently owned or operated by one or more persons who are citizens of the United States or non-citizens who are in full compliance with United States immigration law, which, together with affiliates, has 250 or fewer employees, or average annual gross receipts of \$10 million or less averaged over the previous three years.

Woman-Owned Business Enterprise: A business concern which is at least 51 percent owned by one or more women who are U.S. citizens or legal resident aliens, or in the case of a corporation, partnership or limited liability company or other entity, at least 51 percent of the equity ownership interest in which is owned by one or more women, and whose management and daily business operations are controlled by one or more of such individuals. **For purposes of the SWaM Program, all certified women-owned businesses are also a small business enterprise.**

Minority-Owned Business Enterprise: A business concern which is at least 51 percent owned by one or more minorities or in the case of a corporation, partnership or limited liability company or other entity, at least 51 percent of the equity ownership interest in which is owned by one or more minorities and whose management and daily business operations are controlled by one or more of such individuals. **For purposes of the SWaM Program, all certified minority-owned businesses are also a small business enterprise.**

Micro Business is a certified Small Business under the SWaM Program and has no more than twenty-five (25) employees AND no more than \$3 million in average annual revenue over the three-year period prior to their certification.

All small, women, and minority owned businesses must be certified by the Commonwealth of Virginia Department of Small Business and Supplier Diversity (SBSD) to be counted in the SWaM program. Certification applications are available through SBSD at 800-223-0671 in Virginia, 804-786-6585 outside Virginia, or online at <http://www.sbsd.virginia.gov/> (Customer Service).

RETURN OF THIS PAGE IS REQUIRED

ATTACHMENT B (CNT'D)
Small, Women and Minority-owned Businesses (SWaM) Utilization Plan

Procurement Name and Number: DEM-1246 Date Form Completed: 4/27/26

Listing of Sub-Contractors, to include, Small, Woman Owned and Minority Owned Businesses for this Proposal and Subsequent Contract

Offeror / Proposer: Williscot Firm
 Address: 3120 Hollis Rd NE, Rankin VA Total MW/FW - 540,240.1230
 Contact Person/No. _____

Sub-Contractor's Name and Address	Contact Person & Phone Number	SBSD Certification Number	Services or Materials Provided	Total Subcontractor Contract Amount (to include change orders)	Total Dollars Paid Subcontractor to date (to be submitted with request for payment from JMU)
N/A	N/A	N/A	N/A	N/A	N/A

(Form shall be submitted with proposal and if awarded, a SWaM Sub-contractor Reporting Form shall be submitted to swamreporting@jmu.edu)

RETURN OF THIS PAGE IS REQUIRED



January 29, 2026

ADDENDUM NO.: One

TO ALL OFFERORS:

REFERENCE: Request for Proposal No: RFP #DKM - 1246
Dated: January 29, 2026
Commodity: *Modular Buildings and Storage Containers*
RFP Closing On: February 12, 2026

Question 1: Is it fair to categorize this solicitation as an IDIQ type procurement mechanism as opposed to a one-time transaction?

Answer: IDIQ is a term used by the Federal Government to describe a similar contract vehicle. JMU does not utilize IDIQs contracts. This RFP will result in a term contract that allows JMU to order goods and/or services as, needed, similar in practice to an IDIQ with awarded vendor(s) and set pricing. The RFP process allows the University to evaluate cost, quality of goods/services, methodology for providing the goods/services, and the experience of the offeror.

Question 2: Would a presentation of our GSA schedule of goods and services serve the purpose?

Answer: Offerors should return a proposal that comprehensively responds to all questions in section IV (Statement of Needs) to be considered a complete response. Offerors may include additional information for consideration at their discretion.

Question 3: Would JMU consider subcontractors being the sole contractor license holder or would the prime contractor have to be the sole contractor license holder?

Answer: The University will consider proposals submitted with the subcontractor as the contractor's license holder, provided they have valid documentation demonstrating that they are the sole license holder.

Question 4: Does the firm submitting the proposal need to have an office in Virginia?

Answer: For the duration of the contract, the prime contractor is not required to maintain an office in Virginia; However, it will be required that either the prime contractor or a valid subcontractor identified in the proposal maintains a Virginia address.

MSC 5720
752 Ott Street, Room 1042
Wine Price Building
Harrisonburg, VA 22807
Office of 540.568.3145 Phone
PROCUREMENT SERVICES 540.568.7935 Fax

Question 5: Are these buildings/containers a specific need for a current project or to be provided on an as-need basis?

Answer: These buildings/containers will be provided on an as-need basis during the length of the contract term.

Signify receipt of this addendum by initialing “*Addendum #1* _____” on the signature page of your proposal.

Sincerely,

Dylan Morris
Buyer Senior
Phone: (540-568-3002)



Request for Proposal

RFP# DKM-1246

Modular Buildings and Storage Containers

January 13, 2026



REQUEST FOR PROPOSAL
RFP# DKM-1246

Issue Date: January 13, 2026
Title: Modular Buildings and Storage Containers
Issuing Agency: Commonwealth of Virginia
James Madison University
Procurement Services MSC 5720
752 Ott Street, Wine Price Building
First Floor, Suite 1023
Harrisonburg, VA 22807

Period of Contract: From Date of Award Through One Year (Renewable)

Sealed Proposals Will Be Received Until 2:00 PM on February 12, 2026 for Furnishing The Services Described Herein. (See Special Terms & Conditions “D. Late Proposals”)

SEALED PROPOSALS MAY BE MAILED, EXPRESS MAILED, SUBMITTED IN eVA, OR HAND DELIVERED DIRECTLY TO THE ISSUING AGENCY SHOWN ABOVE.

All Inquiries For Information And Clarification Should Be Directed To: Dylan Morris, Buyer Senior, Procurement Services, morrisdk@jmu.edu; 540-568-3002; (Fax) 540-568-7935 before end of day on February 5th, 2026.

NOTE: THE SIGNED PROPOSAL AND ALL ATTACHMENTS SHALL BE RETURNED.

In compliance with this Request for Proposal and to all the conditions imposed herein, the undersigned offers and agrees to furnish the goods/services in accordance with the attached signed proposal or as mutually agreed upon by subsequent negotiation.

Name and Address of Firm: _____
By: _____
(Signature)
Name: _____
(Please Print)
Date: _____ Title: _____
Web Address: _____ Phone: _____
Email: _____ Fax #: _____

ACKNOWLEDGE RECEIPT OF ADDENDUM: #1 _____ #2 _____ #3 _____ #4 _____ #5 _____ (please initial)

SMALL, WOMAN OR MINORITY OWNED BUSINESS:
 YES; NO; *IF YES* ⇒⇒ SMALL; WOMAN; MINORITY ***IF MINORITY:*** AA; HA; AsA; NW; Micro

Note: This public body does not discriminate against faith-based organizations in accordance with the Code of Virginia, § 2.2-4343.1 or against an offeror because of race, religion, color, sex, national origin, age, disability, or any other basis prohibited by state law relating to discrimination in employment.

REQUEST FOR PROPOSAL

RFP # DKM-1246

TABLE OF CONTENTS

I.	PURPOSE	Page	1
II.	BACKGROUND	Page	1
III.	SMALL, WOMAN-OWNED, AND MINORITY PARTICIPATION	Page	1
IV.	STATEMENT OF NEEDS	Page	2-3
V.	PROPOSAL PREPARATION AND SUBMISSION	Page	4-7
VI.	EVALUATION AND AWARD CRITERIA	Page	7-8
VII.	GENERAL TERMS AND CONDITIONS	Page	8-15
VIII.	SPECIAL TERMS AND CONDITIONS	Page	15-21
IX.	METHOD OF PAYMENT	Page	21
X.	PRICING SCHEDULE	Page	21-22
XI.	ATTACHMENTS	Page	22-30
	A. Offeror Data Sheet		
	B. SWaM Utilization Plan		
	C. Sample of Standard Contract		
	D. Zone Map		
	E. VHEPC PAC Agreement		
	F. SWaM Standard Reporting Template		

I. PURPOSE

The purpose of this Request for Proposal (RFP) is to solicit sealed proposals from qualified sources to enter into a contract to provide modular building systems and shipping container solutions for James Madison University (JMU), an agency of the Commonwealth of Virginia and on behalf of the Virginia Higher Education Procurement Consortium (VHEPC). Initial contract shall be for one (1) year with an option to renew for four (4) additional one-year periods.

II. BACKGROUND

James Madison University (JMU) is a comprehensive public institution in Harrisonburg, Virginia with an enrollment of approximately 22,000 students and approximately 4,000 faculty and staff. There are over 600 individual departments on campus that support seven (7) academic divisions. The University offers over 120 majors, minors, and concentrations. Further information about the University can be found at the following website: www.jmu.edu.

VHEPC membership includes 13 of Virginia's senior public higher education institutions, the Virginia Association of State College and University Purchasing Professionals (VASCUPP) Board of Directors, and the Virginia Community College System, which represents 23 schools across the state. The mission of VHEPC, by using the collective buying power of its members, is to seek opportunities, leverage suppliers, and recommend courses of action in order to further strategic sourcing initiatives. This RFP is one of the strategic sourcing initiatives. The goal of this RFP and the resulting agreements is to provide an opportunity to reduce costs, minimize administrative burden, and to ensure regulatory and policy compliance for VHEPC and VHEPC Members.

VASCUPP Background:

The mission of the Virginia Association of State College and University Purchasing Professionals (VASCUPP) is:

- to recognize and effectively use the common procurement principles, knowledge, experience, challenges, support and resources of all decentralized higher education member institutions;
- to be a united group with common goals of addressing the complexities of the Commonwealth of Virginia procurement processes;
- enhance the ability of each individual member institution to effectively provide efficient and responsive customer service in facilitating the purchase of goods and services for their Institution; and
- to support diversified vendor advocacy to enhance the capability of each member institution in seeking open competition for the highest valued products and services.

More information about each VASCUPP member university can be located at the following website: <https://vascupp.org/>

III. SMALL, WOMAN-OWNED AND MINORITY PARTICIPATION

It is the policy of the Commonwealth of Virginia to contribute to the establishment, preservation, and strengthening of small businesses and businesses owned by women and minorities, and to encourage their participation in State procurement activities. The Commonwealth encourages contractors to provide for the participation of small businesses and businesses owned by women and minorities through partnerships, joint ventures, subcontracts, and other contractual opportunities. Attachment B contains information on reporting spend data with subcontractors.

IV. STATEMENT OF NEEDS

James Madison University seeks to find contractors with expertise in both sales and rentals of Modular Building Systems and Storage/Shipping Containers. Vendors may provide one or both of the requested products.

Modular Building Systems

- A. James Madison University seeks to contract for the services of modular building vendor(s) with expertise in all phases of the work associated with the design modification, construction, site preparation, transportation and installation of a turn-key modular building. The work may include, but is not limited to, modular building construction, pre-construction design modification, site design and preparation, permitting, modular transportation, installation, tenant improvement and commissioning of the modular building.
- B. Contractor shall have offices located within the State of Virginia.
- C. Contractor shall have a Virginia Class A Contractor's License is required. Include a copy of Virginia Class A License within proposal.
- D. Contractor shall prove ability to be bonded. Include a letter from insurance company showing proof of bonding ability.
- E. Contractor shall have an in-house project manager. Project manager shall have a minimum of 10-30 hours of OSHA training.
- F. All subcontractors must be approved by the Agency's project manager.
- G. Contractor shall warrant the work, and supply written verification of warranty to the project manager. Warranty requirements shall be provided by the Agency on a per project basis for consideration in each proposal.
- H. Contractor shall comply with all applicable federal, state, local and Agency regulations in the performance of this work.
- I. Contractor shall have sufficient resources to be able to work multiple projects at the same time.
- J. Contractor shall provide Agency with all project design documents to include foundation and site work when required by the Agency. Agency will submit to DEB for review. Contractor shall make requested changes as many times as required to obtain DEB approval. Agencies that are not required to go through DEB, documents shall be reviewed by the proper authorities having jurisdiction.
- K. Contractor shall show proof of experience in working with DEB.

Storage/Shipping Containers

- A. The contractor(s) shall provide all labor supervision, equipment, tools, parts, and materials, as necessary, to Agency or Authorized Representative for moving or storage services as outlined below.

- B. Contractor shall be able to meet the needs for any and all storage containers, not limited to stationary and portable storage.
- C. Provide moving and/or on-site storage of goods on interstate, intrastate, or local transportation basis and in-transit storage.
- D. Contractor's employees shall conduct themselves in a professional manner and be respectful to all Agency personnel or associates they interact with.
- E. Contractor shall arrive with any and all of the proper equipment required to perform required services.
- F. Contractor shall provide information and services to Agency or Authorize Agency representative, including but not limited to packing, moving, in-transit storage, on-site storage, unpacking, insurance of any stored or transported material, and discarding of any and all debris.
- G. Contractor shall provide an estimate to the Agency prior to beginning services for approval. If approved the Agency will issue an eVA purchase order to Contractor.
- H. Contractor shall provide or assist in arranging supplemental services relating to the move or storage of goods.
- I. Contractor shall have current permits and licenses required to provide any and all services described.

DESCRIBE STATEMENTS: *Be sure to address the following statements within proposal.*

1. Describe Contractor's ability to provide services for all phases of modular construction. Phases include, but not limited to, financing (lease, rent or purchase), pre-construction/site work, permitting, installation, building design, construction, tenant improvement, and commissioning of modular buildings.
2. Describe Contractor's ability to service any location within the State of Virginia. If your proposal is limited by geography, please identify the particular regions you propose to provide goods and services in.
3. Fully describe the qualifications, capabilities, and experience of your firm, in providing the requested services, to include the size of the company, and number of employees.
4. Provide an organizational chart indicating each individual and their position that will be associated with this contract. Also indicate each representative's name and contact information that will be responsible for each region in the State of Virginia.
5. Provide a statement that indicates whether or not your firm has been subject to OSHA inspections by State and/or Federal agencies, and the results of these inspections, including citations, if any.
6. Provide information regarding any contract than an institution, agency, or company that chose not to renew with your firm in the last five years, including the reason the contract was not renewed.

V. PROPOSAL PREPARATION AND SUBMISSION

A. GENERAL INSTRUCTIONS

To ensure timely and adequate consideration of your proposal, offerors are to limit all contact, whether verbal or written, pertaining to this RFP to the James Madison University Procurement Office for the duration of this Proposal process. Failure to do so may jeopardize further consideration of Offeror's proposal.

ELECTRONIC OR PAPER SUBMISSIONS MAY BE ACCEPTED FOR THIS PROPOSAL. INSTRUCTIONS BELOW FOR OFFEROR'S CHOSEN METHOD (A. ELECTRONIC SUBMISSION or B. PAPER RESPONSE).

1. RFP Response: In order to be considered for selection, the **Offeror shall submit a complete response to this RFP**; and shall submit to the issuing Purchasing Agency:

a. **ELECTRONIC SUBMISSION:**

- i. ELECTRONIC RESPONSES SUBMITTED THROUGH eVA WILL BE ACCEPTED. **Emailed responses will not be accepted.** Please see below, "eVA Procurement Website and Registration" for additional information on registration. It is the responsibility of the Supplier to ensure their proposal and all required documentation is properly completed, readable, and uploaded to eVA. Suppliers should allow sufficient time to account for any technical difficulties they may encounter during online submission or uploading of the documents. In the event of any technical difficulties, Suppliers shall contact the eVA Customer Care Center at 1-866-289-7367 or via email at eVACustomerCare@DGS.virginia.gov.
- ii. eVA Procurement Website and Registration The Commonwealth's procurement portal, eVA, located at <http://www.eva.virginia.gov>, provides information about Commonwealth solicitations and awards. Suppliers shall be registered in eVA in order submit a proposal to this RFP. To register with eVA, select "Register Now" on the eVA website homepage, <http://www.eva.virginia.gov>. For registration instructions and assistance, as well as instructions on how to submit proposals and accept orders please select "I Sell to Virginia". Suppliers are encouraged to check this site on a regular basis and, in particular, prior to submission of proposals to identify any amendments to the RFP that may have been issued.
- iii. Electronic Responses submitted through eVA shall be in WORD format or searchable PDF of the entire proposal, INCLUDING ALL ATTACHMENTS. PDFs must be submitted in an unlocked format. Any proprietary information should be clearly marked in accordance with Section V.4.f. below.

b. **PAPER SUBMISSIONS:**

- i. **One (1) original and one (1) copy** of the entire proposal, INCLUDING ALL ATTACHMENTS. Any proprietary information should be clearly marked in accordance with V.4.e. below.

- ii. **One (1) electronic copy in WORD format or searchable PDF** (*CD or flash drive*) of the entire proposal, **INCLUDING ALL ATTACHMENTS**. Any proprietary information should be clearly marked in accordance with Section V.4.f. below.
 - iii. Each copy of the proposal should be bound or contained in a single volume where practical. All documentation submitted with the proposal should be contained in that single volume.
 - iv. See additional information in Section VIII.C, *IDENIFICATION OF PROPSAL ENVELOPE*.
2. Should the proposal contain **proprietary information, provide one (1) redacted copy of the proposal** and all attachments with **proprietary portions removed or blacked out**. This copy should be clearly marked "*Redacted Copy*" on the front cover. The classification of an entire proposal document, line-item prices, and/or total proposal prices as proprietary or trade secrets is not acceptable. JMU shall not be responsible for the Contractor's failure to exclude proprietary information from this redacted copy.

No other distribution of the proposal shall be made by the Offeror.

3. The version of the solicitation issued by JMU Procurement Services, as amended by an addenda, is the mandatory controlling version of the document. Any modification of, or additions to, the solicitation by the Offeror shall not modify the official version of the solicitation issued by JMU Procurement services unless accepted in writing by the University. Such modifications or additions to the solicitation by the Offeror may be cause for rejection of the proposal; however, JMU reserves the right to decide, on a case-by-case basis in its sole discretion, whether to reject such a proposal. If the modification or additions are not identified until after the award of the contract, the controlling version of the solicitation document shall still be the official state form issued by Procurement Services.
4. Proposal Preparation
- a. Proposals shall be signed by an authorized representative of the Offeror. All information requested should be submitted. Failure to submit all information requested may result in the purchasing agency requiring prompt submissions of missing information and/or giving a lowered evaluation of the proposal. Proposals which are substantially incomplete or lack key information may be rejected by the purchasing agency. Mandatory requirements are those required by law or regulation or are such that they cannot be waived and are not subject to negotiation.
 - b. Proposals shall be prepared simply and economically, providing a straightforward, concise description of capabilities to satisfy the requirements of the RFP. Emphasis should be placed on completeness and clarity of content.
 - c. Proposals should be organized in the order in which the requirements are presented in the RFP. All pages of the proposal should be numbered. Each paragraph in the proposal should reference the paragraph number of the corresponding section of the RFP. It is also helpful to cite the paragraph number, sub letter, and repeat the text of the requirement as it appears in the RFP. If a response covers more than one page, the paragraph number and sub letter should be repeated at the top of the next page. The

proposal should contain a table of contents which cross references the RFP requirements. Information which the offeror desires to present that does not fall within any of the requirements of the RFP should be inserted at the appropriate place or be attached at the end of the proposal and designated as additional material. Proposals that are not organized in this manner risk elimination from consideration if the evaluators are unable to find where the RFP requirements are specifically addressed.

- d. As used in this RFP, the terms “must”, “shall”, “should” and “may” identify the criticality of requirements. “Must” and “shall” identify requirements whose absence will have a major negative impact on the suitability of the proposed solution. Items labeled as “should” or “may” are highly desirable, although their absence will not have a large impact and would be useful, but are not necessary. Depending on the overall response to the RFP, some individual “must” and “shall” items may not be fully satisfied, but it is the intent to satisfy most, if not all, “must” and “shall” requirements. The inability of an offeror to satisfy a “must” or “shall” requirement does not automatically remove that offeror from consideration; however, it may seriously affect the overall rating of the offeror’ proposal.
 - e. Each copy of the proposal should be bound or contained in a single volume where practical. All documentation submitted with the proposal should be contained in that single volume.
 - f. Ownership of all data, materials and documentation originated and prepared for the State pursuant to the RFP shall belong exclusively to the State and be subject to public inspection in accordance with the Virginia Freedom of Information Act. Trade secrets or proprietary information submitted by the offeror shall not be subject to public disclosure under the Virginia Freedom of Information Act; however, the offeror must invoke the protection of Section 2.2-4342F of the Code of Virginia, in writing, either before or at the time the data is submitted. **The written notice must specifically identify the data or materials to be protected and state the reasons why protection is necessary. The proprietary or trade secret materials submitted must be identified by some distinct method such as highlighting or underlining and must indicate only the specific words, figures, or paragraphs that constitute trade secret or proprietary information. The classification of an entire proposal document, line-item prices and/or total proposal prices as proprietary or trade secrets is not acceptable. Marking an entire proposal as confidential or attempts to prevent disclosure of pricing information by designating it as confidential, proprietary or trade secret will be ignored.**
5. Oral Presentation: Offerors who submit a proposal in response to this RFP may be required to give an oral presentation of their proposal to James Madison University. This provides an opportunity for the Offeror to clarify or elaborate on the proposal. This is a fact-finding and explanation session only and does not include negotiation. James Madison University will schedule the time and location of these presentations. Oral presentations are an option of the University and may or may not be conducted. Therefore, proposals should be complete.

B. SPECIFIC PROPOSAL INSTRUCTIONS

Proposals should be as thorough and detailed as possible so that James Madison University may properly evaluate your capabilities to provide the required services. Offerors are required to submit the following items as a complete proposal:

1. Return RFP cover sheet and all addenda acknowledgements, if any, signed and filled out as required. (Electronic signature shall be accepted, i.e. Adobe Sign, DocuSign, etc.)
2. Plan and methodology for providing the goods/services as described in Section IV. Statement of Needs of this Request for Proposal.
3. A written narrative statement to include, but not be limited to, the expertise, qualifications, and experience of the firm and resumes of specific personnel to be assigned to perform the work.
4. Offeror Data Sheet, included as *Attachment A* to this RFP.
5. Small Business Subcontracting Plan, included as *Attachment B* to this RFP. Offeror shall provide a Small Business Subcontracting plan which summarizes the planned utilization of Department of Small Business and Supplier Diversity (SBSD)-certified small businesses which include businesses owned by women and minorities, when they have received Department of Small Business and Supplier Diversity (SBSD) small business certification, under the contract to be awarded as a result of this solicitation. This is a requirement for all prime contracts in excess of \$100,000 unless no subcontracting opportunities exist.
6. Identify the amount of sales your company had during the last twelve months with each VASCUPP Member Institution. A list of VASCUPP Members can be found at: www.VASCUPP.org.
7. Proposed Cost. See Section X. Pricing Schedule of this Request for Proposal.

VI. EVALUATION AND AWARD CRITERIA

A. EVALUATION CRITERIA

Proposals shall be evaluated by James Madison University using the following criteria:

	<u>Points</u>
1. Quality of products/services offered and suitability for intended purposes	25
2. Qualifications and experience of Offeror in providing the goods/services	25
3. Specific plans or methodology to be used to perform the services	25
4. Participation of Small, Women-Owned, & Minority (SWaM) Businesses	10
5. Cost	<u>15</u>
	100

AWARD TO MULTIPLE OFFERORS: Selection shall be made of two or more offerors deemed to be fully qualified and best suited among those submitting proposals on the basis of the evaluation factors included in the Request for Proposals, including price, if so stated in the Request for Proposals. Negotiations shall be conducted with the offerors so selected. Price shall be considered, but need not be the sole determining factor. After negotiations have been conducted with each offeror so selected, the agency shall select the offeror which, in its opinion,

has made the best proposal, and shall award the contract to that offeror. The Commonwealth reserves the right to make multiple awards as a result of this solicitation. The Commonwealth may cancel this Request for Proposals or reject proposals at any time prior to an award, and is not required to furnish a statement of the reasons why a particular proposal was not deemed to be the most advantageous. Should the Commonwealth determine in writing and in its sole discretion that only one offeror is fully qualified, or that one offeror is clearly more highly qualified than the others under consideration, a contract may be negotiated and awarded to that offeror. The award document will be a contract incorporating by reference all the requirements, terms and conditions of the solicitation and the contractor's proposal as negotiated.

VII. GENERAL TERMS AND CONDITIONS

- A. PURCHASING MANUAL: This solicitation is subject to the provisions of the Commonwealth of Virginia's Purchasing Manual for Institutions of Higher Education and Their Vendors and any revisions thereto, which are hereby incorporated into this contract in their entirety. A copy of the manual is available for review at the purchasing office. In addition, the manual may be accessed electronically at <http://www.jmu.edu/procurement> or a copy can be obtained by calling Procurement Services at (540) 568-3145.
- B. APPLICABLE LAWS AND COURTS: This solicitation and any resulting contract shall be governed in all respects by the laws of the Commonwealth of Virginia and any litigation with respect thereto shall be brought in the courts of the Commonwealth. The Contractor shall comply with applicable federal, state and local laws and regulations.
- C. ANTI-DISCRIMINATION: By submitting their proposals, offerors certify to the Commonwealth that they will conform to the provisions of the Federal Civil Rights Act of 1964, as amended, as well as the Virginia Fair Employment Contracting Act of 1975, as amended, where applicable, the Virginians With Disabilities Act, the Americans With Disabilities Act and §10 of the Rules Governing Procurement, Chapter 2, Exhibit J, Attachment 1 (available for review at <http://www.jmu.edu/procurement>). If the award is made to a faith-based organization, the organization shall not discriminate against any recipient of goods, services, or disbursements made pursuant to the contract on the basis of the recipient's religion, religious belief, refusal to participate in a religious practice, or on the basis of race, age, color, gender, sexual orientation, gender identity, or national origin and shall be subject to the same rules as other organizations that contract with public bodies to account for the use of the funds provided; however, if the faith-based organization segregates public funds into separate accounts, only the accounts and programs funded with public funds shall be subject to audit by the public body. (*§6 of the Rules Governing Procurement*).

In every contract over \$10,000 the provisions in 1. and 2. below apply:

1. During the performance of this contract, the contractor agrees as follows:
 - a. The contractor will not discriminate against any employee or applicant for employment because of race, religion, color, sex, sexual orientation, gender identity, national origin, age, disability, or any other basis prohibited by state law relating to discrimination in employment, except where there is a bona fide occupational qualification reasonably necessary to the normal operation of the contractor. The contractor agrees to post in conspicuous places, available to employees and applicants for employment, notices setting forth the provisions of this nondiscrimination clause.

- b. The contractor, in all solicitations or advertisements for employees placed by or on behalf of the contractor, will state that such contractor is an equal opportunity employer.
 - c. Notices, advertisements, and solicitations placed in accordance with federal law, rule, or regulation shall be deemed sufficient for the purpose of meeting these requirements.
 - 2. The contractor will include the provisions of 1. above in every subcontract or purchase order over \$10,000, so that the provisions will be binding upon each subcontractor or vendor.
- D. ETHICS IN PUBLIC CONTRACTING: By submitting their proposals, offerors certify that their proposals are made without collusion or fraud and that they have not offered or received any kickbacks or inducements from any other offeror, supplier, manufacturer or subcontractor in connection with their proposal, and that they have not conferred on any public employee having official responsibility for this procurement transaction any payment, loan, subscription, advance, deposit of money, services or anything of more than nominal value, present or promised, unless consideration of substantially equal or greater value was exchanged.
- E. IMMIGRATION REFORM AND CONTROL ACT OF 1986: By entering into a written contract with the Commonwealth of Virginia, the Contractor certifies that the Contractor does not, and shall not during the performance of the contract for goods and services in the Commonwealth, knowingly employ an unauthorized alien as defined in the federal Immigration Reform and Control Act of 1986.
- F. DEBARMENT STATUS: By submitting their proposals, offerors certify that they are not currently debarred by the Commonwealth of Virginia from submitting proposals on contracts for the type of goods and/or services covered by this solicitation, nor are they an agent of any person or entity that is currently so debarred.
- G. ANTITRUST: By entering into a contract, the contractor conveys, sells, assigns, and transfers to the Commonwealth of Virginia all rights, title and interest in and to all causes of action it may now have or hereafter acquire under the antitrust laws of the United States and the Commonwealth of Virginia, relating to the particular goods or services purchased or acquired by the Commonwealth of Virginia under said contract.
- H. MANDATORY USE OF STATE FORM AND TERMS AND CONDITIONS RFPs: Failure to submit a proposal on the official state form provided for that purpose may be a cause for rejection of the proposal. Modification of or additions to the General Terms and Conditions of the solicitation may be cause for rejection of the proposal; however, the Commonwealth reserves the right to decide, on a case by case basis, in its sole discretion, whether to reject such a proposal.
- I. CLARIFICATION OF TERMS: If any prospective offeror has questions about the specifications or other solicitation documents, the prospective offeror should contact the buyer whose name appears on the face of the solicitation no later than five working days before the due date. Any revisions to the solicitation will be made only by addendum issued by the buyer.
- J. PAYMENT:
 - 1. To Prime Contractor:

- a. Invoices for items ordered, delivered and accepted shall be submitted by the contractor directly to the payment address shown on the purchase order/contract. All invoices shall show the state contract number and/or purchase order number; social security number (for individual contractors) or the federal employer identification number (for proprietorships, partnerships, and corporations).
- b. Any payment terms requiring payment in less than 30 days will be regarded as requiring payment 30 days after invoice or delivery, whichever occurs last. This shall not affect offers of discounts for payment in less than 30 days, however.
- c. All goods or services provided under this contract or purchase order, that are to be paid for with public funds, shall be billed by the contractor at the contract price, regardless of which public agency is being billed.
- d. The following shall be deemed to be the date of payment: the date of postmark in all cases where payment is made by mail, or the date of offset when offset proceedings have been instituted as authorized under the Virginia Debt Collection Act.
- e. Unreasonable Charges. Under certain emergency procurements and for most time and material purchases, final job costs cannot be accurately determined at the time orders are placed. In such cases, contractors should be put on notice that final payment in full is contingent on a determination of reasonableness with respect to all invoiced charges. Charges which appear to be unreasonable will be researched and challenged, and that portion of the invoice held in abeyance until a settlement can be reached. Upon determining that invoiced charges are not reasonable, the Commonwealth shall promptly notify the contractor, in writing, as to those charges which it considers unreasonable and the basis for the determination. A contractor may not institute legal action unless a settlement cannot be reached within thirty (30) days of notification. The provisions of this section do not relieve an agency of its prompt payment obligations with respect to those charges which are not in dispute (*Rules Governing Procurement, Chapter 2, Exhibit J, Attachment 1 § 53; available for review at <http://www.jmu.edu/procurement>*).

2. To Subcontractors:

- a. A contractor awarded a contract under this solicitation is hereby obligated:
 - (1) To pay the subcontractor(s) within seven (7) days of the contractor's receipt of payment from the Commonwealth for the proportionate share of the payment received for work performed by the subcontractor(s) under the contract; or
 - (2) To notify the agency and the subcontractors, in writing, of the contractor's intention to withhold payment and the reason.
- b. The contractor is obligated to pay the subcontractor(s) interest at the rate of one percent per month (unless otherwise provided under the terms of the contract) on all amounts owed by the contractor that remain unpaid seven (7) days following receipt of payment from the Commonwealth, except for amounts withheld as stated in (2) above. The date of mailing of any payment by U. S. Mail is deemed to be payment to the addressee.

These provisions apply to each sub-tier contractor performing under the primary contract. A contractor's obligation to pay an interest charge to a subcontractor may not be construed to be an obligation of the Commonwealth.

3. Each prime contractor who wins an award in which provision of a SWAM procurement plan is a condition to the award, shall deliver to the contracting agency or institution, on or before request for final payment, evidence and certification of compliance (subject only to insubstantial shortfalls and to shortfalls arising from subcontractor default) with the SWAM procurement plan. Final payment under the contract in question may be withheld until such certification is delivered and, if necessary, confirmed by the agency or institution, or other appropriate penalties may be assessed in lieu of withholding such payment.
 4. The Commonwealth of Virginia encourages contractors and subcontractors to accept electronic and credit card payments.
- K. PRECEDENCE OF TERMS: Paragraphs A through J of these General Terms and Conditions and the Commonwealth of Virginia Purchasing Manual for Institutions of Higher Education and their Vendors, shall apply in all instances. In the event there is a conflict between any of the other General Terms and Conditions and any Special Terms and Conditions in this solicitation, the Special Terms and Conditions shall apply.
- L. QUALIFICATIONS OF OFFERORS: The Commonwealth may make such reasonable investigations as deemed proper and necessary to determine the ability of the offeror to perform the services/furnish the goods and the offeror shall furnish to the Commonwealth all such information and data for this purpose as may be requested. The Commonwealth reserves the right to inspect offeror's physical facilities prior to award to satisfy questions regarding the offeror's capabilities. The Commonwealth further reserves the right to reject any proposal if the evidence submitted by, or investigations of, such offeror fails to satisfy the Commonwealth that such offeror is properly qualified to carry out the obligations of the contract and to provide the services and/or furnish the goods contemplated therein.
- M. TESTING AND INSPECTION: The Commonwealth reserves the right to conduct any test/inspection it may deem advisable to assure goods and services conform to the specifications.
- N. ASSIGNMENT OF CONTRACT: A contract shall not be assignable by the contractor in whole or in part without the written consent of the Commonwealth.
- O. CHANGES TO THE CONTRACT: Changes can be made to the contract in any of the following ways:
1. The parties may agree in writing to modify the scope of the contract. An increase or decrease in the price of the contract resulting from such modification shall be agreed to by the parties as a part of their written agreement to modify the scope of the contract.
 2. The Purchasing Agency may order changes within the general scope of the contract at any time by written notice to the contractor. Changes within the scope of the contract include, but are not limited to, things such as services to be performed, the method of packing or shipment, and the place of delivery or installation. The contractor shall comply with the notice upon receipt. The contractor shall be compensated for any additional costs incurred as the result of such order and shall give the Purchasing Agency a credit for any savings. Said compensation shall be determined by one of the following methods:

- a. By mutual agreement between the parties in writing; or
 - b. By agreeing upon a unit price or using a unit price set forth in the contract, if the work to be done can be expressed in units, and the contractor accounts for the number of units of work performed, subject to the Purchasing Agency's right to audit the contractor's records and/or to determine the correct number of units independently; or
 - c. By ordering the contractor to proceed with the work and keep a record of all costs incurred and savings realized. A markup for overhead and profit may be allowed if provided by the contract. The same markup shall be used for determining a decrease in price as the result of savings realized. The contractor shall present the Purchasing Agency with all vouchers and records of expenses incurred and savings realized. The Purchasing Agency shall have the right to audit the records of the contractor as it deems necessary to determine costs or savings. Any claim for an adjustment in price under this provision must be asserted by written notice to the Purchasing Agency within thirty (30) days from the date of receipt of the written order from the Purchasing Agency. If the parties fail to agree on an amount of adjustment, the question of an increase or decrease in the contract price or time for performance shall be resolved in accordance with the procedures for resolving disputes provided by the Disputes Clause of this contract or, if there is none, in accordance with the disputes provisions of the Commonwealth of Virginia Purchasing Manual for Institutions of Higher Education and their Vendors. Neither the existence of a claim nor a dispute resolution process, litigation or any other provision of this contract shall excuse the contractor from promptly complying with the changes ordered by the Purchasing Agency or with the performance of the contract generally.
- P. DEFAULT: In case of failure to deliver goods or services in accordance with the contract terms and conditions, the Commonwealth, after due oral or written notice, may procure them from other sources and hold the contractor responsible for any resulting additional purchase and administrative costs. This remedy shall be in addition to any other remedies which the Commonwealth may have.
- Q. INSURANCE: By signing and submitting a proposal under this solicitation, the offeror certifies that if awarded the contract, it will have the following insurance coverage at the time the contract is awarded. For construction contracts, if any subcontractors are involved, the subcontractor will have workers' compensation insurance in accordance with § 25 of the Rules Governing Procurement – Chapter 2, Exhibit J, Attachment 1, and 65.2-800 et. Seq. of the Code of Virginia (available for review at <http://www.jmu.edu/procurement>) The offeror further certifies that the contractor and any subcontractors will maintain these insurance coverage during the entire term of the contract and that all insurance coverage will be provided by insurance companies authorized to sell insurance in Virginia by the Virginia State Corporation Commission.

MINIMUM INSURANCE COVERAGES AND LIMITS REQUIRED FOR MOST CONTRACTS:

1. **Workers' Compensation:** Statutory requirements and benefits. Coverage is compulsory for employers of three or more employees, to include the employer. Contractors who fail to notify the Commonwealth of increases in the number of employees that change their workers' compensation requirement under the Code of Virginia during the course of the contract shall be in noncompliance with the contract.
2. **Employer's Liability:** \$100,000

3. Commercial General Liability: \$1,000,000 per occurrence and \$2,000,000 in the aggregate. Commercial General Liability is to include bodily injury and property damage, personal injury and advertising injury, products and completed operations coverage. The Commonwealth of Virginia must be named as an additional insured and so endorsed on the policy.
 4. Automobile Liability: \$1,000,000 combined single limit. *(Required only if a motor vehicle not owned by the Commonwealth is to be used in the contract. Contractor must assure that the required coverage is maintained by the Contractor (or third party owner of such motor vehicle.)*
- R. ANNOUNCEMENT OF AWARD: Upon the award or the announcement of the decision to award a contract over \$100,000, as a result of this solicitation, the purchasing agency will publicly post such notice on the DGS/DPS eVA web site (www.eva.virginia.gov) for a minimum of 10 days.
- S. DRUG-FREE WORKPLACE: During the performance of this contract, the contractor agrees to (i) provide a drug-free workplace for the contractor's employees; (ii) post in conspicuous places, available to employees and applicants for employment, a statement notifying employees that the unlawful manufacture, sale, distribution, dispensation, possession, or use of a controlled substance or marijuana is prohibited in the contractor's workplace and specifying the actions that will be taken against employees for violations of such prohibition; (iii) state in all solicitations or advertisements for employees placed by or on behalf of the contractor that the contractor maintains a drug-free workplace; and (iv) include the provisions of the foregoing clauses in every subcontract or purchase order of over \$10,000, so that the provisions will be binding upon each subcontractor or vendor.
- For the purposes of this section, "drug-free workplace" means a site for the performance of work done in connection with a specific contract awarded to a contractor, the employees of whom are prohibited from engaging in the unlawful manufacture, sale, distribution, dispensation, possession or use of any controlled substance or marijuana during the performance of the contract.
- T. NONDISCRIMINATION OF CONTRACTORS: An offeror, or contractor shall not be discriminated against in the solicitation or award of this contract because of race, religion, color, sex, sexual orientation, gender identity, national origin, age, disability, faith-based organizational status, any other basis prohibited by state law relating to discrimination in employment or because the offeror employs ex-offenders unless the state agency, department or institution has made a written determination that employing ex-offenders on the specific contract is not in its best interest. If the award of this contract is made to a faith-based organization and an individual, who applies for or receives goods, services, or disbursements provided pursuant to this contract objects to the religious character of the faith-based organization from which the individual receives or would receive the goods, services, or disbursements, the public body shall offer the individual, within a reasonable period of time after the date of his objection, access to equivalent goods, services, or disbursements from an alternative provider.
- U. eVA BUSINESS TO GOVERNMENT VENDOR REGISTRATION, CONTRACTS, AND ORDERS: The eVA Internet electronic procurement solution, website portal www.eVA.virginia.gov, streamlines and automates government purchasing activities in the Commonwealth. The eVA portal is the gateway for vendors to conduct business with state agencies and public bodies. All vendors desiring to provide goods and/or services to the Commonwealth shall participate in the eVA Internet eprocurement solution by completing the

free eVA Vendor Registration. All offerors must register in eVA and pay the Vendor Transaction Fees specified below; failure to register will result in the proposal being rejected. Vendor transaction fees are determined by the date the original purchase order is issued and the current fees are as follows:

Vendor transaction fees are determined by the date the original purchase order is issued and the current fees are as follows:

1. For orders issued July 1, 2014 and after, the Vendor Transaction Fee is:
 - a. Department of Small Business and Supplier Diversity (SBSD) certified Small Businesses: 1% capped at \$500 per order.
 - b. Businesses that are not Department of Small Business and Supplier Diversity (SBSD) certified Small Businesses: 1% capped at \$1,500 per order.
2. For orders issued prior to July 1, 2014 the vendor transaction fees can be found at www.eVA.virginia.gov.
3. The specified vendor transaction fee will be invoiced by the Commonwealth of Virginia Department of General Services approximately 60 days after the corresponding purchase order is issued and payable 30 days after the invoice date. Any adjustments (increases/decreases) will be handled through purchase order changes.

V. AVAILABILITY OF FUNDS: It is understood and agreed between the parties herein that the Commonwealth of Virginia shall be bound hereunder only to the extent of the funds available or which may hereafter become available for the purpose of this agreement.

W. PRICING CURRENCY: Unless stated otherwise in the solicitation, offerors shall state offered prices in U.S. dollars.

X. E-VERIFY REQUIREMENT OF ANY CONTRACTOR: Any employer with more than an average of 50 employees for the previous 12 months entering into a contract in excess of \$50,000 with James Madison University to perform work or provide services pursuant to such contract shall register and participate in the E-Verify program to verify information and work authorization of its newly hired employees performing work pursuant to any awarded contract.

Y. CIVILITY IN STATE WORKPLACES: The contractor shall take all reasonable steps to ensure that no individual, while performing work on behalf of the contractor or any subcontractor in connection with this agreement (each, a "Contract Worker"), shall engage in 1) harassment (including sexual harassment), bullying, cyber-bullying, or threatening or violent conduct, or 2) discriminatory behavior on the basis of race, sex, color, national origin, religious belief, sexual orientation, gender identity or expression, age, political affiliation, veteran status, or disability.

The contractor shall provide each Contract Worker with a copy of this Section and will require Contract Workers to participate in training on civility in the State workplace. Upon request, the contractor shall provide documentation that each Contract Worker has received such training.

For purposes of this Section, "State workplace" includes any location, permanent or temporary, where a Commonwealth employee performs any work-related duty or is representing his or her agency, as well as surrounding perimeters, parking lots, outside meeting locations, and means

of travel to and from these locations. Communications are deemed to occur in a State workplace if the Contract Worker reasonably should know that the phone number, email, or other method of communication is associated with a State workplace or is associated with a person who is a State employee.

The Commonwealth of Virginia may require, at its sole discretion, the removal and replacement of any Contract Worker who the Commonwealth reasonably believes to have violated this Section.

This Section creates obligations solely on the part of the contractor. Employees or other third parties may benefit incidentally from this Section and from training materials or other communications distributed on this topic, but the Parties to this agreement intend this Section to be enforceable solely by the Commonwealth and not by employees or other third parties.

- Z. TAXES: Sales to the Commonwealth of Virginia are normally exempt from State sales tax. State sales and use tax certificates of exemption, Form ST-12, will be issued upon request. Deliveries against this contract shall usually be free of Federal excise and transportation taxes. The Commonwealth's excise tax exemption registration number is 54-73-0076K.
- AA. USE OF BRAND NAMES: Unless otherwise provided in this solicitation, the name of a certain brand, make or manufacturer does not restrict offerors to the specific brand, make or manufacturer named, but conveys the general style, type, character, and quality of the article desired. Any article which the public body, in its sole discretion, determines to be the equivalent of that specified, considering quality, workmanship, economy of operation, and suitability for the purpose intended, shall be accepted. The offeror is responsible to clearly and specifically identify the product being offered and to provide sufficient descriptive literature, catalog cuts and technical detail to enable the Commonwealth to determine if the product offered meets the requirements of the solicitation. This is required even if offering the exact brand, make or manufacturer specified. Normally in a competitive sealed solicitation only the information furnished with the proposal will be considered in the evaluation. Failure to furnish adequate data for evaluation purposes may result in declaring a proposal nonresponsive. Unless the offeror clearly indicates in its proposal that the product offered is an equivalent product, such proposal will be considered to offer the brand name product referenced in the solicitation.
- BB. TRANSPORTATION AND PACKAGING: By submitting their proposals, all Offerors certify and warrant that the price offered for FOB destination includes only the actual freight rate costs at the lowest and best rate and is based upon the actual weight of the goods to be shipped. Except as otherwise specified herein, standard commercial packaging, packing and shipping containers shall be used. All shipping containers shall be legibly marked or labeled on the outside with purchase order number, commodity description, and quantity.

VIII. SPECIAL TERMS AND CONDITIONS

- A. AUDIT: The Contractor hereby agrees to retain all books, records, systems, and other documents relative to this contract for five (5) years after final payment, or until audited by the Commonwealth of Virginia, whichever is sooner. The Commonwealth of Virginia, its authorized agents, and/or State auditors shall have full access to and the right to examine any of said materials during said period.
- B. CANCELLATION OF CONTRACT: James Madison University reserves the right to cancel and terminate any resulting contract, in part or in whole, without penalty, upon 60 days written notice to the contractor. In the event the initial contract period is for more than 12 months, the

resulting contract may be terminated by either party, without penalty, after the initial 12 months of the contract period upon 60 days written notice to the other party. Any contract cancellation notice shall not relieve the contractor of the obligation to deliver and/or perform on all outstanding orders issued prior to the effective date of cancellation.

- C. IDENTIFICATION OF PROPOSAL ENVELOPE: The signed proposal should be returned in a separate envelope or package, sealed and identified as follows:

From: _____

Name of Offeror	Due Date	Time
Street or Box No.	RFP #	
City, State, Zip Code	RFP Title	

Name of Purchasing Officer: _____

The envelope should be addressed as directed on the title page of the solicitation.

The Offeror takes the risk that if the envelope is not marked as described above, it may be inadvertently opened and the information compromised, which may cause the proposal to be disqualified. Proposals may be hand-delivered to the designated location in the office issuing the solicitation. No other correspondence or other proposals should be placed in the envelope.

- D. LATE PROPOSALS: To be considered for selection, proposals must be received by the issuing office by the designated date and hour. The official time used in the receipt of proposals is that time on the automatic time stamp machine in the issuing office. Proposals received in the issuing office after the date and hour designated are automatically non responsive and will not be considered. The University is not responsible for delays in the delivery of mail by the U.S. Postal Service, private couriers, or the intra university mail system. It is the sole responsibility of the Offeror to ensure that its proposal reaches the issuing office by the designated date and hour.

- E. UNDERSTANDING OF REQUIREMENTS: It is the responsibility of each offeror to inquire about and clarify any requirements of this solicitation that is not understood. The University will not be bound by oral explanations as to the meaning of specifications or language contained in this solicitation. Therefore, all inquiries deemed to be substantive in nature must be in writing and submitted to the responsible buyer in the Procurement Services Office. Offerors must ensure that written inquiries reach the buyer at least five (5) days prior to the time set for receipt of offerors proposals. A copy of all queries and the respective response will be provided in the form of an addendum to all offerors who have indicated an interest in responding to this solicitation. Your signature on your Offer certifies that you fully understand all facets of this solicitation. These questions may be sent via email directly to the Procurement Officer listed on the signature page of this solicitation or by Fax to 540/568-7935.

- F. RENEWAL OF CONTRACT: This contract may be renewed by the Commonwealth for a period of four (4) successive one year periods under the terms and conditions of the original contract except as stated in 1. and 2. below. Price increases may be negotiated only at the time of renewal. Written notice of the Commonwealth's intention to renew shall be given approximately 90 days prior to the expiration date of each contract period.

1. If the Commonwealth elects to exercise the option to renew the contract for an additional one-year period, the contract price(s) for the additional one year shall not exceed the

contract price(s) of the original contract increased/decreased by no more than the percentage increase/decrease of the other services category of the CPI-W section of the Consumer Price Index of the United States Bureau of Labor Statistics for the latest twelve months for which statistics are available.

2. If during any subsequent renewal periods, the Commonwealth elects to exercise the option to renew the contract, the contract price(s) for the subsequent renewal period shall not exceed the contract price(s) of the previous renewal period increased/decreased by more than the percentage increase/decrease of the other services category of the CPI-W section of the Consumer Price Index of the United States Bureau of Labor Statistics for the latest twelve months for which statistics are available.

- G. SUBMISSION OF INVOICES: All invoices shall be submitted within sixty days of contract term expiration for the initial contract period as well as for each subsequent contract renewal period. Any invoices submitted after the sixty day period will not be processed for payment.
- H. OPERATING VEHICLES ON JAMES MADISON UNIVERSITY CAMPUS: Operating vehicles on sidewalks, plazas, and areas heavily used by pedestrians is prohibited. In the unlikely event a driver should find it necessary to drive on James Madison University sidewalks, plazas, and areas heavily used by pedestrians, the driver must yield to pedestrians. For a complete list of parking regulations, please go to www.jmu.edu/parking; or to acquire a service representative parking permit, contact Parking Services at 540.568.3300. The safety of our students, faculty and staff is of paramount importance to us. Accordingly, violators may be charged.
- I. COOPERATIVE PURCHASING / USE OF AGREEMENT BY THIRD PARTIES: It is the intent of this solicitation and resulting contract(s) to allow for cooperative procurement. Accordingly, any public body, (to include government/state agencies, political subdivisions, etc.), cooperative purchasing organizations, public or private health or educational institutions or any University related foundation and affiliated corporations may access any resulting contract if authorized by the Contractor.

Participation in this cooperative procurement is strictly voluntary. If authorized by the Contractor(s), the resultant contract(s) will be extended to the entities indicated above to purchase goods and services in accordance with contract terms. As a separate contractual relationship, the participating entity will place its own orders directly with the Contractor(s) and shall fully and independently administer its use of the contract(s) to include contractual disputes, invoicing and payments without direct administration from the University. No modification of this contract or execution of a separate agreement is required to participate; however, the participating entity and the Contractor may modify the terms and conditions of this contract to accommodate specific governing laws, regulations, policies, and business goals required by the participating entity. Any such modification will apply solely between the participating entity and the Contractor.

The Contractor will notify the University in writing of any such entities accessing this contract. The Contractor will provide semi-annual usage reports for all entities accessing the contract. The University shall not be held liable for any costs or damages incurred by any other participating entity as a result of any authorization by the Contractor to extend the contract. It is understood and agreed that the University is not responsible for the acts or omissions of any entity and will not be considered in default of the contract no matter the circumstances.

Use of this contract(s) does not preclude any participating entity from using other contracts or competitive processes as needed.

J. SMALL BUSINESS SUBCONTRACTING AND EVIDENCE OF COMPLIANCE:

1. It is the goal of the Commonwealth that 42% of its purchases are made from small businesses. This includes discretionary spending in prime contracts and subcontracts. All potential offerors are required to submit a Small Business Subcontracting Plan. Unless the offeror is registered as a Department of Small Business and Supplier Diversity (SBSD)-certified small business and where it is practicable for any portion of the awarded contract to be subcontracted to other suppliers, the contractor is encouraged to offer such subcontracting opportunities to SBSBD-certified small businesses. This shall not exclude SBSBD-certified women-owned and minority-owned businesses when they have received SBSBD small business certification. No offeror or subcontractor shall be considered a Small Business, a Women-Owned Business or a Minority-Owned Business unless certified as such by the Department of Small Business and Supplier Diversity (SBSD) by the due date for receipt of proposals. If small business subcontractors are used, the prime contractor agrees to report the use of small business subcontractors by providing the purchasing office at a minimum the following information: name of small business with the SBSBD certification number or FEIN, phone number, total dollar amount subcontracted, category type (small, women-owned, or minority-owned), and type of product/service provided. **This information shall be submitted to: JMU Office of Procurement Services, Attn: SWAM Subcontracting Compliance, MSC 5720, Harrisonburg, VA 22807 or swamreporting@jmu.edu .**
2. Each prime contractor who wins an award in which provision of a small business subcontracting plan is a condition of the award, shall deliver to the contracting agency or institution with every request for payment, evidence of compliance (subject only to insubstantial shortfalls and to shortfalls arising from subcontractor default) with the small business subcontracting plan. **This information shall be submitted to: JMU Office of Procurement Services, SWAM Subcontracting Compliance, MSC 5720, Harrisonburg, VA 22807 or swamreporting@jmu.edu .** When such business has been subcontracted to these firms and upon completion of the contract, the contractor agrees to furnish the purchasing office at a minimum the following information: name of firm with the Department of Small Business and Supplier Diversity (SBSD) certification number or FEIN number, phone number, total dollar amount subcontracted, category type (small, women-owned, or minority-owned), and type of product or service provided. Payment(s) may be withheld until compliance with the plan is received and confirmed by the agency or institution. The agency or institution reserves the right to pursue other appropriate remedies to include, but not be limited to, termination for default.
3. Each prime contractor who wins an award valued over \$200,000 shall deliver to the contracting agency or institution with every request for payment, information on use of subcontractors that are not Department of Small Business and Supplier Diversity (SBSD)-certified small businesses. When such business has been subcontracted to these firms and upon completion of the contract, the contractor agrees to furnish the purchasing office at a minimum the following information: name of firm, phone number, FEIN number, total dollar amount subcontracted, and type of product or service provided. **This information shall be submitted to: JMU Office of Procurement Services, Attn: SWAM Subcontracting Compliance, MSC 5720, Harrisonburg, VA 22807 or swamreporting@jmu.edu .**

- K. AUTHORIZATION TO CONDUCT BUSINESS IN THE COMMONWEALTH: A contractor organized as a stock or nonstock corporation, limited liability company, business trust, or limited partnership or registered as a registered limited liability partnership shall be authorized to transact business in the Commonwealth as a domestic or foreign business entity if so required

by Title 13.1 or Title 50 of the Code of Virginia or as otherwise required by law. Any business entity described above that enters into a contract with a public body shall not allow its existence to lapse or its certificate of authority or registration to transact business in the Commonwealth, if so required under Title 13.1 or Title 50, to be revoked or cancelled at any time during the term of the contract. A public body may void any contract with a business entity if the business entity fails to remain in compliance with the provisions of this section.

- L. PUBLIC POSTING OF COOPERATIVE CONTRACTS: James Madison University maintains a web-based contracts database with a public gateway access. Any resulting cooperative contract/s to this solicitation will be posted to the publicly accessible website. Contents identified as proprietary information will not be made public.
- M. CRIMINAL BACKGROUND CHECKS OF PERSONNEL ASSIGNED BY CONTRACTOR TO PERFORM WORK ON JMU PROPERTY: The Contractor shall obtain criminal background checks on all of their contracted employees who will be assigned to perform services on James Madison University property. The results of the background checks will be directed solely to the Contractor. The Contractor bears responsibility for confirming to the University contract administrator that the background checks have been completed prior to work being performed by their employees or subcontractors. The Contractor shall only assign to work on the University campus those individuals whom it deems qualified and permissible based on the results of completed background checks. Notwithstanding any other provision herein, and to ensure the safety of students, faculty, staff and facilities, James Madison University reserves the right to approve or disapprove any contract employee that will work on JMU property. Disapproval by the University will solely apply to JMU property and should have no bearing on the Contractor's employment of an individual outside of James Madison University.
- N. INDEMNIFICATION: Contractor agrees to indemnify, defend and hold harmless the Commonwealth of Virginia, its officers, agents, and employees from any claims, damages and actions of any kind or nature, whether at law or in equity, arising from or caused by the use of any materials, goods, or equipment of any kind or nature furnished by the contractor/any services of any kind or nature furnished by the contractor, provided that such liability is not attributable to the sole negligence of the using agency or to failure of the using agency to use the materials, goods, or equipment in the manner already and permanently described by the contractor on the materials, goods or equipment delivered.
- O. ADDITIONAL GOODS AND SERVICES: The University may acquire other goods or services that the supplier provides than those specifically solicited. The University reserves the right, subject to mutual agreement, for the Contractor to provide additional goods and/or services under the same pricing, terms, and conditions and to make modifications or enhancements to the existing goods and services. Such additional goods and services may include other products, components, accessories, subsystems, or related services that are newly introduced during the term of this Agreement. Such additional goods and services will be provided to the University at favored nations pricing, terms, and conditions.
- P. ADVERTISING: In the event a contract is awarded for supplies, equipment, or services resulting from this proposal, no indication of such sales or services to James Madison University will be used in product literature or advertising without the express written consent of the University. The contractor shall not state in any of its advertising or product literature that James Madison University has purchased or uses any of its products or services, and the contractor shall not include James Madison University in any client list in advertising and promotional materials without the express written consent of the University.

- Q. ELECTRICAL EQUIPMENT STANDARDS: All equipment/material shall conform to the latest issue of all applicable standards as established by National Electrical Manufacturer's Association (NEMA), American National Standards Institute (ANSI), and Occupational Safety & Health Administration (OSHA). All equipment and material, for which there are OSHA standards, shall bear an appropriate label of approval for use intended from a Nationally Recognized Testing Laboratory (NRTL).
- R. CONTRACTOR REGISTRATION: If a contract for construction, removal, repair or improvement of a building or other real property is for \$120,000 or more, or if the total value of all such contracts undertaken by bidder/offeror within any 12-month period is \$750,000 or more, the bidder/offeror is required under Title 54.1-1100, *Code of Virginia* (1950), as amended, to be licensed by the State Board of Contractors a "CLASS A CONTRACTOR." If such a contract is for \$10,000 or more but less than \$120,000, or if the total value of all such contracts undertaken by bidder/offeror within any 12-month period is \$150,000 or more, but less than \$750,000 or more, the bidder is required to be licensed as a "CLASS B CONTRACTOR." If such a contract is over \$1,000 but less than \$10,000, or if the contractor does less than \$150,000 in business in a 12-month period, the bidder is required to be licensed as a "CLASS C CONTRACTOR." The board shall require a master tradesmen license as a condition of licensure for electrical, plumbing and heating, ventilation and air conditioning contractors. The bidder/offeror shall place on the outside of the envelope containing the bid/proposal and shall place in the bid/proposal over his signature whichever of the following notations is appropriate, inserting his contractor license number:
- Licensed Class A Virginia Contractor No. _____ Specialty _____
 Licensed Class B Virginia Contractor No. _____ Specialty _____
 Licensed Class C Virginia Contractor No. _____ Specialty _____
- If the bidder/offeror shall fail to provide this information on his bid/proposal or on the envelope containing the bid/proposal and shall fail to promptly provide said contractor license number to the Commonwealth in writing when requested to do so before or after the opening of bids/proposals, he shall be deemed to be in violation of § 54.1-1115 of the *Code of Virginia* (1950), as amended, and his bid/proposal will not be considered.
- S. CONTRACTOR'S TITLE TO MATERIALS: No materials or supplies for the work shall be purchased by the contractor or by any subcontractor subject to any chattel mortgage or under a conditional sales or other agreement by which an interest is retained by the seller. The contractor warrants that he has clear title to all materials and supplies for which he invoices for payment.
- T. FINAL INSPECTION: At the conclusion of the work, the contractor shall demonstrate to the authorized owners representative that the work is fully operational and in compliance with contract specifications and codes. Any deficiencies shall be promptly and permanently corrected by the contractor at the contractor's sole expense prior to final acceptance of the work.
- U. WARRANTY (COMMERCIAL): The contractor agrees that the goods or services furnished under any award resulting from this solicitation shall be covered by the most favorable commercial warranties the contractor gives any customer for such goods or services and that the rights and remedies provided therein are in addition to and do not limit those available to the Commonwealth by any other clause of this solicitation. A copy of this warranty should be furnished with the bid/proposal.

- V. **WORK SITE DAMAGES:** Any damage to existing utilities, equipment or finished surfaces resulting from the performance of this contract shall be repaired to the Commonwealth's satisfaction at the contractor's expense.

W. **CONTINUITY OF SERVICES:**

- a) The Contractor recognizes that the services under this contract are vital to the Agency and must be continued without interruption and that, upon contract expiration, a successor, either the Agency or another contractor, may continue them. The Contractor agrees:
- (i) To exercise its best efforts and cooperation to effect an orderly and efficient transition to a successor;
 - (ii) To make all Agency owned facilities, equipment, and data available to any successor at an appropriate time prior to the expiration of the contract to facilitate transition to successor; and
 - (iii) That the Agency Contracting Officer shall have final authority to resolve disputes related to the transition of the contract from the Contractor to its successor.
- b) The Contractor shall, upon written notice from the Contract Officer, furnish phase-in/phase-out services for up to ninety (90) days after this contract expires and shall negotiate in good faith a plan with the successor to execute the phase-in/phase-out services. This plan shall be subject to the Contract Officer's approval.
- c) The Contractor shall be reimbursed for all reasonable, pre-approved phase-in/phase-out costs (i.e., costs incurred within the agreed period after contract expiration that result from phase-in, phase-out operations) and a fee (profit) not to exceed a pro rata portion of the fee (profit) under this contract. All phase-in/phase-out work fees must be approved by the Contract Officer in writing prior to commencement of said work.

IX. METHOD OF PAYMENT

The contractor will be paid based on invoices submitted in accordance with the solicitation and any negotiations. James Madison University recognizes the importance of expediting the payment process for our vendors and suppliers; we request that our vendors and suppliers enroll in our bank's Comprehensive Payable options: either the Virtual Payables Virtual Card or the PayMode-X electronic deposit (ACH) to your bank account so that future payments are made electronically. Contractors signed up for the Virtual Payables process will receive the benefit of being paid Net 15. Additional information is available online at:

<http://www.jmu.edu/financeoffice/accounting-operations-disbursements/cash-investments/vendor-payment-methods.shtml>

X. PRICING SCHEDULE

The offeror shall provide pricing for all products and services included in proposal indicating one-time and on-going costs. The resulting contract will be cooperative and pricing shall be inclusive for the attached Zone Map, of which JMU falls within Zone 2.

Pricing shall include a base list rate and a discounted rate for Agencies. Pricing shall include any additional set-up, moving, miscellaneous pricing or fees. Describe all of your company's products and the pricing associated with those products. Pricing will be used as a basis for review. Agencies will be required to contact the awarded vendor with specification/requirements for a thorough estimate.

EXAMPLE: Modular Building Systems

Building Size	List Rate	Discounted Rate
12 X 40 Ft. Building	\$	\$

EXAMPLE: Storage/Shipping Containers

Container Size	List Rate	Discounted Rate
20 Ft. Container	\$	\$
40 Ft. Container	\$	\$

Specify any associated charge card processing fees, if applicable, to be billed to the university. Vendors shall provide their VISA registration number when indicating charge card processing fees. Any vendor requiring information on VISA registration may refer to <https://usa.visa.com/support/small-business/regulations-fees.html> and for questions <https://usa.visa.com/dam/VCOM/global/support-legal/documents/merchant-surcharging-qa-for-web.pdf> .

Specify any associated charge card processing fees, if applicable, to be billed to the university.

XI. ATTACHMENTS

Attachment A: Offeror Data Sheet

Attachment B: Small, Women, and Minority-owned Business (SWaM) Utilization Plan

Attachment C: Standard Contract Sample

Attachment D: Zone Map

Attachment E: VHEPC PAC

Attachment F: SWaM Sub-contractor Reporting Template

ATTACHMENT A

OFFEROR DATA SHEET

TO BE COMPLETED BY OFFEROR

- 1. **QUALIFICATIONS OF OFFEROR:** Offerors must have the capability and capacity in all respects to fully satisfy the contractual requirements.
- 2. **YEARS IN BUSINESS:** Indicate the length of time you have been in business providing these types of goods and services.

Years _____ Months _____

- 3. **REFERENCES:** Indicate below a listing of at least five (5) organizations, either commercial or governmental/educational, that your agency is servicing. Include the name and address of the person the purchasing agency has your permission to contact.

CLIENT	LENGTH OF SERVICE	ADDRESS	CONTACT PERSON/PHONE #

- 4. List full names and addresses of Offeror and any branch offices which may be responsible for administering the contract.

- 5. **RELATIONSHIP WITH THE COMMONWEALTH OF VIRGINIA:** Is any member of the firm an employee of the Commonwealth of Virginia who has a personal interest in this contract pursuant to the [CODE OF VIRGINIA](#), SECTION 2.2-3100 – 3131?

YES NO

IF YES, EXPLAIN: _____

ATTACHMENT B

Small, Women and Minority-owned Businesses (SWaM) Utilization Plan

Offeror Name: _____ Preparer Name: _____

Date: _____

Is your firm a **Small Business Enterprise** certified by the Department of Small Business and Supplier Diversity (SBSD)? Yes_____ No_____

If yes, certification number: _____ Certification date:_____

Is your firm a **Woman-owned Business Enterprise** certified by the Department of Small Business and Supplier Diversity (SBSD)? Yes_____ No_____

If yes, certification number: _____ Certification date:_____

Is your firm a **Minority-Owned Business Enterprise** certified by the Department of Small Business and Supplier Diversity (SBSD)? Yes_____ No_____

If yes, certification number: _____ Certification date:_____

Is your firm a **Micro Business** certified by the Department of Small Business and Supplier Diversity (SBSD)? Yes_____ No_____

If yes, certification number: _____ Certification date: _____

Instructions: *Populate the table below to show your firm's plans for utilization of small, women-owned and minority-owned business enterprises in the performance of the contract. Describe plans to utilize SWAMs businesses as part of joint ventures, partnerships, subcontractors, suppliers, etc.*

Small Business: "Small business " means a business, independently owned or operated by one or more persons who are citizens of the United States or non-citizens who are in full compliance with United States immigration law, which, together with affiliates, has 250 or fewer employees, or average annual gross receipts of \$10 million or less averaged over the previous three years.

Woman-Owned Business Enterprise: A business concern which is at least 51 percent owned by one or more women who are U.S. citizens or legal resident aliens, or in the case of a corporation, partnership or limited liability company or other entity, at least 51 percent of the equity ownership interest in which is owned by one or more women, and whose management and daily business operations are controlled by one or more of such individuals. **For purposes of the SWAM Program, all certified women-owned businesses are also a small business enterprise.**

Minority-Owned Business Enterprise: A business concern which is at least 51 percent owned by one or more minorities or in the case of a corporation, partnership or limited liability company or other entity, at least 51 percent of the equity ownership interest in which is owned by one or more minorities and whose management and daily business operations are controlled by one or more of such individuals. **For purposes of the SWAM Program, all certified minority-owned businesses are also a small business enterprise.**

Micro Business is a certified Small Business under the SWaM Program and has no more than twenty-five (25) employees **AND** no more than \$3 million in average annual revenue over the three-year period prior to their certification.

All small, women, and minority owned businesses must be certified by the Commonwealth of Virginia Department of Small Business and Supplier Diversity (SBSD) to be counted in the SWAM program. Certification applications are available through SBSD at 800-223-0671 in Virginia, 804-786-6585 outside Virginia, or online at <http://www.sbsd.virginia.gov/> (Customer Service).

RETURN OF THIS PAGE IS REQUIRED

ATTACHMENT C



COMMONWEALTH OF VIRGINIA
STANDARD CONTRACT

Contract No. _____

This contract entered into this _____ day of _____ 20____, by _____ hereinafter called the "Contractor" and Commonwealth of Virginia, James Madison University called the "Purchasing Agency".

WITNESSETH that the Contractor and the Purchasing Agency, in consideration of the mutual covenants, promises and agreements herein contained, agree as follows:

SCOPE OF CONTRACT: The Contractor shall provide the services to the Purchasing Agency as set forth in the Contract Documents.

PERIOD OF PERFORMANCE: From _____ through _____

The contract documents shall consist of:

- (1) This signed form;
(2) The following portions of the Request for Proposals dated _____:
(a) The Statement of Needs,
(b) The General Terms and Conditions,
(c) The Special Terms and Conditions together with any negotiated modifications of those Special Conditions;
(d) List each addendum that may be issued
(3) The Contractor's Proposal dated _____ and the following negotiated modification to the Proposal, all of which documents are incorporated herein.
(a) Negotiations summary dated _____.

IN WITNESS WHEREOF, the parties have caused this Contract to be duly executed intending to be bound thereby.

CONTRACTOR:

PURCHASING AGENCY:

By: _____ (Signature)

By: _____ (Signature)

(Printed Name)

(Printed Name)

Title: _____

Title: _____

ATTACHMENT D

Zone Map



Virginia Association of State College & University Purchasing Professionals (VASCUPP)

List of member institutions by zones

<u>Zone 1</u> George Mason University (Fairfax)	<u>Zone 2</u> James Madison University (Harrisonburg)	<u>Zone 3</u> University of Virginia (Charlottesville)
<u>Zone 4</u> University of Mary Washington (Fredericksburg)	<u>Zone 5</u> Christopher Newport University (Newport News) College of William and Mary (Williamsburg) Norfolk State University (Norfolk) Old Dominion University (Norfolk)	<u>Zone 6</u> Virginia Commonwealth University (Richmond) Virginia State University (Petersburg)
<u>Zone 7</u> Longwood University (Farmville)	<u>Zone 8</u> Virginia Military Institute (Lexington) Virginia Tech (Blacksburg) Radford University (Radford)	<u>Zone 9</u> University of Virginia - Wise (Wise)

**AGREEMENT
PUBLICLY ACCESSIBLE CONTRACT (PAC)**

This Agreement, effective the [DAY^{st/nd}] day of [MONTH, YEAR], is by and between James Madison University (the “University”), on behalf of the Virginia Higher Education Procurement Consortium (the “Consortium”) (collectively the "University"), and [VENDOR NAME], (“Vendor”).

TERM

The term of this Agreement shall begin [Date] to [Date] with [Number] of [Number] year renewal options, and an expected final expiration date of [Date]. This end date coincides with the Primary Agreement’s [Agreement Number] end date.

WITNESS

WHEREAS, the University and Vendor have executed an agreement, UCPJMUXXXX, dated MONTH XX, 20XX (the “Primary Agreement”), and included in the Primary Agreement is a third-party access / cooperative clause. Now therefore, the University and Vendor wish to express in this Agreement the specific terms that will allow third party access to the Primary Agreement.

Accordingly, and in consideration of the mutual premises and provisions hereof, the parties hereby agree as follows:

I. Vendor will:

- A. Pay the University 1% of all sales to accessing entities outside of the Consortium membership associated with the Primary Agreement (as the “PAC Annual Fee”). The PAC Annual Fee will be paid/in exchange for marketing services provided by the University and the Consortium described below in Section II.
- B. Fully support this marketing relationship by promoting the availability of the Primary Agreement to non-Consortium entities;
- C. Provide quarterly sales reports detailing the amount of sales to each non-Consortium accessing entity; and

II. The University/Consortium will:

- A. Promote the Primary Agreement on its website and through other channels (e.g., conferences) to non-Consortium members
- B. Maintain an approved version of Vendor’s logo on the Consortium website

III. Payment:

- A. Payment of PAC Annual Fee will arrive at the University no later than August 31 of each year. The University and Consortium will share the payments equally and allocate payments to the appropriate accounts.

In the event of early termination of the Primary Agreement, this residual payment will arrive at the University no later than 45 calendar days from termination date of the Primary Agreement.

- B. Payment of PAC Annual Fee will take the form of a check. Checks will be made payable to the University of Virginia and sent to:

Constance Alexander, Office Manager

Procurement and Supplier Diversity Services
University of Virginia, Carruthers Hall
c/o VHEPC
PO Box 400202
1001 N. Emmet Street
Charlottesville, VA 22904

IV. Notices:

Any notice required or permitted to be given under this Agreement will be in writing and will be deemed duly given: (1) if delivered personally, when received; (2) if sent by recognized overnight courier service, on the date of the receipt provided by such courier service; (3) if sent by registered mail, postage prepaid, return receipt requested, on the date shown on the signed receipt; or (4) if sent by electronic mail, when received (as verified by the email date and time) if delivered no later than 4:00 p.m. (receiver's time) on a business day or on the next business day if delivered (as verified by sender's machine) after 4:00 p.m. (receiver's time) on a business day or on a non-business day. All such notices will be addressed to a party at such party's address or facsimile number as shown below.

If to the University:

Procurement Services
c/o Director of Procurement
James Madison University
752 Ort Street, MSC 5720
Harrisonburg, VA 22807

If to Vendor:

[Vendor Contact]
[Vendor]
[Address]
[City, State, Zip]
Email: [Vendor Email]
Fax: [Fax]

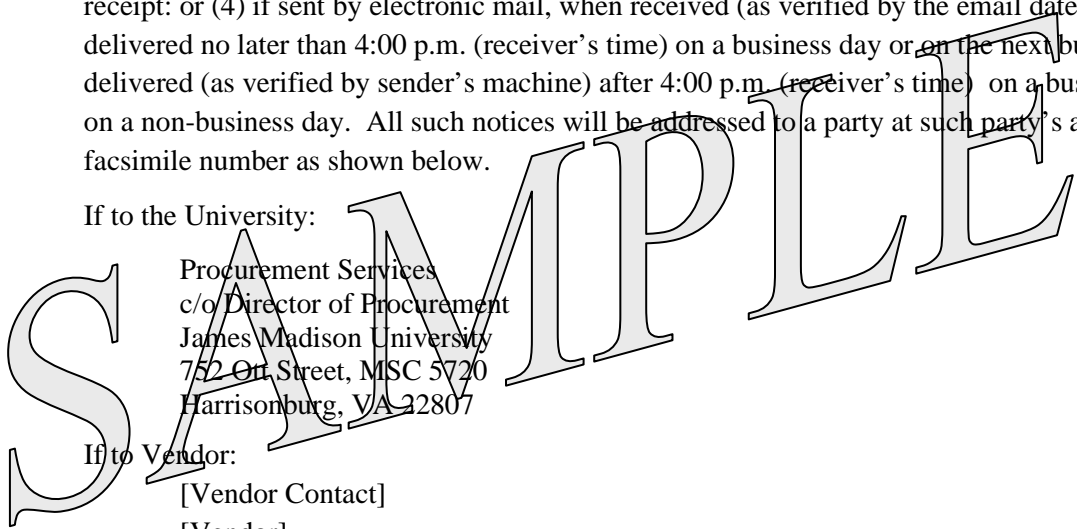

ACCEPTANCE

For James Madison University

For [Vendor]

[Lead Proc]
[Lead Job Title]

[Vendor Contact]
[Vendor Contact Title]

Date

Date

Agreement #: [JMU Contract Number]-PAC

SAMPLE

Reporting Instructions

- 1) Complete all information accurately
- 2) Contact Phillip Ewell (ewellpw@jmu.edu, swamreporting@jmu.edu or 540-568-7999) to discuss questions or concerns with reporting on this form
- 3) Include the Schedule of Values No.(s) that relate to the payments received and being reported on the current reporting (*please note the Schedule of Values number(s) on this report **may not be** the same as the one you are submitting the form with*)
- 4) ALL sub-contractors should be reported, even if they are not currently SWAM certified (*our staff will attempt to contact them to see if they are capable of certifying*)
- 5) The Schedule of Values should be completed entirely with a vendor name included regardless of whether you believe the firm is SWAM or not - this helps for matching between this report and the Schedule of Values - it also helps us to continue to follow up on certifications with vendors that may not be currently certified.
- 6) Suppliers should be reported as they are considered the same as sub-contractors



January 29, 2026

ADDENDUM NO.: One

TO ALL OFFERORS:

REFERENCE: Request for Proposal No: RFP #DKM - 1246
Dated: January 29, 2026
Commodity: *Modular Buildings and Storage Containers*
RFP Closing On: February 12, 2026

Question 1: Is it fair to categorize this solicitation as an IDIQ type procurement mechanism as opposed to a one-time transaction?

Answer: IDIQ is a term used by the Federal Government to describe a similar contract vehicle. JMU does not utilize IDIQs contracts. This RFP will result in a term contract that allows JMU to order goods and/or services as, needed, similar in practice to an IDIQ with awarded vendor(s) and set pricing. The RFP process allows the University to evaluate cost, quality of goods/services, methodology for providing the goods/services, and the experience of the offeror.

Question 2: Would a presentation of our GSA schedule of goods and services serve the purpose?

Answer: Offerors should return a proposal that comprehensively responds to all questions in section IV (Statement of Needs) to be considered a complete response. Offerors may include additional information for consideration at their discretion.

Question 3: Would JMU consider subcontractors being the sole contractor license holder or would the prime contractor have to be the sole contractor license holder?

Answer: The University will consider proposals submitted with the subcontractor as the contractor's license holder, provided they have valid documentation demonstrating that they are the sole license holder.

Question 4: Does the firm submitting the proposal need to have an office in Virginia?

Answer: For the duration of the contract, the prime contractor is not required to maintain an office in Virginia; However, it will be required that either the prime contractor or a valid subcontractor identified in the proposal maintains a Virginia address.

MSC 5720
752 Ott Street, Room 1042
Wine Price Building
Harrisonburg, VA 22807
Office of 540.568.3145 Phone
PROCUREMENT SERVICES 540.568.7935 Fax

Question 5: Are these buildings/containers a specific need for a current project or to be provided on an as-need basis?

Answer: These buildings/containers will be provided on an as-need basis during the length of the contract term.

Signify receipt of this addendum by initialing “*Addendum #1* _____” on the signature page of your proposal.

Sincerely,

Dylan Morris
Buyer Senior
Phone: (540-568-3002)