



COMMONWEALTH OF VIRGINIA
STANDARD CONTRACT

Contract No. UCPJMU7287

This contract entered into this 14th day of August 2025, by The Carpentry and Painting Experts LLC, hereinafter called the "Contractor" and Commonwealth of Virginia, James Madison University called the "Purchasing Agency".

WITNESSETH that the Contractor and the Purchasing Agency, in consideration of the mutual covenants, promises and agreements herein contained, agree as follows:

SCOPE OF CONTRACT: The Contractor shall provide the services to the Purchasing Agency as set forth in the Contract Documents.

PERIOD OF PERFORMANCE: From August 26, 2025, through August 25, 2026, with four (4) one-year renewal options.

The contract documents shall consist of:

- (1) This signed form;
(2) The following portions of the Request for Proposal RFP ADL-1236 dated June 3, 2025
(a) The Statement of Needs,
(b) The General Terms and Conditions,
(c) The Special Terms and Conditions together with any negotiated modifications of those Special Conditions;
(3) The Contractor's Proposal dated July 15, 2025 and the following negotiated modification to the Proposal, all of which documents are incorporated herein.
(a) Negotiations Summary, dated August 12, 2025

IN WITNESS WHEREOF, the parties have caused this Contract to be duly executed intending to be bound thereby.

CONTRACTOR:
By: [Signature]
Hristo Katreva
(Printed Name)

PURCHASING AGENCY:
By: [Signature]
Aaron Largent
(Printed Name)

Title: General Manager

Title: Buyer Senior, VCCO

1. Contact information for The Carpentry Painting Experts.:

Hristo Katrev - General Manager

Phone –804-592-5062

Email – hristo@fixandpaint.net

2. See Pricing Schedule attached. The Purchasing Agency will only pay what's agreed upon in the pricing schedule. Therefore, pricing is set and there shall be no additional fees and/or expenses charged to the University without prior approval.
3. Contractor shall agree to the annual increase amount to be based on the CPI-W scale, other services category, per renewal.
4. The Purchasing Agency will issue a purchase order for goods and services based upon an approved quote provided by Contractor. No work shall be undertaken by the Contractor until a written purchase order is received. The quotes shall include a price breakout showing contract pricing being followed. The Purchasing Agency will not be required to sign and return proposals/quotes.
5. Parties agree that this Negotiation Summary modifies RFP # ADL-1236 and the Contractor's initial response to RFP # ADL-1236, and in the event of conflict this negotiation summary shall take precedence.
6. Contractor agrees that all exceptions taken within their initial response to RFP # ADL-1236 that are not specifically addressed within this negotiation summary are null and void.
7. Any change in the scope described herein shall be mutually agreed upon by the Purchasing Agency and Contractor with all changes first being authorized through either a contract modification and/or a change order issued by the Purchasing Agency.

**RFP # ADL 1236, Ceiling Tile Installation, Drywall  
 and Plastering Services  
 Negotiation Summary for The Carpentry Painting  
 Experts, LLC  
 August 12, 2025**

**Labor Rates**

Ceiling Tile Installation	Regular Working Hours	Overtime Hours
Project manager	95.00	142.50
Lead Crew	95.00	142.50
Helper	50.00	75.00
Plaster Services	Regular Working Hours	Overtime Hours
Project manager	95.00	142.50
Lead Crew	95.00	142.50
Helper	50.00	75.00
Drywall services	Regular Working Hours	Overtime Hours
Project manager	95.00	142.50
Lead Crew	95.00	142.50
Helper	50.00	75.00

**Parts and Supplies**

<b>Materials/Parts</b>	<b>List Price</b>	<b>% Discount Off MSRP</b>	<b>University Price</b>
As Needed			

**Equipment Rentals**

<b>Type of Equipment</b>	<b>Price Breakdown</b>
Lift	Lifts and delivery will be billed at cost to the university
Misc. Other	

**Other Pricing. Specify any associated charge card processing fees, if applicable, to be billed to the university.**

<b>Other Charges or Fees</b>	<b>Amount</b>
Charge Card Processing Fee	N/A
Misc. Other	N/A



# Request for Proposal

## **RFP# ADL-1236**

**Ceiling Tile Installation, Drywall and Plastering  
Services**

**June 03, 2025**



**REQUEST FOR PROPOSAL**  
**RFP# ADL-1236**

**Issue Date:** June 03, 2025  
**Title:** Ceiling Tile installation, Drywall and Plaster Services  
**Issuing Agency:** Commonwealth of Virginia  
James Madison University  
Procurement Services MSC 5720  
752 Ott Street, Wine Price Building  
First Floor, Suite 1023  
Harrisonburg, VA 22807

**Period of Contract: From Date of Award Through One Year (Renewable)**

**Sealed Proposals Will Be Received Until 2:00 PM on July 15, 2025 for Furnishing The Services Described Herein. (See Special Terms & Conditions "D. Late Proposals")**

*SEALED PROPOSALS MAY BE MAILED, EXPRESS MAILED, SUBMITTED IN eVA, OR HAND DELIVERED DIRECTLY TO THE ISSUING AGENCY SHOWN ABOVE.*

All Inquiries For Information And Clarification Should Be Directed To: Aaron Largent, Buyer Senior, Procurement Services, Largenad@jmu.edu; 540-568-4160; (Fax) 540-568-7935 not later than five business days before the proposal closing date.

**NOTE: THE SIGNED PROPOSAL AND ALL ATTACHMENTS SHALL BE RETURNED.**

In compliance with this Request for Proposal and to all the conditions imposed herein, the undersigned offers and agrees to furnish the goods/services in accordance with the attached signed proposal or as mutually agreed upon by subsequent negotiation.

Name and Address of Firm:

The Carpentry and Painting Experts, LLC  
3006 Lincoln Ave  
Richmond, VA, 23228

By:   
(Signature)  
Name: Hristo Katrev  
(Please Print)

Date: 07/15/2025

Title: General Manager

Web Address: www.FixandPaint.net

Phone: 804-997-9703

Email: hristo@fixandpaint.net

Fax #: 888-592-5062

ACKNOWLEDGE RECEIPT OF ADDENDUM: #1 \_\_\_\_\_ #2 \_\_\_\_\_ #3 \_\_\_\_\_ #4 \_\_\_\_\_ #5 \_\_\_\_\_ (please initial)

SMALL, WOMAN OR MINORITY OWNED BUSINESS:

YES;  NO; *IF YES* ⇒⇒  SMALL;  WOMAN;  MINORITY ***IF MINORITY:***  AA;  HA;  AsA;  NW;  Micro

**Note: This public body does not discriminate against faith-based organizations in accordance with the Code of Virginia, § 2.2-4343.1 or against an offeror because of race, religion, color, sex, national origin, age, disability, or any other basis prohibited by state law relating to discrimination in employment.**

# ***REQUEST FOR PROPOSAL***

*RFP # ADL-1236*

## ***TABLE OF CONTENTS***

I.	PURPOSE .....	Page	1
II.	BACKGROUND .....	Page	1
III.	SMALL, WOMAN-OWNED, AND MINORITY PARTICIPATION .....	Page	1
IV.	STATEMENT OF NEEDS .....	Page	1-4
V.	PROPOSAL PREPARATION AND SUBMISSION .....	Page	4-7
VI.	EVALUATION AND AWARD CRITERIA .....	Page	7-8
VII.	GENERAL TERMS AND CONDITIONS .....	Page	8-15
VIII.	SPECIAL TERMS AND CONDITIONS .....	Page	15-21
IX.	METHOD OF PAYMENT .....	Page	21
X.	PRICING SCHEDULE .....	Page	22
XI.	ATTACHMENTS .....	Page	23-28
	A. Offeror Data Sheet		
	B. SWaM Utilization Plan		
	C. Sample of Standard Contract		
	D. Zone Map		
	E. SWaM Standard Reporting Template		
	F. The JMU <a href="#">Design and Construction Guidelines</a> (as amended)		

## **I. PURPOSE**

The purpose of this Request for Proposal (RFP) is to solicit sealed proposals from qualified sources to enter into a contract to provide Ceiling Tile Installation, Drywall and Plastering services for James Madison University (JMU), an agency of the Commonwealth of Virginia. Initial contract shall be for one (1) year with an option to renew for Four (4) additional one-year periods.

## **II. BACKGROUND**

James Madison University (JMU) is a comprehensive public institution in Harrisonburg, Virginia, with an enrollment of approximately 22,000 students and approximately 4,000 faculty and staff. There are over 600 individual departments on campus that support seven (7) academic divisions. The University offers over 120 majors, minors, and concentrations. Further information about the University can be found at the following website: [www.jmu.edu](http://www.jmu.edu).

James Madison University spends on average around \$200,000 annually on ceiling tile, drywall, and plastering services. As the University continues to grow, the need for these services will increase as well.

## **III. SMALL, WOMAN-OWNED AND MINORITY PARTICIPATION**

It is the policy of the Commonwealth of Virginia to contribute to the establishment, preservation, and strengthening of small businesses and businesses owned by women and minorities, and to encourage their participation in State procurement activities. The Commonwealth encourages contractors to provide for the participation of small businesses and businesses owned by women and minorities through partnerships, joint ventures, subcontracts, and other contractual opportunities. Attachment B contains information on reporting spend data with subcontractors.

## **IV. STATEMENT OF NEEDS**

### **A. Scope of Work**

The University has identified three (3) areas where products and services are required:

- 1. Ceiling Tile Installation**
- 2. Drywall Services**
- 3. Plastering Services**

Offerors interested in this solicitation may choose one (1), two (2) or all of the areas under the Statement of Needs section of this RFP to respond to.

The selected contractor(s) shall provide all labor, materials, equipment, transportation, supervision, and incidentals necessary to perform the following services on an as needed basis:

Because this contract shall be multiple awards, projects will be distributed amongst the contractors in the following manner. The University may select any one of the contracted vendors if a project is valued at less than \$200,000. If the project is valued at \$200,000 or more, then all contractors under this contract will be contacted, a site visit shall be held, and a proposal will be requested from each for that particular project. The contractor will

then be selected based on those proposals. No single project under this contract shall exceed \$1,000,000.

### **1. Ceiling Tile Installation**

- Installation of new ceiling tiles in various building types, but not limited to, classrooms, administrative offices, residence halls, and common areas. To include acoustical and decorative ceiling tiles.
- Installation of ceiling tile grid.
- Removal and replacement of damaged or outdated ceiling tiles.

### **2. Drywall Services**

- Installation of new drywall in interior spaces for renovation.
- Repair and removal of existing drywall due to damage, wear, or modifications.
- Taping, sanding, finishing, and preparation for painting.

### **3. Plastering Services**

- Application and repair of plaster finishes on walls and ceilings.
- Restoration of historic or decorative plaster in designated campus buildings as needed.
- Surface preparation, patching, and final finishing.

## **B. Service Requirements**

1. Work shall be performed on an as-needed, on-call basis, with varying project sizes and scopes. There is no guarantee of number or dollar value of project orders.
2. Response time shall occur within 48 hours of initial call. Response shall include quote and estimated time of completion.
3. All services must comply with applicable Virginia building codes, safety standards, and campus guidelines.
4. All project site workspaces shall be maintained in a clean orderly condition.
5. Contractor(s) must be available during regular business hours and occasionally after-hours or weekends for emergency or scheduled projects.
6. Contractor shall obtain a University issued purchase order prior to the commencement of any work.
7. Contractor shall permit the University, its agents, any public authority and their representatives' access to the work area for inspection. All work is subject to final approval by an authorized representative of the University upon completion. The Selected Firm will demonstrate to the University's CA or designee that the work is in compliance with all applicable codes, regulations, project drawings, and specifications for any work resulting from this assessment. Any deficiencies will be promptly corrected by the Selected Firm at its own expense prior to final acceptance of the work.

8. Contractor will be certified by the manufacturer or have established experience on all equipment and supplies for which the Selected Firms will provide or install. The Selected Firm will provide documentation for manufacturer certification and/or references (for previous customers with similar equipment) upon request by the end-using department.
9. All material supplied shall be institutional, industrial, and/or commercial grade, whichever is more stringent, in accordance with the standards of the industry for institutional and/or industrial construction and maintenance in compliance with the JMU Design and Construction Guidelines, see [https://www.jmu.edu/facmgt/fm\\_resources/guidelines/jmu-design-construction-guidelines.pdf](https://www.jmu.edu/facmgt/fm_resources/guidelines/jmu-design-construction-guidelines.pdf)
10. Contractor shall ensure all employees of the Selected Firms are fully trained to perform the services required, including, but not limited to, the handling and disposal of materials in a manner complying with OSHA and EPA standards.
11. All Selected Firm(s) will deliver in-stock product in accordance with delivery expectations of the end-user. Delivery time on any non-stock products will be detailed to the end-user prior to order placement.
12. Contractor shall break down all quotes and invoices in accordance with pricing provided in the PRICING SCHEDULE so as to verify pricing against the contract. The University will not issue a purchase order until an itemized quote is provided.
13. Contractor shall plan its work with the understanding that the University's Housing Division regular working hours are Monday through Friday, 7:30 a.m. until 4:00 p.m., except established holidays observed by the University, unless otherwise approved by an authorized university representative.
14. Contractor shall be required to work under the same conditions as does the University's Housing maintenance employees. This includes, but is not limited to, vehicle parking arranged through the University's Department of Parking and Transportation, complying with all building and safety codes, and scheduling work around the University's class schedules, special events, and holidays.
15. The University's CA or designee must approve all materials/products to be utilized prior to installation.
16. The Selected Firm is responsible for supervising and directing the work of its employees, as well as any subcontractors that may be utilized, by providing the firms best skills and sound judgment. No portion of any work will be subcontracted without prior written consent of the University. Subcontractors which perform work under any Agreement resulting from this RFP will be responsible to the prime contractor. The Selected Firm agrees that it is fully responsible for the acts and omissions of its subcontractors and of persons employed by the subcontractors, as it is for the acts and omissions of its own employees.

**C. Contractor shall provide the following in order for the proposal to be considered a complete response.**

1. Provide the University with labor charges for regular business hours as well as overtime/weekend/emergency hours on the PRICING SCHEDULE.

2. Provide sample quote and invoice. Samples should include how line items contain detailed quantities ordered, individual item cost, and extended total pricing.
3. For additional information needed to complete the proposal, please refer to the Specific Proposal Instructions (Section V Proposal Preparation and Submission; B – Specific Proposal Instructions, Q 1-7/ Pg. 7). **Questions 1-7 must be answered in their entirety for submissions to be considered complete.**

## V. PROPOSAL PREPARATION AND SUBMISSION

### A. GENERAL INSTRUCTIONS

**To ensure timely and adequate consideration of your proposal, offerors are to limit all contact, whether verbal or written, pertaining to this RFP to the James Madison University Procurement Office for the duration of this Proposal process. Failure to do so may jeopardize further consideration of Offeror's proposal.**

**ELECTRONIC OR PAPER SUBMISSIONS MAY BE ACCEPTED FOR THIS PROPOSAL. INSTRUCTIONS BELOW FOR OFFEROR'S CHOSEN METHOD (A. ELECTRONIC SUBMISSION or B. PAPER RESPONSE).**

1. RFP Response: In order to be considered for selection, the **Offeror shall submit a complete response to this RFP**; and shall submit to the issuing Purchasing Agency:

- a. **ELECTRONIC SUBMISSION:**

- i. ELECTRONIC RESPONSES SUBMITTED THROUGH eVA WILL BE ACCEPTED. **Emailed responses will not be accepted.** Please see below, "eVA Procurement Website and Registration" for additional information on registration. It is the responsibility of the Supplier to ensure their proposal and all required documentation is properly completed, readable, and uploaded to eVA. Suppliers should allow sufficient time to account for any technical difficulties they may encounter during online submission or uploading of the documents. In the event of any technical difficulties, Suppliers shall contact the eVA Customer Care Center at 1-866-289-7367 or via email at [eVACustomerCare@DGS.virginia.gov](mailto:eVACustomerCare@DGS.virginia.gov).
- ii. eVA Procurement Website and Registration The Commonwealth's procurement portal, eVA, located at <http://www.eva.virginia.gov>, provides information about Commonwealth solicitations and awards. Suppliers shall be registered in eVA in order submit a proposal to this RFP. To register with eVA, select "Register Now" on the eVA website homepage, <http://www.eva.virginia.gov>. For registration instructions and assistance, as well as instructions on how to submit proposals and accept orders please select "I Sell to Virginia". Suppliers are encouraged to check this site on a regular basis and, in particular, prior to submission of proposals to identify any amendments to the RFP that may have been issued.
- iii. Electronic Responses submitted through eVA shall be in WORD format or searchable PDF of the entire proposal, INCLUDING ALL ATTACHMENTS.

PDFs must be submitted in an unlocked format. Any proprietary information should be clearly marked in accordance with Section V.4.f below.

b. **PAPER SUBMISSIONS:**

- i. **One (1) original and one (1) copies** of the entire proposal, INCLUDING ALL ATTACHMENTS. Any proprietary information should be clearly marked in accordance with V.4.e. below.
  - ii. **One (1) electronic copy in WORD format or searchable PDF (CD or flash drive)** of the entire proposal, INCLUDING ALL ATTACHMENTS. Any proprietary information should be clearly marked in accordance with V.4.f below.
  - iii. Each copy of the proposal should be bound or contained in a single volume where practical. All documentation submitted with the proposal should be contained in that single volume.
  - iv. See additional information in Section VIII.C, *IDENIFICATION OF PROPSAL ENVELOPE*.
2. Should the proposal contain **proprietary information, provide one (1) redacted copy of the proposal** and all attachments with **proprietary portions removed or blacked out**. This copy should be clearly marked "*Redacted Copy*" on the front cover. The classification of an entire proposal document, line-item prices, and/or total proposal prices as proprietary or trade secrets is not acceptable. JMU shall not be responsible for the Contractor's failure to exclude proprietary information from this redacted copy.

No other distribution of the proposal shall be made by the Offeror.

3. The version of the solicitation issued by JMU Procurement Services, as amended by an addenda, is the mandatory controlling version of the document. Any modification of, or additions to, the solicitation by the Offeror shall not modify the official version of the solicitation issued by JMU Procurement services unless accepted in writing by the University. Such modifications or additions to the solicitation by the Offeror may be cause for rejection of the proposal; however, JMU reserves the right to decide, on a case-by-case basis in its sole discretion, whether to reject such a proposal. If the modification or additions are not identified until after the award of the contract, the controlling version of the solicitation document shall still be the official state form issued by Procurement Services.
4. Proposal Preparation
- a. Proposals shall be signed by an authorized representative of the Offeror. All information requested should be submitted. Failure to submit all information requested may result in the purchasing agency requiring prompt submissions of missing information and/or giving a lowered evaluation of the proposal. Proposals which are substantially incomplete or lack key information may be rejected by the purchasing agency. Mandatory requirements are those required by law or regulation or are such that they cannot be waived and are not subject to negotiation.

- b. Proposals shall be prepared simply and economically, providing a straightforward, concise description of capabilities to satisfy the requirements of the RFP. Emphasis should be placed on completeness and clarity of content.
  - c. Proposals should be organized in the order in which the requirements are presented in the RFP. All pages of the proposal should be numbered. Each paragraph in the proposal should reference the paragraph number of the corresponding section of the RFP. It is also helpful to cite the paragraph number, sub letter, and repeat the text of the requirement as it appears in the RFP. If a response covers more than one page, the paragraph number and sub letter should be repeated at the top of the next page. The proposal should contain a table of contents which cross references the RFP requirements. Information which the offeror desires to present that does not fall within any of the requirements of the RFP should be inserted at the appropriate place or be attached at the end of the proposal and designated as additional material. Proposals that are not organized in this manner risk elimination from consideration if the evaluators are unable to find where the RFP requirements are specifically addressed.
  - d. As used in this RFP, the terms “must”, “shall”, “should” and “may” identify the criticality of requirements. “Must” and “shall” identify requirements whose absence will have a major negative impact on the suitability of the proposed solution. Items labeled as “should” or “may” are highly desirable, although their absence will not have a large impact and would be useful, but are not necessary. Depending on the overall response to the RFP, some individual “must” and “shall” items may not be fully satisfied, but it is the intent to satisfy most, if not all, “must” and “shall” requirements. The inability of an offeror to satisfy a “must” or “shall” requirement does not automatically remove that offeror from consideration; however, it may seriously affect the overall rating of the offeror’ proposal.
  - e. Each copy of the proposal should be bound or contained in a single volume where practical. All documentation submitted with the proposal should be contained in that single volume.
  - f. Ownership of all data, materials and documentation originated and prepared for the State pursuant to the RFP shall belong exclusively to the State and be subject to public inspection in accordance with the Virginia Freedom of Information Act. Trade secrets or proprietary information submitted by the offeror shall not be subject to public disclosure under the Virginia Freedom of Information Act; however, the offeror must invoke the protection of Section 2.2-4342F of the Code of Virginia, in writing, either before or at the time the data is submitted. **The written notice must specifically identify the data or materials to be protected and state the reasons why protection is necessary. The proprietary or trade secret materials submitted must be identified by some distinct method such as highlighting or underlining and must indicate only the specific words, figures, or paragraphs that constitute trade secret or proprietary information. The classification of an entire proposal document, line-item prices and/or total proposal prices as proprietary or trade secrets is not acceptable. Marking an entire proposal as confidential or attempts to prevent disclosure of pricing information by designating it as confidential, proprietary or trade secret will be ignored.**
5. Oral Presentation: Offerors who submit a proposal in response to this RFP may be required to give an oral presentation of their proposal to James Madison University. This provides an opportunity for the Offeror to clarify or elaborate on the proposal. This is a fact-finding and explanation session only and does not include negotiation. James Madison University

will schedule the time and location of these presentations. Oral presentations are an option of the University and may or may not be conducted. Therefore, proposals should be complete.

**B. SPECIFIC PROPOSAL INSTRUCTIONS**

Proposals should be as thorough and detailed as possible so that James Madison University may properly evaluate your capabilities to provide the required services. Offerors are required to submit the following items as a complete proposal:

1. Return RFP cover sheet and all addenda acknowledgements, if any, signed and filled out as required. (Electronic signature shall be accepted, i.e. Adobe Sign, DocuSign, etc.)
2. Plan and methodology for providing the goods/services as described in Section IV. Statement of Needs of this Request for Proposal.
3. A written narrative statement to include, but not be limited to, the expertise, qualifications, and experience of the firm and resumes of specific personnel to be assigned to perform the work.
4. Offeror Data Sheet, included as *Attachment A* to this RFP.
5. Small Business Subcontracting Plan, included as *Attachment B* to this RFP. Offeror shall provide a Small Business Subcontracting plan which summarizes the planned utilization of Department of Small Business and Supplier Diversity (SBSD)-certified small businesses which include businesses owned by women and minorities, when they have received Department of Small Business and Supplier Diversity (SBSD) small business certification, under the contract to be awarded as a result of this solicitation. This is a requirement for all prime contracts in excess of \$100,000 unless no subcontracting opportunities exist.
6. Identify the amount of sales your company had during the last twelve months with each VASCUPP Member Institution. A list of VASCUPP Members can be found at: [www.VASCUPP.org](http://www.VASCUPP.org).
7. Proposed Cost. See Section X. Pricing Schedule of this Request for Proposal.

**VI. EVALUATION AND AWARD CRITERIA**

**A. EVALUATION CRITERIA**

Proposals shall be evaluated by James Madison University using the following criteria:

	<u>Points</u>
1. Quality of products/services offered and suitability for intended purposes	25
2. Qualifications and experience of Offeror in providing the goods/services	25
3. Specific plans or methodology to be used to perform the services	25
4. Participation of Small, Women-Owned, & Minority (SWaM) Businesses	10

AWARD TO MULTIPLE OFFERORS: Selection shall be made of two or more offerors deemed to be fully qualified and best suited among those submitting proposals on the basis of the evaluation factors included in the Request for Proposals, including price, if so stated in the Request for Proposals. Negotiations shall be conducted with the offerors so selected. Price shall be considered, but need not be the sole determining factor. After negotiations have been conducted with each offeror so selected, the agency shall select the offeror which, in its opinion, has made the best proposal, and shall award the contract to that offeror. The Commonwealth reserves the right to make multiple awards as a result of this solicitation. The Commonwealth may cancel this Request for Proposals or reject proposals at any time prior to an award, and is not required to furnish a statement of the reasons why a particular proposal was not deemed to be the most advantageous. Should the Commonwealth determine in writing and in its sole discretion that only one offeror is fully qualified, or that one offeror is clearly more highly qualified than the others under consideration, a contract may be negotiated and awarded to that offeror. The award document will be a contract incorporating by reference all the requirements, terms and conditions of the solicitation and the contractor's proposal as negotiated.

## VII. GENERAL TERMS AND CONDITIONS

- A. PURCHASING MANUAL: This solicitation is subject to the provisions of the Commonwealth of Virginia's Purchasing Manual for Institutions of Higher Education and Their Vendors and any revisions thereto, which are hereby incorporated into this contract in their entirety. A copy of the manual is available for review at the purchasing office. In addition, the manual may be accessed electronically at <http://www.jmu.edu/procurement> or a copy can be obtained by calling Procurement Services at (540) 568-3145.
- B. APPLICABLE LAWS AND COURTS: This solicitation and any resulting contract shall be governed in all respects by the laws of the Commonwealth of Virginia and any litigation with respect thereto shall be brought in the courts of the Commonwealth. The Contractor shall comply with applicable federal, state and local laws and regulations.
- C. ANTI-DISCRIMINATION: By submitting their proposals, offerors certify to the Commonwealth that they will conform to the provisions of the Federal Civil Rights Act of 1964, as amended, as well as the Virginia Fair Employment Contracting Act of 1975, as amended, where applicable, the Virginians With Disabilities Act, the Americans With Disabilities Act and §10 of the Rules Governing Procurement, Chapter 2, Exhibit J, Attachment 1 (available for review at <http://www.jmu.edu/procurement>). If the award is made to a faith-based organization, the organization shall not discriminate against any recipient of goods, services, or disbursements made pursuant to the contract on the basis of the recipient's religion, religious belief, refusal to participate in a religious practice, or on the basis of race, age, color, gender, sexual orientation, gender identity, or national origin and shall be subject to the same rules as other organizations that contract with public bodies to account for the use of the funds provided; however, if the faith-based organization segregates public funds into separate accounts, only the accounts and programs funded with public funds shall be subject to audit by the public body. (*§6 of the Rules Governing Procurement*).

In every contract over \$10,000 the provisions in 1. and 2. below apply:

1. During the performance of this contract, the contractor agrees as follows:
    - a. The contractor will not discriminate against any employee or applicant for employment because of race, religion, color, sex, sexual orientation, gender identity, national origin, age, disability, or any other basis prohibited by state law relating to discrimination in employment, except where there is a bona fide occupational qualification reasonably necessary to the normal operation of the contractor. The contractor agrees to post in conspicuous places, available to employees and applicants for employment, notices setting forth the provisions of this nondiscrimination clause.
    - b. The contractor, in all solicitations or advertisements for employees placed by or on behalf of the contractor, will state that such contractor is an equal opportunity employer.
    - c. Notices, advertisements, and solicitations placed in accordance with federal law, rule, or regulation shall be deemed sufficient for the purpose of meeting these requirements.
  2. The contractor will include the provisions of 1. above in every subcontract or purchase order over \$10,000, so that the provisions will be binding upon each subcontractor or vendor.
- D. ETHICS IN PUBLIC CONTRACTING: By submitting their proposals, offerors certify that their proposals are made without collusion or fraud and that they have not offered or received any kickbacks or inducements from any other offeror, supplier, manufacturer or subcontractor in connection with their proposal, and that they have not conferred on any public employee having official responsibility for this procurement transaction any payment, loan, subscription, advance, deposit of money, services or anything of more than nominal value, present or promised, unless consideration of substantially equal or greater value was exchanged.
- E. IMMIGRATION REFORM AND CONTROL ACT OF 1986: By entering into a written contract with the Commonwealth of Virginia, the Contractor certifies that the Contractor does not, and shall not during the performance of the contract for goods and services in the Commonwealth, knowingly employ an unauthorized alien as defined in the federal Immigration Reform and Control Act of 1986.
- F. DEBARMENT STATUS: By submitting their proposals, offerors certify that they are not currently debarred by the Commonwealth of Virginia from submitting proposals on contracts for the type of goods and/or services covered by this solicitation, nor are they an agent of any person or entity that is currently so debarred.
- G. ANTITRUST: By entering into a contract, the contractor conveys, sells, assigns, and transfers to the Commonwealth of Virginia all rights, title and interest in and to all causes of action it may now have or hereafter acquire under the antitrust laws of the United States and the Commonwealth of Virginia, relating to the particular goods or services purchased or acquired by the Commonwealth of Virginia under said contract.
- H. MANDATORY USE OF STATE FORM AND TERMS AND CONDITIONS RFPs: Failure to submit a proposal on the official state form provided for that purpose may be a cause for rejection of the proposal. Modification of or additions to the General Terms and Conditions of the solicitation may be cause for rejection of the proposal; however, the Commonwealth reserves the right to decide, on a case by case basis, in its sole discretion, whether to reject such a proposal.

I. CLARIFICATION OF TERMS: If any prospective offeror has questions about the specifications or other solicitation documents, the prospective offeror should contact the buyer whose name appears on the face of the solicitation no later than five working days before the due date. Any revisions to the solicitation will be made only by addendum issued by the buyer.

J. PAYMENT:

1. To Prime Contractor:

- a. Invoices for items ordered, delivered and accepted shall be submitted by the contractor directly to the payment address shown on the purchase order/contract. All invoices shall show the state contract number and/or purchase order number; social security number (for individual contractors) or the federal employer identification number (for proprietorships, partnerships, and corporations).
- b. Any payment terms requiring payment in less than 30 days will be regarded as requiring payment 30 days after invoice or delivery, whichever occurs last. This shall not affect offers of discounts for payment in less than 30 days, however.
- c. All goods or services provided under this contract or purchase order, that are to be paid for with public funds, shall be billed by the contractor at the contract price, regardless of which public agency is being billed.
- d. The following shall be deemed to be the date of payment: the date of postmark in all cases where payment is made by mail, or the date of offset when offset proceedings have been instituted as authorized under the Virginia Debt Collection Act.
- e. Unreasonable Charges. Under certain emergency procurements and for most time and material purchases, final job costs cannot be accurately determined at the time orders are placed. In such cases, contractors should be put on notice that final payment in full is contingent on a determination of reasonableness with respect to all invoiced charges. Charges which appear to be unreasonable will be researched and challenged, and that portion of the invoice held in abeyance until a settlement can be reached. Upon determining that invoiced charges are not reasonable, the Commonwealth shall promptly notify the contractor, in writing, as to those charges which it considers unreasonable and the basis for the determination. A contractor may not institute legal action unless a settlement cannot be reached within thirty (30) days of notification. The provisions of this section do not relieve an agency of its prompt payment obligations with respect to those charges which are not in dispute (*Rules Governing Procurement, Chapter 2, Exhibit J, Attachment 1 § 53; available for review at <http://www.jmu.edu/procurement>*).

2. To Subcontractors:

- a. A contractor awarded a contract under this solicitation is hereby obligated:

- (1) To pay the subcontractor(s) within seven (7) days of the contractor's receipt of payment from the Commonwealth for the proportionate share of the payment received for work performed by the subcontractor(s) under the contract; or
  - (2) To notify the agency and the subcontractors, in writing, of the contractor's intention to withhold payment and the reason.
- b. The contractor is obligated to pay the subcontractor(s) interest at the rate of one percent per month (unless otherwise provided under the terms of the contract) on all amounts owed by the contractor that remain unpaid seven (7) days following receipt of payment from the Commonwealth, except for amounts withheld as stated in (2) above. The date of mailing of any payment by U. S. Mail is deemed to be payment to the addressee. These provisions apply to each sub-tier contractor performing under the primary contract. A contractor's obligation to pay an interest charge to a subcontractor may not be construed to be an obligation of the Commonwealth.
3. Each prime contractor who wins an award in which provision of a SWAM procurement plan is a condition to the award, shall deliver to the contracting agency or institution, on or before request for final payment, evidence and certification of compliance (subject only to insubstantial shortfalls and to shortfalls arising from subcontractor default) with the SWAM procurement plan. Final payment under the contract in question may be withheld until such certification is delivered and, if necessary, confirmed by the agency or institution, or other appropriate penalties may be assessed in lieu of withholding such payment.
  4. The Commonwealth of Virginia encourages contractors and subcontractors to accept electronic and credit card payments.
- K. PRECEDENCE OF TERMS: Paragraphs A through J of these General Terms and Conditions and the Commonwealth of Virginia Purchasing Manual for Institutions of Higher Education and their Vendors, shall apply in all instances. In the event there is a conflict between any of the other General Terms and Conditions and any Special Terms and Conditions in this solicitation, the Special Terms and Conditions shall apply.
- L. QUALIFICATIONS OF OFFERORS: The Commonwealth may make such reasonable investigations as deemed proper and necessary to determine the ability of the offeror to perform the services/furnish the goods and the offeror shall furnish to the Commonwealth all such information and data for this purpose as may be requested. The Commonwealth reserves the right to inspect offeror's physical facilities prior to award to satisfy questions regarding the offeror's capabilities. The Commonwealth further reserves the right to reject any proposal if the evidence submitted by, or investigations of, such offeror fails to satisfy the Commonwealth that such offeror is properly qualified to carry out the obligations of the contract and to provide the services and/or furnish the goods contemplated therein.
- M. TESTING AND INSPECTION: The Commonwealth reserves the right to conduct any test/inspection it may deem advisable to assure goods and services conform to the specifications.
- N. ASSIGNMENT OF CONTRACT: A contract shall not be assignable by the contractor in whole or in part without the written consent of the Commonwealth.
- O. CHANGES TO THE CONTRACT: Changes can be made to the contract in any of the following ways:

1. The parties may agree in writing to modify the scope of the contract. An increase or decrease in the price of the contract resulting from such modification shall be agreed to by the parties as a part of their written agreement to modify the scope of the contract.
  2. The Purchasing Agency may order changes within the general scope of the contract at any time by written notice to the contractor. Changes within the scope of the contract include, but are not limited to, things such as services to be performed, the method of packing or shipment, and the place of delivery or installation. The contractor shall comply with the notice upon receipt. The contractor shall be compensated for any additional costs incurred as the result of such order and shall give the Purchasing Agency a credit for any savings. Said compensation shall be determined by one of the following methods:
    - a. By mutual agreement between the parties in writing; or
    - b. By agreeing upon a unit price or using a unit price set forth in the contract, if the work to be done can be expressed in units, and the contractor accounts for the number of units of work performed, subject to the Purchasing Agency's right to audit the contractor's records and/or to determine the correct number of units independently; or
    - c. By ordering the contractor to proceed with the work and keep a record of all costs incurred and savings realized. A markup for overhead and profit may be allowed if provided by the contract. The same markup shall be used for determining a decrease in price as the result of savings realized. The contractor shall present the Purchasing Agency with all vouchers and records of expenses incurred and savings realized. The Purchasing Agency shall have the right to audit the records of the contractor as it deems necessary to determine costs or savings. Any claim for an adjustment in price under this provision must be asserted by written notice to the Purchasing Agency within thirty (30) days from the date of receipt of the written order from the Purchasing Agency. If the parties fail to agree on an amount of adjustment, the question of an increase or decrease in the contract price or time for performance shall be resolved in accordance with the procedures for resolving disputes provided by the Disputes Clause of this contract or, if there is none, in accordance with the disputes provisions of the Commonwealth of Virginia Purchasing Manual for Institutions of Higher Education and their Vendors. Neither the existence of a claim nor a dispute resolution process, litigation or any other provision of this contract shall excuse the contractor from promptly complying with the changes ordered by the Purchasing Agency or with the performance of the contract generally.
- P. DEFAULT: In case of failure to deliver goods or services in accordance with the contract terms and conditions, the Commonwealth, after due oral or written notice, may procure them from other sources and hold the contractor responsible for any resulting additional purchase and administrative costs. This remedy shall be in addition to any other remedies which the Commonwealth may have.
- Q. INSURANCE: By signing and submitting a proposal under this solicitation, the offeror certifies that if awarded the contract, it will have the following insurance coverage at the time the contract is awarded. For construction contracts, if any subcontractors are involved, the subcontractor will have workers' compensation insurance in accordance with § 25 of the Rules Governing Procurement – Chapter 2, Exhibit J, Attachment 1, and 65.2-800 et. Seq. of the Code of Virginia (available for review at <http://www.jmu.edu/procurement>) The offeror further certifies that the contractor and any subcontractors will maintain these insurance coverage during the entire term of the contract and that all insurance coverage will be provided

by insurance companies authorized to sell insurance in Virginia by the Virginia State Corporation Commission.

MINIMUM INSURANCE COVERAGES AND LIMITS REQUIRED FOR MOST CONTRACTS:

1. Workers' Compensation: Statutory requirements and benefits. Coverage is compulsory for employers of three or more employees, to include the employer. Contractors who fail to notify the Commonwealth of increases in the number of employees that change their workers' compensation requirement under the Code of Virginia during the course of the contract shall be in noncompliance with the contract.
2. Employer's Liability: \$100,000
3. Commercial General Liability: \$1,000,000 per occurrence and \$2,000,000 in the aggregate. Commercial General Liability is to include bodily injury and property damage, personal injury and advertising injury, products and completed operations coverage. The Commonwealth of Virginia must be named as an additional insured and so endorsed on the policy.
4. Automobile Liability: \$1,000,000 combined single limit. *(Required only if a motor vehicle not owned by the Commonwealth is to be used in the contract. Contractor must assure that the required coverage is maintained by the Contractor (or third party owner of such motor vehicle.)*

R. ANNOUNCEMENT OF AWARD: Upon the award or the announcement of the decision to award a contract over \$100,000, as a result of this solicitation, the purchasing agency will publicly post such notice on the DGS/DPS eVA web site ([www.eva.virginia.gov](http://www.eva.virginia.gov)) for a minimum of 10 days.

S. DRUG-FREE WORKPLACE: During the performance of this contract, the contractor agrees to (i) provide a drug-free workplace for the contractor's employees; (ii) post in conspicuous places, available to employees and applicants for employment, a statement notifying employees that the unlawful manufacture, sale, distribution, dispensation, possession, or use of a controlled substance or marijuana is prohibited in the contractor's workplace and specifying the actions that will be taken against employees for violations of such prohibition; (iii) state in all solicitations or advertisements for employees placed by or on behalf of the contractor that the contractor maintains a drug-free workplace; and (iv) include the provisions of the foregoing clauses in every subcontract or purchase order of over \$10,000, so that the provisions will be binding upon each subcontractor or vendor.

For the purposes of this section, "drug-free workplace" means a site for the performance of work done in connection with a specific contract awarded to a contractor, the employees of whom are prohibited from engaging in the unlawful manufacture, sale, distribution, dispensation, possession or use of any controlled substance or marijuana during the performance of the contract.

T. NONDISCRIMINATION OF CONTRACTORS: An offeror, or contractor shall not be discriminated against in the solicitation or award of this contract because of race, religion, color, sex, sexual orientation, gender identity, national origin, age, disability, faith-based organizational status, any other basis prohibited by state law relating to discrimination in employment or because the offeror employs ex-offenders unless the state agency, department

or institution has made a written determination that employing ex-offenders on the specific contract is not in its best interest. If the award of this contract is made to a faith-based organization and an individual, who applies for or receives goods, services, or disbursements provided pursuant to this contract objects to the religious character of the faith-based organization from which the individual receives or would receive the goods, services, or disbursements, the public body shall offer the individual, within a reasonable period of time after the date of his objection, access to equivalent goods, services, or disbursements from an alternative provider.

- U. eVA BUSINESS TO GOVERNMENT VENDOR REGISTRATION, CONTRACTS, AND ORDERS: The eVA Internet electronic procurement solution, website portal [www.eVA.virginia.gov](http://www.eVA.virginia.gov), streamlines and automates government purchasing activities in the Commonwealth. The eVA portal is the gateway for vendors to conduct business with state agencies and public bodies. All vendors desiring to provide goods and/or services to the Commonwealth shall participate in the eVA Internet eprocurement solution by completing the free eVA Vendor Registration. All offerors must register in eVA and pay the Vendor Transaction Fees specified below; failure to register will result in the proposal being rejected. Vendor transaction fees are determined by the date the original purchase order is issued and the current fees are as follows:

Vendor transaction fees are determined by the date the original purchase order is issued and the current fees are as follows:

1. For orders issued July 1, 2014 and after, the Vendor Transaction Fee is:
  - a. Department of Small Business and Supplier Diversity (SBSD) certified Small Businesses: 1% capped at \$500 per order.
  - b. Businesses that are not Department of Small Business and Supplier Diversity (SBSD) certified Small Businesses: 1% capped at \$1,500 per order.
2. For orders issued prior to July 1, 2014 the vendor transaction fees can be found at [www.eVA.virginia.gov](http://www.eVA.virginia.gov).
3. The specified vendor transaction fee will be invoiced by the Commonwealth of Virginia Department of General Services approximately 60 days after the corresponding purchase order is issued and payable 30 days after the invoice date. Any adjustments (increases/decreases) will be handled through purchase order changes.

- V. AVAILABILITY OF FUNDS: It is understood and agreed between the parties herein that the Commonwealth of Virginia shall be bound hereunder only to the extent of the funds available or which may hereafter become available for the purpose of this agreement.

- W. PRICING CURRENCY: Unless stated otherwise in the solicitation, offerors shall state offered prices in U.S. dollars.

- X. E-VERIFY REQUIREMENT OF ANY CONTRACTOR: Any employer with more than an average of 50 employees for the previous 12 months entering into a contract in excess of \$50,000 with James Madison University to perform work or provide services pursuant to such contract shall register and participate in the E-Verify program to verify information and work authorization of its newly hired employees performing work pursuant to any awarded contract.



Street or Box No.	RFP #
City, State, Zip Code	RFP Title
Name of Purchasing Officer:	

The envelope should be addressed as directed on the title page of the solicitation.

The Offeror takes the risk that if the envelope is not marked as described above, it may be inadvertently opened and the information compromised, which may cause the proposal to be disqualified. Proposals may be hand-delivered to the designated location in the office issuing the solicitation. No other correspondence or other proposals should be placed in the envelope.

- D. **LATE PROPOSALS:** To be considered for selection, proposals must be received by the issuing office by the designated date and hour. The official time used in the receipt of proposals is that time on the automatic time stamp machine in the issuing office. Proposals received in the issuing office after the date and hour designated are automatically non responsive and will not be considered. The University is not responsible for delays in the delivery of mail by the U.S. Postal Service, private couriers, or the intra university mail system. It is the sole responsibility of the Offeror to ensure that its proposal reaches the issuing office by the designated date and hour.
- E. **UNDERSTANDING OF REQUIREMENTS:** It is the responsibility of each offeror to inquire about and clarify any requirements of this solicitation that is not understood. The University will not be bound by oral explanations as to the meaning of specifications or language contained in this solicitation. Therefore, all inquiries deemed to be substantive in nature must be in writing and submitted to the responsible buyer in the Procurement Services Office. Offerors must ensure that written inquiries reach the buyer at least five (5) days prior to the time set for receipt of offerors proposals. A copy of all queries and the respective response will be provided in the form of an addendum to all offerors who have indicated an interest in responding to this solicitation. Your signature on your Offer certifies that you fully understand all facets of this solicitation. These questions may be sent via email directly to the Procurement Officer listed on the signature page of this solicitation or by Fax to 540/568-7935.
- F. **RENEWAL OF CONTRACT:** This contract may be renewed by the Commonwealth for a period of four (4) successive one year periods under the terms and conditions of the original contract except as stated in 1. and 2. below. Price increases may be negotiated only at the time of renewal. Written notice of the Commonwealth's intention to renew shall be given approximately 90 days prior to the expiration date of each contract period.
1. If the Commonwealth elects to exercise the option to renew the contract for an additional one-year period, the contract price(s) for the additional one year shall not exceed the contract price(s) of the original contract increased/decreased by no more than the percentage increase/decrease of the other services category of the CPI-W section of the Consumer Price Index of the United States Bureau of Labor Statistics for the latest twelve months for which statistics are available.
  2. If during any subsequent renewal periods, the Commonwealth elects to exercise the option to renew the contract, the contract price(s) for the subsequent renewal period shall not exceed the contract price(s) of the previous renewal period increased/decreased by more than the percentage increase/decrease of the other services category of the CPI-W section of the Consumer Price Index of the United States Bureau of Labor Statistics for the latest twelve months for which statistics are available.

- G. SUBMISSION OF INVOICES: All invoices shall be submitted within sixty days of contract term expiration for the initial contract period as well as for each subsequent contract renewal period. Any invoices submitted after the sixty day period will not be processed for payment.
- H. OPERATING VEHICLES ON JAMES MADISON UNIVERSITY CAMPUS: Operating vehicles on sidewalks, plazas, and areas heavily used by pedestrians is prohibited. In the unlikely event a driver should find it necessary to drive on James Madison University sidewalks, plazas, and areas heavily used by pedestrians, the driver must yield to pedestrians. For a complete list of parking regulations, please go to [www.jmu.edu/parking](http://www.jmu.edu/parking); or to acquire a service representative parking permit, contact Parking Services at 540.568.3300. The safety of our students, faculty and staff is of paramount importance to us. Accordingly, violators may be charged.
- I. COOPERATIVE PURCHASING / USE OF AGREEMENT BY THIRD PARTIES: It is the intent of this solicitation and resulting contract(s) to allow for cooperative procurement. Accordingly, any public body, (to include government/state agencies, political subdivisions, etc.), cooperative purchasing organizations, public or private health or educational institutions or any University related foundation and affiliated corporations may access any resulting contract if authorized by the Contractor.

Participation in this cooperative procurement is strictly voluntary. If authorized by the Contractor(s), the resultant contract(s) will be extended to the entities indicated above to purchase goods and services in accordance with contract terms. As a separate contractual relationship, the participating entity will place its own orders directly with the Contractor(s) and shall fully and independently administer its use of the contract(s) to include contractual disputes, invoicing and payments without direct administration from the University. No modification of this contract or execution of a separate agreement is required to participate; however, the participating entity and the Contractor may modify the terms and conditions of this contract to accommodate specific governing laws, regulations, policies, and business goals required by the participating entity. Any such modification will apply solely between the participating entity and the Contractor.

The Contractor will notify the University in writing of any such entities accessing this contract. The Contractor will provide semi-annual usage reports for all entities accessing the contract. The University shall not be held liable for any costs or damages incurred by any other participating entity as a result of any authorization by the Contractor to extend the contract. It is understood and agreed that the University is not responsible for the acts or omissions of any entity and will not be considered in default of the contract no matter the circumstances.

Use of this contract(s) does not preclude any participating entity from using other contracts or competitive processes as needed.

- J. SMALL BUSINESS SUBCONTRACTING AND EVIDENCE OF COMPLIANCE:
1. It is the goal of the Commonwealth that 42% of its purchases are made from small businesses. This includes discretionary spending in prime contracts and subcontracts. All potential offerors are required to submit a Small Business Subcontracting Plan. Unless the offeror is registered as a Department of Small Business and Supplier Diversity (SBSD)-certified small business and where it is practicable for any portion of the awarded contract to be subcontracted to other suppliers, the contractor is encouraged to offer such subcontracting opportunities to SBSBD-certified small businesses. This shall not exclude SBSBD-certified women-owned and minority-owned businesses when they have received

SBSD small business certification. No offeror or subcontractor shall be considered a Small Business, a Women-Owned Business or a Minority-Owned Business unless certified as such by the Department of Small Business and Supplier Diversity (SBSD) by the due date for receipt of proposals. If small business subcontractors are used, the prime contractor agrees to report the use of small business subcontractors by providing the purchasing office at a minimum the following information: name of small business with the SBSD certification number or FEIN, phone number, total dollar amount subcontracted, category type (small, women-owned, or minority-owned), and type of product/service provided. **This information shall be submitted to: JMU Office of Procurement Services, Attn: SWAM Subcontracting Compliance, MSC 5720, Harrisonburg, VA 22807 or [swamreporting@jmu.edu](mailto:swamreporting@jmu.edu) .**

2. Each prime contractor who wins an award in which provision of a small business subcontracting plan is a condition of the award, shall deliver to the contracting agency or institution with every request for payment, evidence of compliance (subject only to insubstantial shortfalls and to shortfalls arising from subcontractor default) with the small business subcontracting plan. **This information shall be submitted to: JMU Office of Procurement Services, SWAM Subcontracting Compliance, MSC 5720, Harrisonburg, VA 22807 or [swamreporting@jmu.edu](mailto:swamreporting@jmu.edu) .** When such business has been subcontracted to these firms and upon completion of the contract, the contractor agrees to furnish the purchasing office at a minimum the following information: name of firm with the Department of Small Business and Supplier Diversity (SBSD) certification number or FEIN number, phone number, total dollar amount subcontracted, category type (small, women-owned, or minority-owned), and type of product or service provided. Payment(s) may be withheld until compliance with the plan is received and confirmed by the agency or institution. The agency or institution reserves the right to pursue other appropriate remedies to include, but not be limited to, termination for default.
  3. Each prime contractor who wins an award valued over \$200,000 shall deliver to the contracting agency or institution with every request for payment, information on use of subcontractors that are not Department of Small Business and Supplier Diversity (SBSD)-certified small businesses. When such business has been subcontracted to these firms and upon completion of the contract, the contractor agrees to furnish the purchasing office at a minimum the following information: name of firm, phone number, FEIN number, total dollar amount subcontracted, and type of product or service provided. **This information shall be submitted to: JMU Office of Procurement Services, Attn: SWAM Subcontracting Compliance, MSC 5720, Harrisonburg, VA 22807 or [swamreporting@jmu.edu](mailto:swamreporting@jmu.edu) .**
- K. AUTHORIZATION TO CONDUCT BUSINESS IN THE COMMONWEALTH: A contractor organized as a stock or nonstock corporation, limited liability company, business trust, or limited partnership or registered as a registered limited liability partnership shall be authorized to transact business in the Commonwealth as a domestic or foreign business entity if so required by Title 13.1 or Title 50 of the Code of Virginia or as otherwise required by law. Any business entity described above that enters into a contract with a public body shall not allow its existence to lapse or its certificate of authority or registration to transact business in the Commonwealth, if so required under Title 13.1 or Title 50, to be revoked or cancelled at any time during the term of the contract. A public body may void any contract with a business entity if the business entity fails to remain in compliance with the provisions of this section.
- L. PUBLIC POSTING OF COOPERATIVE CONTRACTS: James Madison University maintains a web-based contracts database with a public gateway access. Any resulting

cooperative contract/s to this solicitation will be posted to the publicly accessible website. Contents identified as proprietary information will not be made public.

- M. CRIMINAL BACKGROUND CHECKS OF PERSONNEL ASSIGNED BY CONTRACTOR TO PERFORM WORK ON JMU PROPERTY: The Contractor shall obtain criminal background checks on all of their contracted employees who will be assigned to perform services on James Madison University property. The results of the background checks will be directed solely to the Contractor. The Contractor bears responsibility for confirming to the University contract administrator that the background checks have been completed prior to work being performed by their employees or subcontractors. The Contractor shall only assign to work on the University campus those individuals whom it deems qualified and permissible based on the results of completed background checks. Notwithstanding any other provision herein, and to ensure the safety of students, faculty, staff and facilities, James Madison University reserves the right to approve or disapprove any contract employee that will work on JMU property. Disapproval by the University will solely apply to JMU property and should have no bearing on the Contractor's employment of an individual outside of James Madison University.
- N. INDEMNIFICATION: Contractor agrees to indemnify, defend and hold harmless the Commonwealth of Virginia, its officers, agents, and employees from any claims, damages and actions of any kind or nature, whether at law or in equity, arising from or caused by the use of any materials, goods, or equipment of any kind or nature furnished by the contractor/any services of any kind or nature furnished by the contractor, provided that such liability is not attributable to the sole negligence of the using agency or to failure of the using agency to use the materials, goods, or equipment in the manner already and permanently described by the contractor on the materials, goods or equipment delivered.
- O. ADDITIONAL GOODS AND SERVICES: The University may acquire other goods or services that the supplier provides than those specifically solicited. The University reserves the right, subject to mutual agreement, for the Contractor to provide additional goods and/or services under the same pricing, terms, and conditions and to make modifications or enhancements to the existing goods and services. Such additional goods and services may include other products, components, accessories, subsystems, or related services that are newly introduced during the term of this Agreement. Such additional goods and services will be provided to the University at favored nations pricing, terms, and conditions.
- P. ADVERTISING: In the event a contract is awarded for supplies, equipment, or services resulting from this proposal, no indication of such sales or services to James Madison University will be used in product literature or advertising without the express written consent of the University. The contractor shall not state in any of its advertising or product literature that James Madison University has purchased or uses any of its products or services, and the contractor shall not include James Madison University in any client list in advertising and promotional materials without the express written consent of the University.
- Q. ELECTRICAL EQUIPMENT STANDARDS: All equipment/material shall conform to the latest issue of all applicable standards as established by National Electrical Manufacturer's Association (NEMA), American National Standards Institute (ANSI), and Occupational Safety & Health Administration (OSHA). All equipment and material, for which there are OSHA standards, shall bear an appropriate label of approval for use intended from a Nationally Recognized Testing Laboratory (NRTL).
- R. FINAL INSPECTION: At the conclusion of the work, the contractor shall demonstrate to the authorized owner's representative that the work is fully operational and in compliance with

contract specifications and codes. Any deficiencies shall be promptly and permanently corrected by the contractor at the contractor's sole expense prior to final acceptance of the work.

- S. PRIME CONTRACTOR RESPONSIBILITIES: The contractor shall be responsible for completely supervising and directing the work under this contract and all subcontractors that he may utilize, using his best skill and attention. Subcontractors who perform work under this contract shall be responsible to the prime contractor. The contractor agrees that he is as fully responsible for the acts and omissions of his subcontractors and of persons employed by them as he is for the acts and omissions of his own employees.
- T. WORK SITE DAMAGES: Any damage to existing utilities, equipment or finished surfaces resulting from the performance of this contract shall be repaired to the Commonwealth's satisfaction at the contractor's expense.
- U. STANDARDS OF CONDUCT: The work site will be occupied by students and University Personnel during the times work is performed. Contractor and Contractor's personnel shall exercise a particularly high level of discipline, safety, and cooperation at all times while on the job site. The Contractor shall be responsible for controlling employee conduct, for assuring that its employees are not boisterous or rude, and assuring that they are not engaging in any destructive or criminal activity. The Contractor is also responsible for ensuring that its employees do not disturb papers on desks, or open desk drawers, cabinets, or briefcases, or use State phones, and the like, except as authorized.
- V. WARRANTY (COMMERICAL): The contractor agrees that the goods or services furnished under any award resulting from this solicitation shall be covered by the most favorable commercial warranties the contractor gives any customer for such goods or services and that the rights and remedies provided therein are in addition to and do not limit those available to the Commonwealth by any other clause of this solicitation. A copy of this warranty should be furnished with the proposal.
- W. KEYS: If the Contractor is given keys for this project, it is the Contractor's responsibility to return the keys when the contract is terminated, as well as for the safekeeping of the keys during the contract period. The Contractor shall not loan or duplicate the keys. In the event the Contractor loses the keys, they will be charged for the replacement of the keys and any locks which are rekeyed or replaced.
- X. CONTRACTOR/SUBCONTRACTOR LICENSE REQUIREMENT: By my signature on this solicitation, I certify that this firm/individual and subcontractor is properly licensed for providing the goods/services specified.

Contractor Name: \_\_\_\_\_ Subcontractor Name: \_\_\_\_\_

License # \_\_\_\_\_ Type \_\_\_\_\_

- Y. DELIVERY AND STORAGE: It shall be the responsibility of the contractor to make all arrangements for delivery, unloading, receiving and storing materials in the building during installation. The owner will not assume any responsibility for receiving these shipments. Contractor shall check with the owner and make necessary arrangements for security and storage space in the building during installation.

- Z. ASBESTOS: Whenever and wherever during the course of performing any work under this contract, the contractor discovers the presence of asbestos or suspects that asbestos is present, he shall stop the work immediately, secure the area, notify the building owner and await positive identification of the suspect material. During the downtime in such a case, the contractor shall not disturb any surrounding surfaces but shall protect the area with suitable dust covers. In the event the contractor is delayed due to the discovery of asbestos or suspected asbestos, then a mutually agreed extension of time to perform the work shall be allowed the contractor but without additional compensation due to the time extension.
- AA. PRIME CONTRACTOR RESPONSIBILITIES: The contractor shall be responsible for completely supervising and directing the work under this contract and all subcontractors that he may utilize, using his best skill and attention. Subcontractors who perform work under this contract shall be responsible to the prime contractor. The contractor agrees that he is as fully responsible for the acts and omissions of his subcontractors and of persons employed by them as he is for the acts and omissions of his own employees.
- BB. SUBCONTRACTS: No portion of the work shall be subcontracted without prior written consent of the purchasing agency. In the event that the contractor desires to subcontract some part of the work specified herein, the contractor shall furnish the purchasing agency the names, qualifications and experience of their proposed subcontractors. The contractor shall, however, remain fully liable and responsible for the work to be done by its subcontractor(s) and shall assure compliance with all requirements of the contract.
- CC. WORK ESTIMATES: Under this time and material contract, the contractor shall furnish the agency with a non-binding written estimate of the total costs to complete the work required. The estimate must include the labor category(ies), the contractor's hourly rates specified in the contract, and the total material cost. Material costs shall be billed at contractor's actual invoice costs (contractor shall furnish copies of all invoices for materials) or discount off the list price, whichever is specified in the contract. If the agency determines that the estimated price is not fair and reasonable, the agency has the right to ask the contractor to reevaluate the estimate. If the revised estimate is determined to be not fair and reasonable, the agency reserves the right to obtain additional quotes from other vendors. A work order will be issued to the contractor, as the authority to proceed with the work, which will incorporate the contractor's estimate and the terms and conditions of the contract. The contractor and his/her personnel shall log in with the designated contract administrator each day before and after work to confirm labor hours.
- DD. WORK SITE DAMAGES: Any damage to existing utilities, equipment or finished surfaces resulting from the performance of this contract shall be repaired to the Commonwealth's satisfaction at the contractor's expense.

## **IX. METHOD OF PAYMENT**

The contractor will be paid based on invoices submitted in accordance with the solicitation and any negotiations. James Madison University recognizes the importance of expediting the payment process for our vendors and suppliers; we request that our vendors and suppliers enroll in our bank's Comprehensive Payable options: either the Virtual Payables Virtual Card or the PayMode-X electronic deposit (ACH) to your bank account so that future payments are made electronically. Contractors signed up for the Virtual Payables process will receive the benefit of being paid Net 15. Additional information is available online at:

<http://www.jmu.edu/financeoffice/accounting-operations-disbursements/cash-investments/vendor-payment-methods.shtml>

## X. PRICING SCHEDULE

The offeror shall provide pricing for all products and services included in proposal indicating one-time and on-going costs. The resulting contract will be cooperative and pricing shall be inclusive for the attached Zone Map, of which JMU falls within Zone 2.

### Labor Rates

Ceiling Tile Installation	Regular Working Hours	Overtime Hours
Project manager	95.00	142.50
Lead Crew	95.00	142.50
Helper	50.00	75.00
Plaster Services	Regular Working Hours	Overtime Hours
Project manager	95.00	142.50
Lead Crew	95.00	142.50
Helper	50.00	75.00
Drywall services	Regular Working Hours	Overtime Hours
Project manager	95.00	142.50
Lead Crew	95.00	142.50
Helper	50.00	75.00

### Parts and Supplies

Materials/Parts	List Price	% Discount Off MSRP	University Price
(Fill in as needed)			
As Need it			

### Equipment Rentals

Type of Equipment	Price Breakdown
Lift	60' Articulating-4,298.83-monthly
Misc. Other	50" Rough Terrain Scissor lift-3254.04-monthly

**Other Pricing. Specify any associated charge card processing fees, if applicable, to be billed to the university.**

Other Charges or Fees	Amount
Charge Card Processing Fee	N/A
Misc. Other	N/A

## **XI. ATTACHMENTS**

Attachment A: Offeror Data Sheet

Attachment B: Small, Women, and Minority-owned Business (SWaM) Utilization Plan

Attachment C: Standard Contract Sample

Attachment D: Zone Map

Attachment E: SWaM Sub-contractor Reporting Template

Attachment F: The JMU [Design and Construction Guidelines](#) (as amended)

ATTACHMENT A

OFFEROR DATA SHEET

TO BE COMPLETED BY OFFEROR

- 1. QUALIFICATIONS OF OFFEROR: Offerors must have the capability and capacity in all respects to fully satisfy the contractual requirements.
- 2. YEARS IN BUSINESS: Indicate the length of time you have been in business providing these types of goods and services.

Years 21 Months 1

- 3. REFERENCES: Indicate below a listing of at least five (5) organizations, either commercial or governmental/educational, that your agency is servicing. Include the name and address of the person the purchasing agency has your permission to contact.

CLIENT	LENGTH OF SERVICE	ADDRESS	CONTACT PERSON/PHONE #
<u>VDOT-Fredericksburg-2019-Current</u>	<u>87 Deacon Rd</u>	<u>Fredericksburg, 22405</u>	<u>Noel Lemle-540-899-4210</u>
<u>Chesterfield County-2020-Current</u>	<u>9901 Lori Rd</u>	<u>Chesterfield, 23832</u>	<u>Earl Kirby-804-717-6395</u>
<u>Virginia Military Institute-2021-Current</u>	<u>320 Institute Hill</u>	<u>Lexington, 24450</u>	<u>John Harris-540-464-7848</u>
<u>Goochland County Schools-2020-Present</u>	<u>2938-I River Rd W</u>	<u>23063</u>	<u>Glenn Forbes-804-386-4015</u>
<u>Hanover County-2014-Present</u>	<u>Scottie Sauls</u>	<u>804-246-3806</u>	

- 4. List full names and addresses of Offeror and any branch offices which may be responsible for administering the contract.

Hristo Katrev

---

3006 Lincoln Ave

Richmond, Va, 23228

---



---

- 5. RELATIONSHIP WITH THE COMMONWEALTH OF VIRGINIA: Is any member of the firm an employee of the Commonwealth of Virginia who has a personal interest in this contract pursuant to the [CODE OF VIRGINIA](#), SECTION 2.2-3100 – 3131?

YES  NO

IF YES, EXPLAIN: \_\_\_\_\_

---



---



---

ATTACHMENT B

Small, Women and Minority-owned Businesses (SWaM) Utilization Plan

Offeror Name: The Crpentry and Pnting Experts, LLC Preparer Name: Hristo Katrev

Date: 07/15/2025

Is your firm a **Small Business Enterprise** certified by the Department of Small Business and Supplier Diversity (SBSD)? Yes X No       

If yes, certification number: 672999 Certification date: 12/16/2014

Is your firm a **Woman-owned Business Enterprise** certified by the Department of Small Business and Supplier Diversity (SBSD)? Yes        No       

If yes, certification number:                      Certification date:                     

Is your firm a **Minority-Owned Business Enterprise** certified by the Department of Small Business and Supplier Diversity (SBSD)? Yes        No       

If yes, certification number:                      Certification date:                     

Is your firm a **Micro Business** certified by the Department of Small Business and Supplier Diversity (SBSD)? Yes        No       

If yes, certification number:                      Certification date:                     

**Instructions:** *Populate the table below to show your firm's plans for utilization of small, women-owned and minority-owned business enterprises in the performance of the contract. Describe plans to utilize SWAMs businesses as part of joint ventures, partnerships, subcontractors, suppliers, etc.*

**Small Business:** "Small business " means a business, independently owned or operated by one or more persons who are citizens of the United States or non-citizens who are in full compliance with United States immigration law, which, together with affiliates, has 250 or fewer employees, or average annual gross receipts of \$10 million or less averaged over the previous three years.

**Woman-Owned Business Enterprise:** A business concern which is at least 51 percent owned by one or more women who are U.S. citizens or legal resident aliens, or in the case of a corporation, partnership or limited liability company or other entity, at least 51 percent of the equity ownership interest in which is owned by one or more women, and whose management and daily business operations are controlled by one or more of such individuals. **For purposes of the SWAM Program, all certified women-owned businesses are also a small business enterprise.**

**Minority-Owned Business Enterprise:** A business concern which is at least 51 percent owned by one or more minorities or in the case of a corporation, partnership or limited liability company or other entity, at least 51 percent of the equity ownership interest in which is owned by one or more minorities and whose management and daily business operations are controlled by one or more of such individuals. **For purposes of the SWAM Program, all certified minority-owned businesses are also a small business enterprise.**

**Micro Business** is a certified Small Business under the SWaM Program and has no more than twenty-five (25) employees AND no more than \$3 million in average annual revenue over the three-year period prior to their certification.

**All small, women, and minority owned businesses must be certified by the Commonwealth of Virginia Department of Small Business and Supplier Diversity (SBSD) to be counted in the SWAM program. Certification applications are available through SBSB at 800-223-0671 in Virginia, 804-786-6585 outside Virginia, or online at <http://www.sbsd.virginia.gov/> (Customer Service).**

***RETURN OF THIS PAGE IS REQUIRED***

**ATTACHMENT B (CNT'D)**  
**Small, Women and Minority-owned Businesses (SWaM) Utilization Plan**

Procurement Name and Number: \_\_\_\_\_

Date Form Completed: \_\_\_\_\_

Listing of Sub-Contractors, to include, Small, Woman Owned and Minority Owned Businesses  
 for this Proposal and Subsequent Contract

Offeror / Proposer:

The Carpentry and Painting experts, LLC  
 Firm

3006Lincoln Ave, Richmond, VA, 23228  
 Address

Hristo Katrev-804-997-9703  
 Contact Person/No.

Sub-Contractor's Name and Address	Contact Person & Phone Number	SBSD Certification Number	Services or Materials Provided	Total Subcontractor Contract Amount (to include change orders)	Total Dollars Paid Subcontractor to date (to be submitted with request for payment from JMU)
N/A					

*(Form shall be submitted with proposal and if awarded, a SWaM Sub-contractor Reporting Form shall be submitted to [swamreporting@jmu.edu](mailto:swamreporting@jmu.edu))*

**RETURN OF THIS PAGE IS REQUIRED**

ATTACHMENT C



COMMONWEALTH OF VIRGINIA
STANDARD CONTRACT

Contract No. \_\_\_\_\_

This contract entered into this \_\_\_\_\_ day of \_\_\_\_\_ 20\_\_\_\_, by \_\_\_\_\_ hereinafter called the "Contractor" and Commonwealth of Virginia, James Madison University called the "Purchasing Agency".

WITNESSETH that the Contractor and the Purchasing Agency, in consideration of the mutual covenants, promises and agreements herein contained, agree as follows:

SCOPE OF CONTRACT: The Contractor shall provide the services to the Purchasing Agency as set forth in the Contract Documents.

PERIOD OF PERFORMANCE: From \_\_\_\_\_ through \_\_\_\_\_

The contract documents shall consist of:

- (1) This signed form;
(2) The following portions of the Request for Proposals dated \_\_\_\_\_:
(a) The Statement of Needs,
(b) The General Terms and Conditions,
(c) The Special Terms and Conditions together with any negotiated modifications of those Special Conditions;
(d) List each addendum that may be issued
(3) The Contractor's Proposal dated \_\_\_\_\_ and the following negotiated modification to the Proposal, all of which documents are incorporated herein.
(a) Negotiations summary dated \_\_\_\_\_.

IN WITNESS WHEREOF, the parties have caused this Contract to be duly executed intending to be bound thereby.

CONTRACTOR:

PURCHASING AGENCY:

By: \_\_\_\_\_ (Signature)

By: \_\_\_\_\_ (Signature)

\_\_\_\_\_  
(Printed Name)

\_\_\_\_\_  
(Printed Name)

Title: \_\_\_\_\_

Title: \_\_\_\_\_

# ATTACHMENT D

## Zone Map



### Virginia Association of State College & University Purchasing Professionals (VASCUPP)

#### List of member institutions by zones

- |  |  |   |
|--|--|---|
| <b><u>Zone 1</u></b><br>George Mason University (Fairfax)              | <b><u>Zone 2</u></b><br>James Madison University (Harrisonburg)  | <b><u>Zone 3</u></b><br>University of Virginia (Charlottesville)  |
| <b><u>Zone 4</u></b><br>University of Mary Washington (Fredericksburg) | <b><u>Zone 5</u></b><br>Christopher Newport University (Newport News)<br>College of William and Mary (Williamsburg)<br>Norfolk State University (Norfolk)<br>Old Dominion University (Norfolk) | <b><u>Zone 6</u></b><br>Virginia Commonwealth University (Richmond)<br>Virginia State University (Petersburg) |
| <b><u>Zone 7</u></b><br>Longwood University (Farmville)                | <b><u>Zone 8</u></b><br>Virginia Military Institute (Lexington)<br>Virginia Tech (Blacksburg)<br>Radford University (Radford)  | <b><u>Zone 9</u></b><br>University of Virginia - Wise (Wise)  |

***The Carpentry &  
Painting Experts***

*"Let us impress you!"*



Hristo Katre  
The Carpentry and Painting Experts, LLC  
3006 Lincoln Ave, Richmond, VA 23228

**B. DESCRIBE STATEMENTS: address the following statements within proposal.**

- 1. Describe your approach and ability to provide excellent customer service throughout the term of the contract, to include mobilization of the contractor's management and work staff to meet the needs stated herein. Include how you will provide excellent customer service on fast turn-around projects to include mobilization of a crew if your firm is not in close proximity to the County.**

Our team is dedicated to providing excellent and professional services, with a great emphasis on punctuality. We are known for our excellent craftsmanship. All of our field employees are well trained craftsmen with sufficient experience in their respective trades. Our company culture has brought to live a team that is extremely careful and respectful when it comes to working in occupied spaces.

We pride ourselves in always being on time and presenting our company and our customers in the most professional manner. We have been known to make impossible deadlines, by being creative and also using multiple shift crews to achieve the needed goal on fast turn-around projects. We have a great team of professionals who are always available to do whatever and whenever you need us to do. We can turn projects on the most ambitious schedules, even if that requires working multiple shifts and sourcing resources in the last minute. Our philosophy is that every problem has a solution and when in need, our teams always create a solution when faced with a problem. Renovation projects often present unexpected situations, but we pride ourselves in always being able to present a quick and effective resolution to our customers in a timely fashion without compromise to quality.

- 2. Describe your firm's background, size, and history as it may be relevant to On-Call GC Services, with an emphasis on general construction work provided on an on-call or task order basis.**

We have over 20 years of experience in working on term contracts with commercial, state, government agencies and Universities. All of our employees are well trained craftsmen with sufficient experience in their respective trades. We have been rated by our customers in numerous websites, thank you letters and have A+ BBB rating. Our company is also a Class A licensed contractor in Virginia, and we are licensed Lead Paint Abatement contractor.

We have systems in place including proprietary software to track and project manage multiple projects simultaneously. Our team is proficient in all facets of construction and all of

our superintendents and key personal are selected based on their problem-solving abilities and consistently responsible behavior. CPE takes pride in mobility and data access provided for all of our employees, which makes them very well equipped to the satisfaction of our customers. We self-perform a number of trades with in-house employees. We also have a vast and comprehensive group of subcontractors, with which we work on permanent basis.

- 3. Provide an organizational chart indicating which individuals or positions will have knowledge of the contract with the University and the degree which each person would be responsible to the University account. Include names of project managers and supervisors.***

Please see attached.

- 4. Describe the experience your firm has with provisions of similar services to comparable institutions. These may be term contracts or spot purchases.***

We have been in business since 2004. We are experienced in providing an ongoing on-call General Contractor Services for many state and government contracts. We are currently contracted with Department of Military Affairs/since 2015. We are also contracted on a renewable term contract for General Contractor Services with the following agencies: George Mason University, Virginia Department of Transportation – Fredericksburg district, Department of Corrections, Virginia Department of Aviation, Spotsylvania County Schools, Goochland County, Virginia Tech. Having this experience with state/government contracts helps us and our employees to be familiar with the work requirements for state agencies including: invoicing requirements, work order compliance, payment structure and payment methods. We've also provided GC services for Virginia Commonwealth University, Richard Bland College, Virginia Department of State Police, Albemarle County Schools.

- 5. Provide a statement that indicates whether your firm has been subject to OSHA inspections by State and/or Federal agencies and the results, including citations, if any.***

N/A

6. ***Provide information regarding any contract that an institution, agency, or company that chose not to renew with your firm in the last five years, including the reason the contract was not renewed.***

N/A

## **B. SPECIFIC PROPOSAL INSTRUCTIONS**

### ***2. Plan and methodology for providing the goods/services Statement of Needs of this Request for Proposal.***

- Once a request for service is received we would schedule a time for inspection/estimate within 48 hours of notification.
- Written proposal will be submitted where applicable the within 5 days of the site visit or within a reasonable time there after based on materials pricing and specificity of the job.
- Once a proposal is approved a start day and time will be scheduled and supervisor will be assigned to the project.
- Contractor will always assign the appropriate number of employees needed to complete the project within the prospected timeframe by JMU.
- Each of our projects will have one assigned employee, who is the onsite point of contact and in charge of the work process in the field. For single trade projects the working foreman may also be designated as the superintendent, who has the ability to direct the work, follow the safety plan and ensure on time smooth completion of the work. This person will always be aware of the entire scope of the project and available on site. Project managers will be the administrative point of contact for each job. There will be assigned project manager for each project, although they usually manage more than one project at a time.
- Once at jobsite all employees will follow instructions specified depending on the requirements and specs provided by contract officer.
- All employees are expected to behave professionally and look clean and presentable, while on jobsite. They will wear name tags as requested.
- All employees will be held accountable for maintaining the order and cleanliness of the jobsite on a daily basis.
- All employees will be held to OSHA safety regulations while at the premises, and utilize necessary protective gear supplied by the contractor

- Employees will have on them or in their van all necessary and adequate tools and equipment for each job.
- The work being performed will be done to meet and exceed industry standards.
- The contractor will check in with university's designated representative daily while project lasts.
- Once project (job) is completed the contractor will submit any receipts for rental equipment and materials along with an invoice. All invoices will be submitted no later than 30 days after job completion.
- Payments will be accepted either by check or credit card.

***3. A written narrative statement to include, but not be limited to, the expertise, qualifications, and experience of the firm and resumes of specific personnel to be assigned to perform the work.***

Our company has a number of superintendents and project managers, which will be making sure all employees will behave in a professional manner, treating all faculty staff and students with respect, and assuring that employees are not engaging in any destructive or criminal activities. Our employees are known for their punctuality and professionalism while on job site. Each project has an assigned project manager who is the point of contact with the customer. The project manager is in charge of making sure all submittals, change order requests, schedules are submitted properly and within the time frame that the deadlines allow for. The project manager is also in charge of ensuring that the project schedule is being followed and the deadlines are met. In the case that this is not happening as expected project manager along with the owner of the company will create a solution to get back on track. The same employees will be assigned on a repeated basis to perform the work at the campus in order to increase efficiency in communication with the Facilities Manager.

Please, see attached personnel resumes.

# Organizational Chart

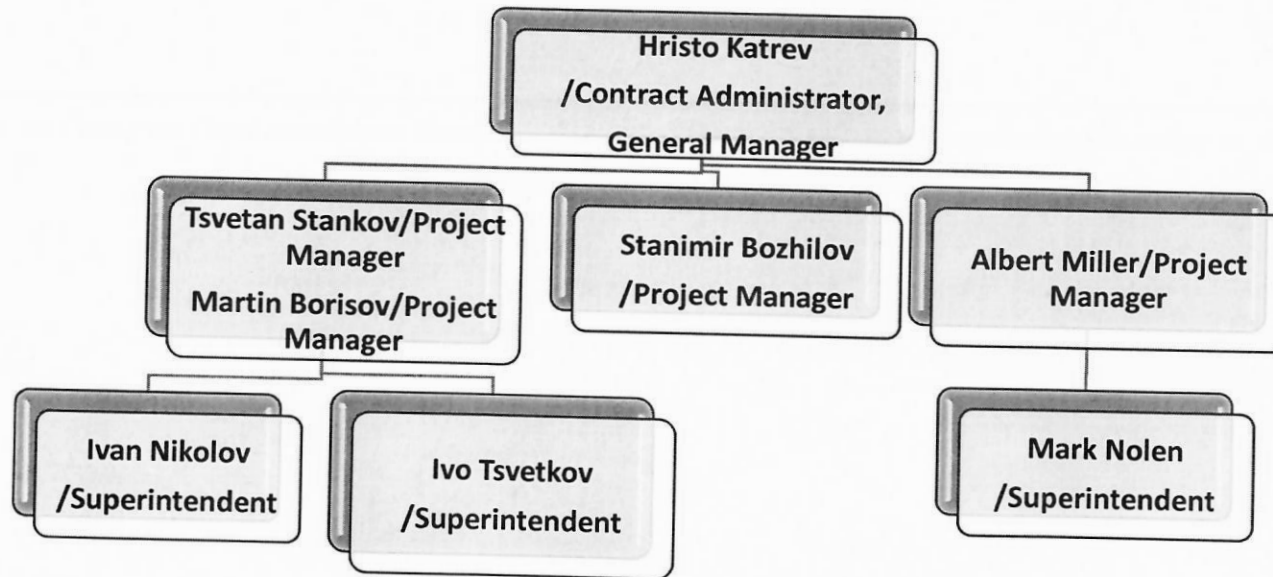

# **Albert Miller**

**Project Manager/**

**Commercial and Government Contracts**



## *Experience:*

With CPE CONTRACTORS LLC since 2019

- ❖ Supervise commercial projects of various size
- ❖ Possessing strong knowledge of all aspects of the construction industry
- ❖ Managing wide variety of subcontractors and suppliers, and overall job site
- ❖ More than 35 years of field experience

## *Education:*

- Bradley University  
Peoria,  
Construction  
Management  
1984

## *Key Projects:*

1. Goochland County, Registrar Office,  
Addition to main entrance & interior renovation  
1800 Sandy Hook Rd, Goochland, VA 23063  
Project value: \$363,100.00
2. Albemarle County, Albemarle County High School  
Shop Renovation  
5941 Rockfish Gap Turnpike, Crozet, VA 22932  
Project Value: \$233,365.00
3. York County, Bruton High School  
Create learning commons & renovate school of the  
arts restrooms  
120 Alexander Hamilton Boulevard, Yorktown, VA  
Project Value: \$695,000

## *Certifications:*

OSHA 10  
First Aid



# **Tsvetan Stankov**

**Project Manager/**

**Commercial and Government Contracts**

## ***Experience:***

With CPE CONTRACTORS LLC since 2015

- ❖ Supervise commercial projects of various size
- ❖ Possessing strong knowledge of all aspects of the construction industry
- ❖ Maintain coordination with project Owners, architects and engineers
- ❖ Supervise workforce and overall job site
- ❖ Problem solving skills

## ***Key Projects:***

1. Complete Dental Office Renovation,  
Stafford and Associates  
3603 Grove Ave, Richmond, VA 23221  
Project value: \$375,703.00
2. VA Tech, Johnson Hall Restroom Renovation –  
Phase 1  
300 Turner Street, Blacksburg, VA 24061  
Project Value: \$613,900.00
3. VA Tech, Newman Hall Toilet/Shower Room  
Renovation – Phase 2  
200 Kent Street, Blacksburg, Virginia 24061  
Project Value: \$218,197.69
4. Spotsylvania county Public Schools  
8020 River Stone Drive, Fredericksburg, 22407  
Multiple locations  
Contact: Barry Dickinson, 540-841-8055  
Value 2021-2022- Over 700k

## ***Education:***

- Technical high school, Bulgaria-2006

## ***Certification:***

- OSHA 10



## **Ivan Nikolov**

**Superintendent/**

**Commercial and Government Contracts**

### ***Experience:***

With CPE CONTRACTORS LLC since 2018

- ❖ Supervise commercial projects of various size, including renovation projects at VCU
- ❖ Possessing strong knowledge of all aspects of the construction industry
- ❖ Managing 10 employee and wide variety of subcontractors, and overall job site
- ❖ 4 years of field experience

### ***Key Projects:***

1. AHS Science Classroom 246 Renovation, Albemarle County Public Schools  
2775 Hydraulic Rd, Charlottesville, VA 22901  
Project value: \$96,382.13
2. VCU, Full room renovation for 6-010, 6-012, 6-025, & 6-054, Sanger Hall  
1101 East Marshall Street, Richmond, VA 23298  
Project value: \$96,111.88
3. Spotsylvania County Public Schools  
8020 River Stone Drive  
Multiple Locations  
Contact; Barry Dickinson, 540-841-8055

### ***Education:***

- Technical High School, Electric Industrial, 1993



# Stanimir Bozhilov

Project Manager/

Commercial Painting Division

**The Carpentry & Painting Experts**  
"Let us impress you!" 

## Experience:

With CPE CONTRACTORS LLC since 2019

- ❖ Supervise commercial painting projects of various size
- ❖ Possessing strong knowledge of all aspects of the construction industry
- ❖ Managing 10 employee and wide variety of subcontractors, and overall job site
- ❖ More than 10 years of field experience

## Key Projects:

1. Albemarle County Public Schools,  
Interior Painting, Summer prep  
Contact: Sharon Woods, 434-466-2380  
Project value: \$85,000.00
2. Dinwiddie County, Namozine Volunteer Fire  
Department, Interior Painting of Apparatus bay  
3913 Pelham Ave, Petersburg, VA 23803  
Contact: Chuck Lewis, 804-720-3291  
Project value: \$22,100.00
3. City of Lynchburg, Exterior Painting of Public Safety  
Building  
900 Church Street, Lynchburg, VA 24504  
Contact: Randy Dalton, 434-455-4407  
Project value: \$23,895.00
4. Goochland County Schools,  
Multiple Locations  
Contact: Todd Steeley, 804-386-4015

## Education:

- Technical High School
- College in Economics

## Certifications:

OSHA 30

Lead Renovator



# **Yanni Anastasiou**

**Project Manager/**

**Commercial Painting Division**

## ***Experience:***

With CPE CONTRACTORS LLC since 2019

- ❖ Supervise commercial painting projects of various size
- ❖ Possessing strong knowledge of all aspects of the construction industry
- ❖ Managing 10 employee and wide variety of subcontractors, and overall job site
- ❖ More than 15 years of field experience

## ***Key Projects:***

1. Virginia Commonwealth University  
Interior Painting, Summer prep of Dorms  
Contact: Tenecia Dixon, 804-828-8843  
Term Contract for Painting Services
2. James Madison University  
Painting Services  
Contact: Brian Owens, 540-568-6870  
Term Contract for Painting Services
3. Hanover County,  
Painting Services for County Schools, summer prep  
Liberty Middle School  
Contact: Edward Buzzelli, (804) 339-8819  
Project value: \$181,206.00
4. Department of Correction  
Flooring, Concrete, Painting  
Multiple Location  
Contact: David Baker, 434-660-9617

## ***Education:***

- Richland College,  
Texas

## ***Certifications:***

OSHA 10

Lead Renovator



# **Mark Nolen**

**Superintendent/**

**Commercial and Government Contracts**

## *Experience:*

With CPE CONTRACTORS LLC since 2017

- ❖ Master Carpenter focus in high end interior and exterior projects
- ❖ Supervise commercial projects of various size, including renovation projects at VCU
- ❖ Possessing strong knowledge of all aspects of the construction industry
- ❖ Safety and quality control for job site
- ❖ Over 30 years of construction experience and supervision

## *Key Projects:*

1. VCU, Renovation at Shafer Dining Center  
810 Cathedral Place, Richmond, VA 23220
2. VCU, Interior Renovation for Kearney House  
921 West Franklin Street, Richmond, VA 23220
3. Glen Alden Warehouse-VDOT  
5325 Glen Alden Drive, Richmond, VA, 23231
4. Henrico County  
Godwin High School  
2101 Pump Road, Richmond, VA, 23238

**The Carpentry &  
Painting Experts**  
"Let us impress you!" 

## *Education:*

- Technical High School Diploma



# Request for Proposal

## **RFP# ADL-1236**

**Ceiling Tile Installation, Drywall and Plastering  
Services**

**June 03, 2025**



**REQUEST FOR PROPOSAL**  
**RFP# ADL-1236**

**Issue Date:** June 03, 2025  
**Title:** Ceiling Tile installation, Drywall and Plaster Services  
**Issuing Agency:** Commonwealth of Virginia  
James Madison University  
Procurement Services MSC 5720  
752 Ott Street, Wine Price Building  
First Floor, Suite 1023  
Harrisonburg, VA 22807

**Period of Contract: From Date of Award Through One Year (Renewable)**

**Sealed Proposals Will Be Received Until 2:00 PM on July 15, 2025 for Furnishing The Services Described Herein. (See Special Terms & Conditions “D. Late Proposals”)**

*SEALED PROPOSALS MAY BE MAILED, EXPRESS MAILED, SUBMITTED IN eVA, OR HAND DELIVERED DIRECTLY TO THE ISSUING AGENCY SHOWN ABOVE.*

All Inquiries For Information And Clarification Should Be Directed To: Aaron Largent, Buyer Senior, Procurement Services, Largenad@jmu.edu; 540-568-4160; (Fax) 540-568-7935 not later than five business days before the proposal closing date.

**NOTE: THE SIGNED PROPOSAL AND ALL ATTACHMENTS SHALL BE RETURNED.**

In compliance with this Request for Proposal and to all the conditions imposed herein, the undersigned offers and agrees to furnish the goods/services in accordance with the attached signed proposal or as mutually agreed upon by subsequent negotiation.

Name and Address of Firm:

\_\_\_\_\_  
\_\_\_\_\_  
\_\_\_\_\_

By: \_\_\_\_\_  
*(Signature)*

Name: \_\_\_\_\_  
*(Please Print)*

Date: \_\_\_\_\_

Title: \_\_\_\_\_

Web Address: \_\_\_\_\_

Phone: \_\_\_\_\_

Email: \_\_\_\_\_

Fax #: \_\_\_\_\_

ACKNOWLEDGE RECEIPT OF ADDENDUM: #1 \_\_\_\_\_ #2 \_\_\_\_\_ #3 \_\_\_\_\_ #4 \_\_\_\_\_ #5 \_\_\_\_\_ (please initial)

SMALL, WOMAN OR MINORITY OWNED BUSINESS:

YES;  NO; *IF YES* ⇒⇒  SMALL;  WOMAN;  MINORITY ***IF MINORITY:***  AA;  HA;  AsA;  NW;  Micro

**Note: This public body does not discriminate against faith-based organizations in accordance with the Code of Virginia, § 2.2-4343.1 or against an offeror because of race, religion, color, sex, national origin, age, disability, or any other basis prohibited by state law relating to discrimination in employment.**

# ***REQUEST FOR PROPOSAL***

*RFP # ADL-1236*

## ***TABLE OF CONTENTS***

I.	PURPOSE .....	Page	1
II.	BACKGROUND .....	Page	1
III.	SMALL, WOMAN-OWNED, AND MINORITY PARTICIPATION .....	Page	1
IV.	STATEMENT OF NEEDS .....	Page	1-4
V.	PROPOSAL PREPARATION AND SUBMISSION .....	Page	4-7
VI.	EVALUATION AND AWARD CRITERIA .....	Page	7-8
VII.	GENERAL TERMS AND CONDITIONS .....	Page	8-15
VIII.	SPECIAL TERMS AND CONDITIONS .....	Page	15-21
IX.	METHOD OF PAYMENT .....	Page	21
X.	PRICING SCHEDULE .....	Page	22
XI.	ATTACHMENTS .....	Page	23-28
	A. Offeror Data Sheet		
	B. SWaM Utilization Plan		
	C. Sample of Standard Contract		
	D. Zone Map		
	E. SWaM Standard Reporting Template		
	F. The JMU <a href="#">Design and Construction Guidelines</a> (as amended)		

## **I. PURPOSE**

The purpose of this Request for Proposal (RFP) is to solicit sealed proposals from qualified sources to enter into a contract to provide Ceiling Tile Installation, Drywall and Plastering services for James Madison University (JMU), an agency of the Commonwealth of Virginia. Initial contract shall be for one (1) year with an option to renew for Four (4) additional one-year periods.

## **II. BACKGROUND**

James Madison University (JMU) is a comprehensive public institution in Harrisonburg, Virginia, with an enrollment of approximately 22,000 students and approximately 4,000 faculty and staff. There are over 600 individual departments on campus that support seven (7) academic divisions. The University offers over 120 majors, minors, and concentrations. Further information about the University can be found at the following website: [www.jmu.edu](http://www.jmu.edu).

James Madison University spends on average around \$200,000 annually on ceiling tile, drywall, and plastering services. As the University continues to grow, the need for these services will increase as well.

## **III. SMALL, WOMAN-OWNED AND MINORITY PARTICIPATION**

It is the policy of the Commonwealth of Virginia to contribute to the establishment, preservation, and strengthening of small businesses and businesses owned by women and minorities, and to encourage their participation in State procurement activities. The Commonwealth encourages contractors to provide for the participation of small businesses and businesses owned by women and minorities through partnerships, joint ventures, subcontracts, and other contractual opportunities. Attachment B contains information on reporting spend data with subcontractors.

## **IV. STATEMENT OF NEEDS**

### **A. Scope of Work**

The University has identified three (3) areas where products and services are required:

- 1. Ceiling Tile Installation**
- 2. Drywall Services**
- 3. Plastering Services**

Offerors interested in this solicitation may choose one (1), two (2) or all of the areas under the Statement of Needs section of this RFP to respond to.

The selected contractor(s) shall provide all labor, materials, equipment, transportation, supervision, and incidentals necessary to perform the following services on an as needed basis:

Because this contract shall be multiple awards, projects will be distributed amongst the contractors in the following manner. The University may select any one of the contracted vendors if a project is valued at less than \$200,000. If the project is valued at \$200,000 or more, then all contractors under this contract will be contacted, a site visit shall be held, and a proposal will be requested from each for that particular project. The contractor will

then be selected based on those proposals. No single project under this contract shall exceed \$1,000,000.

### **1. Ceiling Tile Installation**

- Installation of new ceiling tiles in various building types, but not limited to, classrooms, administrative offices, residence halls, and common areas. To include acoustical and decorative ceiling tiles.
- Installation of ceiling tile grid.
- Removal and replacement of damaged or outdated ceiling tiles.

### **2. Drywall Services**

- Installation of new drywall in interior spaces for renovation.
- Repair and removal of existing drywall due to damage, wear, or modifications.
- Taping, sanding, finishing, and preparation for painting.

### **3. Plastering Services**

- Application and repair of plaster finishes on walls and ceilings.
- Restoration of historic or decorative plaster in designated campus buildings as needed.
- Surface preparation, patching, and final finishing.

## **B. Service Requirements**

1. Work shall be performed on an as-needed, on-call basis, with varying project sizes and scopes. There is no guarantee of number or dollar value of project orders.
2. Response time shall occur within 48 hours of initial call. Response shall include quote and estimated time of completion.
3. All services must comply with applicable Virginia building codes, safety standards, and campus guidelines.
4. All project site workspaces shall be maintained in a clean orderly condition.
5. Contractor(s) must be available during regular business hours and occasionally after-hours or weekends for emergency or scheduled projects.
6. Contractor shall obtain a University issued purchase order prior to the commencement of any work.
7. Contractor shall permit the University, its agents, any public authority and their representatives' access to the work area for inspection. All work is subject to final approval by an authorized representative of the University upon completion. The Selected Firm will demonstrate to the University's CA or designee that the work is in compliance with all applicable codes, regulations, project drawings, and specifications for any work resulting from this assessment. Any deficiencies will be promptly corrected by the Selected Firm at its own expense prior to final acceptance of the work.

8. Contractor will be certified by the manufacturer or have established experience on all equipment and supplies for which the Selected Firms will provide or install. The Selected Firm will provide documentation for manufacturer certification and/or references (for previous customers with similar equipment) upon request by the end-using department.
9. All material supplied shall be institutional, industrial, and/or commercial grade, whichever is more stringent, in accordance with the standards of the industry for institutional and/or industrial construction and maintenance in compliance with the JMU Design and Construction Guidelines, see [https://www.jmu.edu/facmgt/fm\\_resources/guidelines/jmu-design-construction-guidelines.pdf](https://www.jmu.edu/facmgt/fm_resources/guidelines/jmu-design-construction-guidelines.pdf)
10. Contractor shall ensure all employees of the Selected Firms are fully trained to perform the services required, including, but not limited to, the handling and disposal of materials in a manner complying with OSHA and EPA standards.
11. All Selected Firm(s) will deliver in-stock product in accordance with delivery expectations of the end-user. Delivery time on any non-stock products will be detailed to the end-user prior to order placement.
12. Contractor shall break down all quotes and invoices in accordance with pricing provided in the PRICING SCHEDULE so as to verify pricing against the contract. The University will not issue a purchase order until an itemized quote is provided.
13. Contractor shall plan its work with the understanding that the University's Housing Division regular working hours are Monday through Friday, 7:30 a.m. until 4:00 p.m., except established holidays observed by the University, unless otherwise approved by an authorized university representative.
14. Contractor shall be required to work under the same conditions as does the University's Housing maintenance employees. This includes, but is not limited to, vehicle parking arranged through the University's Department of Parking and Transportation, complying with all building and safety codes, and scheduling work around the University's class schedules, special events, and holidays.
15. The University's CA or designee must approve all materials/products to be utilized prior to installation.
16. The Selected Firm is responsible for supervising and directing the work of its employees, as well as any subcontractors that may be utilized, by providing the firms best skills and sound judgment. No portion of any work will be subcontracted without prior written consent of the University. Subcontractors which perform work under any Agreement resulting from this RFP will be responsible to the prime contractor. The Selected Firm agrees that it is fully responsible for the acts and omissions of its subcontractors and of persons employed by the subcontractors, as it is for the acts and omissions of its own employees.

**C. Contractor shall provide the following in order for the proposal to be considered a complete response.**

1. Provide the University with labor charges for regular business hours as well as overtime/weekend/emergency hours on the PRICING SCHEDULE.

2. Provide sample quote and invoice. Samples should include how line items contain detailed quantities ordered, individual item cost, and extended total pricing.
3. For additional information needed to complete the proposal, please refer to the Specific Proposal Instructions (Section V Proposal Preparation and Submission; B – Specific Proposal Instructions, Q 1-7/ Pg. 7). **Questions 1-7 must be answered in their entirety for submissions to be considered complete.**

## V. PROPOSAL PREPARATION AND SUBMISSION

### A. GENERAL INSTRUCTIONS

**To ensure timely and adequate consideration of your proposal, offerors are to limit all contact, whether verbal or written, pertaining to this RFP to the James Madison University Procurement Office for the duration of this Proposal process. Failure to do so may jeopardize further consideration of Offeror's proposal.**

**ELECTRONIC OR PAPER SUBMISSIONS MAY BE ACCEPTED FOR THIS PROPOSAL. INSTRUCTIONS BELOW FOR OFFEROR'S CHOSEN METHOD (A. ELECTRONIC SUBMISSION or B. PAPER RESPONSE).**

1. RFP Response: In order to be considered for selection, the **Offeror shall submit a complete response to this RFP**; and shall submit to the issuing Purchasing Agency:

- a. **ELECTRONIC SUBMISSION:**

- i. ELECTRONIC RESPONSES SUBMITTED THROUGH eVA WILL BE ACCEPTED. **Emailed responses will not be accepted.** Please see below, "eVA Procurement Website and Registration" for additional information on registration. It is the responsibility of the Supplier to ensure their proposal and all required documentation is properly completed, readable, and uploaded to eVA. Suppliers should allow sufficient time to account for any technical difficulties they may encounter during online submission or uploading of the documents. In the event of any technical difficulties, Suppliers shall contact the eVA Customer Care Center at 1-866-289-7367 or via email at [eVACustomerCare@DGS.virginia.gov](mailto:eVACustomerCare@DGS.virginia.gov).
- ii. eVA Procurement Website and Registration The Commonwealth's procurement portal, eVA, located at <http://www.eva.virginia.gov>, provides information about Commonwealth solicitations and awards. Suppliers shall be registered in eVA in order submit a proposal to this RFP. To register with eVA, select "Register Now" on the eVA website homepage, <http://www.eva.virginia.gov>. For registration instructions and assistance, as well as instructions on how to submit proposals and accept orders please select "I Sell to Virginia". Suppliers are encouraged to check this site on a regular basis and, in particular, prior to submission of proposals to identify any amendments to the RFP that may have been issued.
- iii. Electronic Responses submitted through eVA shall be in WORD format or searchable PDF of the entire proposal, INCLUDING ALL ATTACHMENTS.

PDFs must be submitted in an unlocked format. Any proprietary information should be clearly marked in accordance with Section V.4.f below.

b. **PAPER SUBMISSIONS:**

- i. **One (1) original and one (1) copies** of the entire proposal, INCLUDING ALL ATTACHMENTS. Any proprietary information should be clearly marked in accordance with V.4.e. below.
  - ii. **One (1) electronic copy in WORD format or searchable PDF (CD or flash drive)** of the entire proposal, INCLUDING ALL ATTACHMENTS. Any proprietary information should be clearly marked in accordance with V.4.f below.
  - iii. Each copy of the proposal should be bound or contained in a single volume where practical. All documentation submitted with the proposal should be contained in that single volume.
  - iv. See additional information in Section VIII.C, *IDENIFICATION OF PROPSAL ENVELOPE*.
2. Should the proposal contain **proprietary information, provide one (1) redacted copy of the proposal** and all attachments with **proprietary portions removed or blacked out**. This copy should be clearly marked "*Redacted Copy*" on the front cover. The classification of an entire proposal document, line-item prices, and/or total proposal prices as proprietary or trade secrets is not acceptable. JMU shall not be responsible for the Contractor's failure to exclude proprietary information from this redacted copy.

No other distribution of the proposal shall be made by the Offeror.

3. The version of the solicitation issued by JMU Procurement Services, as amended by an addenda, is the mandatory controlling version of the document. Any modification of, or additions to, the solicitation by the Offeror shall not modify the official version of the solicitation issued by JMU Procurement services unless accepted in writing by the University. Such modifications or additions to the solicitation by the Offeror may be cause for rejection of the proposal; however, JMU reserves the right to decide, on a case-by-case basis in its sole discretion, whether to reject such a proposal. If the modification or additions are not identified until after the award of the contract, the controlling version of the solicitation document shall still be the official state form issued by Procurement Services.
4. Proposal Preparation
- a. Proposals shall be signed by an authorized representative of the Offeror. All information requested should be submitted. Failure to submit all information requested may result in the purchasing agency requiring prompt submissions of missing information and/or giving a lowered evaluation of the proposal. Proposals which are substantially incomplete or lack key information may be rejected by the purchasing agency. Mandatory requirements are those required by law or regulation or are such that they cannot be waived and are not subject to negotiation.

- b. Proposals shall be prepared simply and economically, providing a straightforward, concise description of capabilities to satisfy the requirements of the RFP. Emphasis should be placed on completeness and clarity of content.
  - c. Proposals should be organized in the order in which the requirements are presented in the RFP. All pages of the proposal should be numbered. Each paragraph in the proposal should reference the paragraph number of the corresponding section of the RFP. It is also helpful to cite the paragraph number, sub letter, and repeat the text of the requirement as it appears in the RFP. If a response covers more than one page, the paragraph number and sub letter should be repeated at the top of the next page. The proposal should contain a table of contents which cross references the RFP requirements. Information which the offeror desires to present that does not fall within any of the requirements of the RFP should be inserted at the appropriate place or be attached at the end of the proposal and designated as additional material. Proposals that are not organized in this manner risk elimination from consideration if the evaluators are unable to find where the RFP requirements are specifically addressed.
  - d. As used in this RFP, the terms “must”, “shall”, “should” and “may” identify the criticality of requirements. “Must” and “shall” identify requirements whose absence will have a major negative impact on the suitability of the proposed solution. Items labeled as “should” or “may” are highly desirable, although their absence will not have a large impact and would be useful, but are not necessary. Depending on the overall response to the RFP, some individual “must” and “shall” items may not be fully satisfied, but it is the intent to satisfy most, if not all, “must” and “shall” requirements. The inability of an offeror to satisfy a “must” or “shall” requirement does not automatically remove that offeror from consideration; however, it may seriously affect the overall rating of the offeror’ proposal.
  - e. Each copy of the proposal should be bound or contained in a single volume where practical. All documentation submitted with the proposal should be contained in that single volume.
  - f. Ownership of all data, materials and documentation originated and prepared for the State pursuant to the RFP shall belong exclusively to the State and be subject to public inspection in accordance with the Virginia Freedom of Information Act. Trade secrets or proprietary information submitted by the offeror shall not be subject to public disclosure under the Virginia Freedom of Information Act; however, the offeror must invoke the protection of Section 2.2-4342F of the Code of Virginia, in writing, either before or at the time the data is submitted. **The written notice must specifically identify the data or materials to be protected and state the reasons why protection is necessary. The proprietary or trade secret materials submitted must be identified by some distinct method such as highlighting or underlining and must indicate only the specific words, figures, or paragraphs that constitute trade secret or proprietary information. The classification of an entire proposal document, line-item prices and/or total proposal prices as proprietary or trade secrets is not acceptable. Marking an entire proposal as confidential or attempts to prevent disclosure of pricing information by designating it as confidential, proprietary or trade secret will be ignored.**
5. Oral Presentation: Offerors who submit a proposal in response to this RFP may be required to give an oral presentation of their proposal to James Madison University. This provides an opportunity for the Offeror to clarify or elaborate on the proposal. This is a fact-finding and explanation session only and does not include negotiation. James Madison University

will schedule the time and location of these presentations. Oral presentations are an option of the University and may or may not be conducted. Therefore, proposals should be complete.

**B. SPECIFIC PROPOSAL INSTRUCTIONS**

Proposals should be as thorough and detailed as possible so that James Madison University may properly evaluate your capabilities to provide the required services. Offerors are required to submit the following items as a complete proposal:

1. Return RFP cover sheet and all addenda acknowledgements, if any, signed and filled out as required. (Electronic signature shall be accepted, i.e. Adobe Sign, DocuSign, etc.)
2. Plan and methodology for providing the goods/services as described in Section IV. Statement of Needs of this Request for Proposal.
3. A written narrative statement to include, but not be limited to, the expertise, qualifications, and experience of the firm and resumes of specific personnel to be assigned to perform the work.
4. Offeror Data Sheet, included as *Attachment A* to this RFP.
5. Small Business Subcontracting Plan, included as *Attachment B* to this RFP. Offeror shall provide a Small Business Subcontracting plan which summarizes the planned utilization of Department of Small Business and Supplier Diversity (SBSD)-certified small businesses which include businesses owned by women and minorities, when they have received Department of Small Business and Supplier Diversity (SBSD) small business certification, under the contract to be awarded as a result of this solicitation. This is a requirement for all prime contracts in excess of \$100,000 unless no subcontracting opportunities exist.
6. Identify the amount of sales your company had during the last twelve months with each VASCUPP Member Institution. A list of VASCUPP Members can be found at: [www.VASCUPP.org](http://www.VASCUPP.org).
7. Proposed Cost. See Section X. Pricing Schedule of this Request for Proposal.

**VI. EVALUATION AND AWARD CRITERIA**

**A. EVALUATION CRITERIA**

Proposals shall be evaluated by James Madison University using the following criteria:

	<u>Points</u>
1. Quality of products/services offered and suitability for intended purposes	25
2. Qualifications and experience of Offeror in providing the goods/services	25
3. Specific plans or methodology to be used to perform the services	25
4. Participation of Small, Women-Owned, & Minority (SWaM) Businesses	10

AWARD TO MULTIPLE OFFERORS: Selection shall be made of two or more offerors deemed to be fully qualified and best suited among those submitting proposals on the basis of the evaluation factors included in the Request for Proposals, including price, if so stated in the Request for Proposals. Negotiations shall be conducted with the offerors so selected. Price shall be considered, but need not be the sole determining factor. After negotiations have been conducted with each offeror so selected, the agency shall select the offeror which, in its opinion, has made the best proposal, and shall award the contract to that offeror. The Commonwealth reserves the right to make multiple awards as a result of this solicitation. The Commonwealth may cancel this Request for Proposals or reject proposals at any time prior to an award, and is not required to furnish a statement of the reasons why a particular proposal was not deemed to be the most advantageous. Should the Commonwealth determine in writing and in its sole discretion that only one offeror is fully qualified, or that one offeror is clearly more highly qualified than the others under consideration, a contract may be negotiated and awarded to that offeror. The award document will be a contract incorporating by reference all the requirements, terms and conditions of the solicitation and the contractor's proposal as negotiated.

## VII. GENERAL TERMS AND CONDITIONS

- A. PURCHASING MANUAL: This solicitation is subject to the provisions of the Commonwealth of Virginia's Purchasing Manual for Institutions of Higher Education and Their Vendors and any revisions thereto, which are hereby incorporated into this contract in their entirety. A copy of the manual is available for review at the purchasing office. In addition, the manual may be accessed electronically at <http://www.jmu.edu/procurement> or a copy can be obtained by calling Procurement Services at (540) 568-3145.
- B. APPLICABLE LAWS AND COURTS: This solicitation and any resulting contract shall be governed in all respects by the laws of the Commonwealth of Virginia and any litigation with respect thereto shall be brought in the courts of the Commonwealth. The Contractor shall comply with applicable federal, state and local laws and regulations.
- C. ANTI-DISCRIMINATION: By submitting their proposals, offerors certify to the Commonwealth that they will conform to the provisions of the Federal Civil Rights Act of 1964, as amended, as well as the Virginia Fair Employment Contracting Act of 1975, as amended, where applicable, the Virginians With Disabilities Act, the Americans With Disabilities Act and §10 of the Rules Governing Procurement, Chapter 2, Exhibit J, Attachment 1 (available for review at <http://www.jmu.edu/procurement>). If the award is made to a faith-based organization, the organization shall not discriminate against any recipient of goods, services, or disbursements made pursuant to the contract on the basis of the recipient's religion, religious belief, refusal to participate in a religious practice, or on the basis of race, age, color, gender, sexual orientation, gender identity, or national origin and shall be subject to the same rules as other organizations that contract with public bodies to account for the use of the funds provided; however, if the faith-based organization segregates public funds into separate accounts, only the accounts and programs funded with public funds shall be subject to audit by the public body. (*§6 of the Rules Governing Procurement*).

In every contract over \$10,000 the provisions in 1. and 2. below apply:

1. During the performance of this contract, the contractor agrees as follows:
    - a. The contractor will not discriminate against any employee or applicant for employment because of race, religion, color, sex, sexual orientation, gender identity, national origin, age, disability, or any other basis prohibited by state law relating to discrimination in employment, except where there is a bona fide occupational qualification reasonably necessary to the normal operation of the contractor. The contractor agrees to post in conspicuous places, available to employees and applicants for employment, notices setting forth the provisions of this nondiscrimination clause.
    - b. The contractor, in all solicitations or advertisements for employees placed by or on behalf of the contractor, will state that such contractor is an equal opportunity employer.
    - c. Notices, advertisements, and solicitations placed in accordance with federal law, rule, or regulation shall be deemed sufficient for the purpose of meeting these requirements.
  2. The contractor will include the provisions of 1. above in every subcontract or purchase order over \$10,000, so that the provisions will be binding upon each subcontractor or vendor.
- D. ETHICS IN PUBLIC CONTRACTING: By submitting their proposals, offerors certify that their proposals are made without collusion or fraud and that they have not offered or received any kickbacks or inducements from any other offeror, supplier, manufacturer or subcontractor in connection with their proposal, and that they have not conferred on any public employee having official responsibility for this procurement transaction any payment, loan, subscription, advance, deposit of money, services or anything of more than nominal value, present or promised, unless consideration of substantially equal or greater value was exchanged.
- E. IMMIGRATION REFORM AND CONTROL ACT OF 1986: By entering into a written contract with the Commonwealth of Virginia, the Contractor certifies that the Contractor does not, and shall not during the performance of the contract for goods and services in the Commonwealth, knowingly employ an unauthorized alien as defined in the federal Immigration Reform and Control Act of 1986.
- F. DEBARMENT STATUS: By submitting their proposals, offerors certify that they are not currently debarred by the Commonwealth of Virginia from submitting proposals on contracts for the type of goods and/or services covered by this solicitation, nor are they an agent of any person or entity that is currently so debarred.
- G. ANTITRUST: By entering into a contract, the contractor conveys, sells, assigns, and transfers to the Commonwealth of Virginia all rights, title and interest in and to all causes of action it may now have or hereafter acquire under the antitrust laws of the United States and the Commonwealth of Virginia, relating to the particular goods or services purchased or acquired by the Commonwealth of Virginia under said contract.
- H. MANDATORY USE OF STATE FORM AND TERMS AND CONDITIONS RFPs: Failure to submit a proposal on the official state form provided for that purpose may be a cause for rejection of the proposal. Modification of or additions to the General Terms and Conditions of the solicitation may be cause for rejection of the proposal; however, the Commonwealth reserves the right to decide, on a case by case basis, in its sole discretion, whether to reject such a proposal.

I. CLARIFICATION OF TERMS: If any prospective offeror has questions about the specifications or other solicitation documents, the prospective offeror should contact the buyer whose name appears on the face of the solicitation no later than five working days before the due date. Any revisions to the solicitation will be made only by addendum issued by the buyer.

J. PAYMENT:

1. To Prime Contractor:

- a. Invoices for items ordered, delivered and accepted shall be submitted by the contractor directly to the payment address shown on the purchase order/contract. All invoices shall show the state contract number and/or purchase order number; social security number (for individual contractors) or the federal employer identification number (for proprietorships, partnerships, and corporations).
- b. Any payment terms requiring payment in less than 30 days will be regarded as requiring payment 30 days after invoice or delivery, whichever occurs last. This shall not affect offers of discounts for payment in less than 30 days, however.
- c. All goods or services provided under this contract or purchase order, that are to be paid for with public funds, shall be billed by the contractor at the contract price, regardless of which public agency is being billed.
- d. The following shall be deemed to be the date of payment: the date of postmark in all cases where payment is made by mail, or the date of offset when offset proceedings have been instituted as authorized under the Virginia Debt Collection Act.
- e. Unreasonable Charges. Under certain emergency procurements and for most time and material purchases, final job costs cannot be accurately determined at the time orders are placed. In such cases, contractors should be put on notice that final payment in full is contingent on a determination of reasonableness with respect to all invoiced charges. Charges which appear to be unreasonable will be researched and challenged, and that portion of the invoice held in abeyance until a settlement can be reached. Upon determining that invoiced charges are not reasonable, the Commonwealth shall promptly notify the contractor, in writing, as to those charges which it considers unreasonable and the basis for the determination. A contractor may not institute legal action unless a settlement cannot be reached within thirty (30) days of notification. The provisions of this section do not relieve an agency of its prompt payment obligations with respect to those charges which are not in dispute (*Rules Governing Procurement, Chapter 2, Exhibit J, Attachment 1 § 53; available for review at <http://www.jmu.edu/procurement>*).

2. To Subcontractors:

- a. A contractor awarded a contract under this solicitation is hereby obligated:

- (1) To pay the subcontractor(s) within seven (7) days of the contractor's receipt of payment from the Commonwealth for the proportionate share of the payment received for work performed by the subcontractor(s) under the contract; or
  - (2) To notify the agency and the subcontractors, in writing, of the contractor's intention to withhold payment and the reason.
- b. The contractor is obligated to pay the subcontractor(s) interest at the rate of one percent per month (unless otherwise provided under the terms of the contract) on all amounts owed by the contractor that remain unpaid seven (7) days following receipt of payment from the Commonwealth, except for amounts withheld as stated in (2) above. The date of mailing of any payment by U. S. Mail is deemed to be payment to the addressee. These provisions apply to each sub-tier contractor performing under the primary contract. A contractor's obligation to pay an interest charge to a subcontractor may not be construed to be an obligation of the Commonwealth.
3. Each prime contractor who wins an award in which provision of a SWAM procurement plan is a condition to the award, shall deliver to the contracting agency or institution, on or before request for final payment, evidence and certification of compliance (subject only to insubstantial shortfalls and to shortfalls arising from subcontractor default) with the SWAM procurement plan. Final payment under the contract in question may be withheld until such certification is delivered and, if necessary, confirmed by the agency or institution, or other appropriate penalties may be assessed in lieu of withholding such payment.
  4. The Commonwealth of Virginia encourages contractors and subcontractors to accept electronic and credit card payments.
- K. PRECEDENCE OF TERMS: Paragraphs A through J of these General Terms and Conditions and the Commonwealth of Virginia Purchasing Manual for Institutions of Higher Education and their Vendors, shall apply in all instances. In the event there is a conflict between any of the other General Terms and Conditions and any Special Terms and Conditions in this solicitation, the Special Terms and Conditions shall apply.
- L. QUALIFICATIONS OF OFFERORS: The Commonwealth may make such reasonable investigations as deemed proper and necessary to determine the ability of the offeror to perform the services/furnish the goods and the offeror shall furnish to the Commonwealth all such information and data for this purpose as may be requested. The Commonwealth reserves the right to inspect offeror's physical facilities prior to award to satisfy questions regarding the offeror's capabilities. The Commonwealth further reserves the right to reject any proposal if the evidence submitted by, or investigations of, such offeror fails to satisfy the Commonwealth that such offeror is properly qualified to carry out the obligations of the contract and to provide the services and/or furnish the goods contemplated therein.
- M. TESTING AND INSPECTION: The Commonwealth reserves the right to conduct any test/inspection it may deem advisable to assure goods and services conform to the specifications.
- N. ASSIGNMENT OF CONTRACT: A contract shall not be assignable by the contractor in whole or in part without the written consent of the Commonwealth.
- O. CHANGES TO THE CONTRACT: Changes can be made to the contract in any of the following ways:

1. The parties may agree in writing to modify the scope of the contract. An increase or decrease in the price of the contract resulting from such modification shall be agreed to by the parties as a part of their written agreement to modify the scope of the contract.
  2. The Purchasing Agency may order changes within the general scope of the contract at any time by written notice to the contractor. Changes within the scope of the contract include, but are not limited to, things such as services to be performed, the method of packing or shipment, and the place of delivery or installation. The contractor shall comply with the notice upon receipt. The contractor shall be compensated for any additional costs incurred as the result of such order and shall give the Purchasing Agency a credit for any savings. Said compensation shall be determined by one of the following methods:
    - a. By mutual agreement between the parties in writing; or
    - b. By agreeing upon a unit price or using a unit price set forth in the contract, if the work to be done can be expressed in units, and the contractor accounts for the number of units of work performed, subject to the Purchasing Agency's right to audit the contractor's records and/or to determine the correct number of units independently; or
    - c. By ordering the contractor to proceed with the work and keep a record of all costs incurred and savings realized. A markup for overhead and profit may be allowed if provided by the contract. The same markup shall be used for determining a decrease in price as the result of savings realized. The contractor shall present the Purchasing Agency with all vouchers and records of expenses incurred and savings realized. The Purchasing Agency shall have the right to audit the records of the contractor as it deems necessary to determine costs or savings. Any claim for an adjustment in price under this provision must be asserted by written notice to the Purchasing Agency within thirty (30) days from the date of receipt of the written order from the Purchasing Agency. If the parties fail to agree on an amount of adjustment, the question of an increase or decrease in the contract price or time for performance shall be resolved in accordance with the procedures for resolving disputes provided by the Disputes Clause of this contract or, if there is none, in accordance with the disputes provisions of the Commonwealth of Virginia Purchasing Manual for Institutions of Higher Education and their Vendors. Neither the existence of a claim nor a dispute resolution process, litigation or any other provision of this contract shall excuse the contractor from promptly complying with the changes ordered by the Purchasing Agency or with the performance of the contract generally.
- P. DEFAULT: In case of failure to deliver goods or services in accordance with the contract terms and conditions, the Commonwealth, after due oral or written notice, may procure them from other sources and hold the contractor responsible for any resulting additional purchase and administrative costs. This remedy shall be in addition to any other remedies which the Commonwealth may have.
- Q. INSURANCE: By signing and submitting a proposal under this solicitation, the offeror certifies that if awarded the contract, it will have the following insurance coverage at the time the contract is awarded. For construction contracts, if any subcontractors are involved, the subcontractor will have workers' compensation insurance in accordance with § 25 of the Rules Governing Procurement – Chapter 2, Exhibit J, Attachment 1, and 65.2-800 et. Seq. of the Code of Virginia (available for review at <http://www.jmu.edu/procurement>) The offeror further certifies that the contractor and any subcontractors will maintain these insurance coverage during the entire term of the contract and that all insurance coverage will be provided

by insurance companies authorized to sell insurance in Virginia by the Virginia State Corporation Commission.

MINIMUM INSURANCE COVERAGES AND LIMITS REQUIRED FOR MOST CONTRACTS:

1. Workers' Compensation: Statutory requirements and benefits. Coverage is compulsory for employers of three or more employees, to include the employer. Contractors who fail to notify the Commonwealth of increases in the number of employees that change their workers' compensation requirement under the Code of Virginia during the course of the contract shall be in noncompliance with the contract.
2. Employer's Liability: \$100,000
3. Commercial General Liability: \$1,000,000 per occurrence and \$2,000,000 in the aggregate. Commercial General Liability is to include bodily injury and property damage, personal injury and advertising injury, products and completed operations coverage. The Commonwealth of Virginia must be named as an additional insured and so endorsed on the policy.
4. Automobile Liability: \$1,000,000 combined single limit. *(Required only if a motor vehicle not owned by the Commonwealth is to be used in the contract. Contractor must assure that the required coverage is maintained by the Contractor (or third party owner of such motor vehicle.)*

R. ANNOUNCEMENT OF AWARD: Upon the award or the announcement of the decision to award a contract over \$100,000, as a result of this solicitation, the purchasing agency will publicly post such notice on the DGS/DPS eVA web site ([www.eva.virginia.gov](http://www.eva.virginia.gov)) for a minimum of 10 days.

S. DRUG-FREE WORKPLACE: During the performance of this contract, the contractor agrees to (i) provide a drug-free workplace for the contractor's employees; (ii) post in conspicuous places, available to employees and applicants for employment, a statement notifying employees that the unlawful manufacture, sale, distribution, dispensation, possession, or use of a controlled substance or marijuana is prohibited in the contractor's workplace and specifying the actions that will be taken against employees for violations of such prohibition; (iii) state in all solicitations or advertisements for employees placed by or on behalf of the contractor that the contractor maintains a drug-free workplace; and (iv) include the provisions of the foregoing clauses in every subcontract or purchase order of over \$10,000, so that the provisions will be binding upon each subcontractor or vendor.

For the purposes of this section, "drug-free workplace" means a site for the performance of work done in connection with a specific contract awarded to a contractor, the employees of whom are prohibited from engaging in the unlawful manufacture, sale, distribution, dispensation, possession or use of any controlled substance or marijuana during the performance of the contract.

T. NONDISCRIMINATION OF CONTRACTORS: An offeror, or contractor shall not be discriminated against in the solicitation or award of this contract because of race, religion, color, sex, sexual orientation, gender identity, national origin, age, disability, faith-based organizational status, any other basis prohibited by state law relating to discrimination in employment or because the offeror employs ex-offenders unless the state agency, department

or institution has made a written determination that employing ex-offenders on the specific contract is not in its best interest. If the award of this contract is made to a faith-based organization and an individual, who applies for or receives goods, services, or disbursements provided pursuant to this contract objects to the religious character of the faith-based organization from which the individual receives or would receive the goods, services, or disbursements, the public body shall offer the individual, within a reasonable period of time after the date of his objection, access to equivalent goods, services, or disbursements from an alternative provider.

- U. eVA BUSINESS TO GOVERNMENT VENDOR REGISTRATION, CONTRACTS, AND ORDERS: The eVA Internet electronic procurement solution, website portal [www.eVA.virginia.gov](http://www.eVA.virginia.gov), streamlines and automates government purchasing activities in the Commonwealth. The eVA portal is the gateway for vendors to conduct business with state agencies and public bodies. All vendors desiring to provide goods and/or services to the Commonwealth shall participate in the eVA Internet eprocurement solution by completing the free eVA Vendor Registration. All offerors must register in eVA and pay the Vendor Transaction Fees specified below; failure to register will result in the proposal being rejected. Vendor transaction fees are determined by the date the original purchase order is issued and the current fees are as follows:

Vendor transaction fees are determined by the date the original purchase order is issued and the current fees are as follows:

1. For orders issued July 1, 2014 and after, the Vendor Transaction Fee is:
  - a. Department of Small Business and Supplier Diversity (SBSD) certified Small Businesses: 1% capped at \$500 per order.
  - b. Businesses that are not Department of Small Business and Supplier Diversity (SBSD) certified Small Businesses: 1% capped at \$1,500 per order.
2. For orders issued prior to July 1, 2014 the vendor transaction fees can be found at [www.eVA.virginia.gov](http://www.eVA.virginia.gov).
3. The specified vendor transaction fee will be invoiced by the Commonwealth of Virginia Department of General Services approximately 60 days after the corresponding purchase order is issued and payable 30 days after the invoice date. Any adjustments (increases/decreases) will be handled through purchase order changes.

- V. AVAILABILITY OF FUNDS: It is understood and agreed between the parties herein that the Commonwealth of Virginia shall be bound hereunder only to the extent of the funds available or which may hereafter become available for the purpose of this agreement.

- W. PRICING CURRENCY: Unless stated otherwise in the solicitation, offerors shall state offered prices in U.S. dollars.

- X. E-VERIFY REQUIREMENT OF ANY CONTRACTOR: Any employer with more than an average of 50 employees for the previous 12 months entering into a contract in excess of \$50,000 with James Madison University to perform work or provide services pursuant to such contract shall register and participate in the E-Verify program to verify information and work authorization of its newly hired employees performing work pursuant to any awarded contract.

- Y. CIVILITY IN STATE WORKPLACES: The contractor shall take all reasonable steps to ensure that no individual, while performing work on behalf of the contractor or any subcontractor in connection with this agreement (each, a “Contract Worker”), shall engage in 1) harassment (including sexual harassment), bullying, cyber-bullying, or threatening or violent conduct, or 2) discriminatory behavior on the basis of race, sex, color, national origin, religious belief, sexual orientation, gender identity or expression, age, political affiliation, veteran status, or disability.

The contractor shall provide each Contract Worker with a copy of this Section and will require Contract Workers to participate in training on civility in the State workplace. Upon request, the contractor shall provide documentation that each Contract Worker has received such training.

For purposes of this Section, “State workplace” includes any location, permanent or temporary, where a Commonwealth employee performs any work-related duty or is representing his or her agency, as well as surrounding perimeters, parking lots, outside meeting locations, and means of travel to and from these locations. Communications are deemed to occur in a State workplace if the Contract Worker reasonably should know that the phone number, email, or other method of communication is associated with a State workplace or is associated with a person who is a State employee.

The Commonwealth of Virginia may require, at its sole discretion, the removal and replacement of any Contract Worker who the Commonwealth reasonably believes to have violated this Section.

This Section creates obligations solely on the part of the contractor. Employees or other third parties may benefit incidentally from this Section and from training materials or other communications distributed on this topic, but the Parties to this agreement intend this Section to be enforceable solely by the Commonwealth and not by employees or other third parties.

## VIII. SPECIAL TERMS AND CONDITIONS

- A. AUDIT: The Contractor hereby agrees to retain all books, records, systems, and other documents relative to this contract for five (5) years after final payment, or until audited by the Commonwealth of Virginia, whichever is sooner. The Commonwealth of Virginia, its authorized agents, and/or State auditors shall have full access to and the right to examine any of said materials during said period.
- B. CANCELLATION OF CONTRACT: James Madison University reserves the right to cancel and terminate any resulting contract, in part or in whole, without penalty, upon 60 days written notice to the contractor. In the event the initial contract period is for more than 12 months, the resulting contract may be terminated by either party, without penalty, after the initial 12 months of the contract period upon 60 days written notice to the other party. Any contract cancellation notice shall not relieve the contractor of the obligation to deliver and/or perform on all outstanding orders issued prior to the effective date of cancellation.
- C. IDENTIFICATION OF PROPOSAL ENVELOPE: The signed proposal should be returned in a separate envelope or package, sealed and identified as follows:

From: \_\_\_\_\_  
Name of Offeror Due Date Time

---

Street or Box No.	RFP #
City, State, Zip Code	RFP Title
Name of Purchasing Officer:	

The envelope should be addressed as directed on the title page of the solicitation.

The Offeror takes the risk that if the envelope is not marked as described above, it may be inadvertently opened and the information compromised, which may cause the proposal to be disqualified. Proposals may be hand-delivered to the designated location in the office issuing the solicitation. No other correspondence or other proposals should be placed in the envelope.

- D. LATE PROPOSALS: To be considered for selection, proposals must be received by the issuing office by the designated date and hour. The official time used in the receipt of proposals is that time on the automatic time stamp machine in the issuing office. Proposals received in the issuing office after the date and hour designated are automatically non responsive and will not be considered. The University is not responsible for delays in the delivery of mail by the U.S. Postal Service, private couriers, or the intra university mail system. It is the sole responsibility of the Offeror to ensure that its proposal reaches the issuing office by the designated date and hour.
- E. UNDERSTANDING OF REQUIREMENTS: It is the responsibility of each offeror to inquire about and clarify any requirements of this solicitation that is not understood. The University will not be bound by oral explanations as to the meaning of specifications or language contained in this solicitation. Therefore, all inquiries deemed to be substantive in nature must be in writing and submitted to the responsible buyer in the Procurement Services Office. Offerors must ensure that written inquiries reach the buyer at least five (5) days prior to the time set for receipt of offerors proposals. A copy of all queries and the respective response will be provided in the form of an addendum to all offerors who have indicated an interest in responding to this solicitation. Your signature on your Offer certifies that you fully understand all facets of this solicitation. These questions may be sent via email directly to the Procurement Officer listed on the signature page of this solicitation or by Fax to 540/568-7935.
- F. RENEWAL OF CONTRACT: This contract may be renewed by the Commonwealth for a period of four (4) successive one year periods under the terms and conditions of the original contract except as stated in 1. and 2. below. Price increases may be negotiated only at the time of renewal. Written notice of the Commonwealth's intention to renew shall be given approximately 90 days prior to the expiration date of each contract period.
1. If the Commonwealth elects to exercise the option to renew the contract for an additional one-year period, the contract price(s) for the additional one year shall not exceed the contract price(s) of the original contract increased/decreased by no more than the percentage increase/decrease of the other services category of the CPI-W section of the Consumer Price Index of the United States Bureau of Labor Statistics for the latest twelve months for which statistics are available.
  2. If during any subsequent renewal periods, the Commonwealth elects to exercise the option to renew the contract, the contract price(s) for the subsequent renewal period shall not exceed the contract price(s) of the previous renewal period increased/decreased by more than the percentage increase/decrease of the other services category of the CPI-W section of the Consumer Price Index of the United States Bureau of Labor Statistics for the latest twelve months for which statistics are available.

- G. SUBMISSION OF INVOICES: All invoices shall be submitted within sixty days of contract term expiration for the initial contract period as well as for each subsequent contract renewal period. Any invoices submitted after the sixty day period will not be processed for payment.
- H. OPERATING VEHICLES ON JAMES MADISON UNIVERSITY CAMPUS: Operating vehicles on sidewalks, plazas, and areas heavily used by pedestrians is prohibited. In the unlikely event a driver should find it necessary to drive on James Madison University sidewalks, plazas, and areas heavily used by pedestrians, the driver must yield to pedestrians. For a complete list of parking regulations, please go to [www.jmu.edu/parking](http://www.jmu.edu/parking); or to acquire a service representative parking permit, contact Parking Services at 540.568.3300. The safety of our students, faculty and staff is of paramount importance to us. Accordingly, violators may be charged.
- I. COOPERATIVE PURCHASING / USE OF AGREEMENT BY THIRD PARTIES: It is the intent of this solicitation and resulting contract(s) to allow for cooperative procurement. Accordingly, any public body, (to include government/state agencies, political subdivisions, etc.), cooperative purchasing organizations, public or private health or educational institutions or any University related foundation and affiliated corporations may access any resulting contract if authorized by the Contractor.

Participation in this cooperative procurement is strictly voluntary. If authorized by the Contractor(s), the resultant contract(s) will be extended to the entities indicated above to purchase goods and services in accordance with contract terms. As a separate contractual relationship, the participating entity will place its own orders directly with the Contractor(s) and shall fully and independently administer its use of the contract(s) to include contractual disputes, invoicing and payments without direct administration from the University. No modification of this contract or execution of a separate agreement is required to participate; however, the participating entity and the Contractor may modify the terms and conditions of this contract to accommodate specific governing laws, regulations, policies, and business goals required by the participating entity. Any such modification will apply solely between the participating entity and the Contractor.

The Contractor will notify the University in writing of any such entities accessing this contract. The Contractor will provide semi-annual usage reports for all entities accessing the contract. The University shall not be held liable for any costs or damages incurred by any other participating entity as a result of any authorization by the Contractor to extend the contract. It is understood and agreed that the University is not responsible for the acts or omissions of any entity and will not be considered in default of the contract no matter the circumstances.

Use of this contract(s) does not preclude any participating entity from using other contracts or competitive processes as needed.

- J. SMALL BUSINESS SUBCONTRACTING AND EVIDENCE OF COMPLIANCE:
1. It is the goal of the Commonwealth that 42% of its purchases are made from small businesses. This includes discretionary spending in prime contracts and subcontracts. All potential offerors are required to submit a Small Business Subcontracting Plan. Unless the offeror is registered as a Department of Small Business and Supplier Diversity (SBSD)-certified small business and where it is practicable for any portion of the awarded contract to be subcontracted to other suppliers, the contractor is encouraged to offer such subcontracting opportunities to SBSBD-certified small businesses. This shall not exclude SBSBD-certified women-owned and minority-owned businesses when they have received

SBSD small business certification. No offeror or subcontractor shall be considered a Small Business, a Women-Owned Business or a Minority-Owned Business unless certified as such by the Department of Small Business and Supplier Diversity (SBSD) by the due date for receipt of proposals. If small business subcontractors are used, the prime contractor agrees to report the use of small business subcontractors by providing the purchasing office at a minimum the following information: name of small business with the SBSD certification number or FEIN, phone number, total dollar amount subcontracted, category type (small, women-owned, or minority-owned), and type of product/service provided. **This information shall be submitted to: JMU Office of Procurement Services, Attn: SWAM Subcontracting Compliance, MSC 5720, Harrisonburg, VA 22807 or [swamreporting@jmu.edu](mailto:swamreporting@jmu.edu) .**

2. Each prime contractor who wins an award in which provision of a small business subcontracting plan is a condition of the award, shall deliver to the contracting agency or institution with every request for payment, evidence of compliance (subject only to insubstantial shortfalls and to shortfalls arising from subcontractor default) with the small business subcontracting plan. **This information shall be submitted to: JMU Office of Procurement Services, SWAM Subcontracting Compliance, MSC 5720, Harrisonburg, VA 22807 or [swamreporting@jmu.edu](mailto:swamreporting@jmu.edu) .** When such business has been subcontracted to these firms and upon completion of the contract, the contractor agrees to furnish the purchasing office at a minimum the following information: name of firm with the Department of Small Business and Supplier Diversity (SBSD) certification number or FEIN number, phone number, total dollar amount subcontracted, category type (small, women-owned, or minority-owned), and type of product or service provided. Payment(s) may be withheld until compliance with the plan is received and confirmed by the agency or institution. The agency or institution reserves the right to pursue other appropriate remedies to include, but not be limited to, termination for default.
  3. Each prime contractor who wins an award valued over \$200,000 shall deliver to the contracting agency or institution with every request for payment, information on use of subcontractors that are not Department of Small Business and Supplier Diversity (SBSD)-certified small businesses. When such business has been subcontracted to these firms and upon completion of the contract, the contractor agrees to furnish the purchasing office at a minimum the following information: name of firm, phone number, FEIN number, total dollar amount subcontracted, and type of product or service provided. **This information shall be submitted to: JMU Office of Procurement Services, Attn: SWAM Subcontracting Compliance, MSC 5720, Harrisonburg, VA 22807 or [swamreporting@jmu.edu](mailto:swamreporting@jmu.edu) .**
- K. AUTHORIZATION TO CONDUCT BUSINESS IN THE COMMONWEALTH: A contractor organized as a stock or nonstock corporation, limited liability company, business trust, or limited partnership or registered as a registered limited liability partnership shall be authorized to transact business in the Commonwealth as a domestic or foreign business entity if so required by Title 13.1 or Title 50 of the Code of Virginia or as otherwise required by law. Any business entity described above that enters into a contract with a public body shall not allow its existence to lapse or its certificate of authority or registration to transact business in the Commonwealth, if so required under Title 13.1 or Title 50, to be revoked or cancelled at any time during the term of the contract. A public body may void any contract with a business entity if the business entity fails to remain in compliance with the provisions of this section.
- L. PUBLIC POSTING OF COOPERATIVE CONTRACTS: James Madison University maintains a web-based contracts database with a public gateway access. Any resulting

cooperative contract/s to this solicitation will be posted to the publicly accessible website. Contents identified as proprietary information will not be made public.

- M. CRIMINAL BACKGROUND CHECKS OF PERSONNEL ASSIGNED BY CONTRACTOR TO PERFORM WORK ON JMU PROPERTY: The Contractor shall obtain criminal background checks on all of their contracted employees who will be assigned to perform services on James Madison University property. The results of the background checks will be directed solely to the Contractor. The Contractor bears responsibility for confirming to the University contract administrator that the background checks have been completed prior to work being performed by their employees or subcontractors. The Contractor shall only assign to work on the University campus those individuals whom it deems qualified and permissible based on the results of completed background checks. Notwithstanding any other provision herein, and to ensure the safety of students, faculty, staff and facilities, James Madison University reserves the right to approve or disapprove any contract employee that will work on JMU property. Disapproval by the University will solely apply to JMU property and should have no bearing on the Contractor's employment of an individual outside of James Madison University.
- N. INDEMNIFICATION: Contractor agrees to indemnify, defend and hold harmless the Commonwealth of Virginia, its officers, agents, and employees from any claims, damages and actions of any kind or nature, whether at law or in equity, arising from or caused by the use of any materials, goods, or equipment of any kind or nature furnished by the contractor/any services of any kind or nature furnished by the contractor, provided that such liability is not attributable to the sole negligence of the using agency or to failure of the using agency to use the materials, goods, or equipment in the manner already and permanently described by the contractor on the materials, goods or equipment delivered.
- O. ADDITIONAL GOODS AND SERVICES: The University may acquire other goods or services that the supplier provides than those specifically solicited. The University reserves the right, subject to mutual agreement, for the Contractor to provide additional goods and/or services under the same pricing, terms, and conditions and to make modifications or enhancements to the existing goods and services. Such additional goods and services may include other products, components, accessories, subsystems, or related services that are newly introduced during the term of this Agreement. Such additional goods and services will be provided to the University at favored nations pricing, terms, and conditions.
- P. ADVERTISING: In the event a contract is awarded for supplies, equipment, or services resulting from this proposal, no indication of such sales or services to James Madison University will be used in product literature or advertising without the express written consent of the University. The contractor shall not state in any of its advertising or product literature that James Madison University has purchased or uses any of its products or services, and the contractor shall not include James Madison University in any client list in advertising and promotional materials without the express written consent of the University.
- Q. ELECTRICAL EQUIPMENT STANDARDS: All equipment/material shall conform to the latest issue of all applicable standards as established by National Electrical Manufacturer's Association (NEMA), American National Standards Institute (ANSI), and Occupational Safety & Health Administration (OSHA). All equipment and material, for which there are OSHA standards, shall bear an appropriate label of approval for use intended from a Nationally Recognized Testing Laboratory (NRTL).
- R. FINAL INSPECTION: At the conclusion of the work, the contractor shall demonstrate to the authorized owner's representative that the work is fully operational and in compliance with

contract specifications and codes. Any deficiencies shall be promptly and permanently corrected by the contractor at the contractor's sole expense prior to final acceptance of the work.

- S. PRIME CONTRACTOR RESPONSIBILITIES: The contractor shall be responsible for completely supervising and directing the work under this contract and all subcontractors that he may utilize, using his best skill and attention. Subcontractors who perform work under this contract shall be responsible to the prime contractor. The contractor agrees that he is as fully responsible for the acts and omissions of his subcontractors and of persons employed by them as he is for the acts and omissions of his own employees.
- T. WORK SITE DAMAGES: Any damage to existing utilities, equipment or finished surfaces resulting from the performance of this contract shall be repaired to the Commonwealth's satisfaction at the contractor's expense.
- U. STANDARDS OF CONDUCT: The work site will be occupied by students and University Personnel during the times work is performed. Contractor and Contractor's personnel shall exercise a particularly high level of discipline, safety, and cooperation at all times while on the job site. The Contractor shall be responsible for controlling employee conduct, for assuring that its employees are not boisterous or rude, and assuring that they are not engaging in any destructive or criminal activity. The Contractor is also responsible for ensuring that its employees do not disturb papers on desks, or open desk drawers, cabinets, or briefcases, or use State phones, and the like, except as authorized.
- V. WARRANTY (COMMERICAL): The contractor agrees that the goods or services furnished under any award resulting from this solicitation shall be covered by the most favorable commercial warranties the contractor gives any customer for such goods or services and that the rights and remedies provided therein are in addition to and do not limit those available to the Commonwealth by any other clause of this solicitation. A copy of this warranty should be furnished with the proposal.
- W. KEYS: If the Contractor is given keys for this project, it is the Contractor's responsibility to return the keys when the contract is terminated, as well as for the safekeeping of the keys during the contract period. The Contractor shall not loan or duplicate the keys. In the event the Contractor loses the keys, they will be charged for the replacement of the keys and any locks which are rekeyed or replaced.
- X. CONTRACTOR/SUBCONTRACTOR LICENSE REQUIREMENT: By my signature on this solicitation, I certify that this firm/individual and subcontractor is properly licensed for providing the goods/services specified.

Contractor Name: \_\_\_\_\_ Subcontractor Name: \_\_\_\_\_

License # \_\_\_\_\_ Type \_\_\_\_\_

- Y. DELIVERY AND STORAGE: It shall be the responsibility of the contractor to make all arrangements for delivery, unloading, receiving and storing materials in the building during installation. The owner will not assume any responsibility for receiving these shipments. Contractor shall check with the owner and make necessary arrangements for security and storage space in the building during installation.

- Z. ASBESTOS: Whenever and wherever during the course of performing any work under this contract, the contractor discovers the presence of asbestos or suspects that asbestos is present, he shall stop the work immediately, secure the area, notify the building owner and await positive identification of the suspect material. During the downtime in such a case, the contractor shall not disturb any surrounding surfaces but shall protect the area with suitable dust covers. In the event the contractor is delayed due to the discovery of asbestos or suspected asbestos, then a mutually agreed extension of time to perform the work shall be allowed the contractor but without additional compensation due to the time extension.
- AA. PRIME CONTRACTOR RESPONSIBILITIES: The contractor shall be responsible for completely supervising and directing the work under this contract and all subcontractors that he may utilize, using his best skill and attention. Subcontractors who perform work under this contract shall be responsible to the prime contractor. The contractor agrees that he is as fully responsible for the acts and omissions of his subcontractors and of persons employed by them as he is for the acts and omissions of his own employees.
- BB. SUBCONTRACTS: No portion of the work shall be subcontracted without prior written consent of the purchasing agency. In the event that the contractor desires to subcontract some part of the work specified herein, the contractor shall furnish the purchasing agency the names, qualifications and experience of their proposed subcontractors. The contractor shall, however, remain fully liable and responsible for the work to be done by its subcontractor(s) and shall assure compliance with all requirements of the contract.
- CC. WORK ESTIMATES: Under this time and material contract, the contractor shall furnish the agency with a non-binding written estimate of the total costs to complete the work required. The estimate must include the labor category(ies), the contractor's hourly rates specified in the contract, and the total material cost. Material costs shall be billed at contractor's actual invoice costs (contractor shall furnish copies of all invoices for materials) or discount off the list price, whichever is specified in the contract. If the agency determines that the estimated price is not fair and reasonable, the agency has the right to ask the contractor to reevaluate the estimate. If the revised estimate is determined to be not fair and reasonable, the agency reserves the right to obtain additional quotes from other vendors. A work order will be issued to the contractor, as the authority to proceed with the work, which will incorporate the contractor's estimate and the terms and conditions of the contract. The contractor and his/her personnel shall log in with the designated contract administrator each day before and after work to confirm labor hours.
- DD. WORK SITE DAMAGES: Any damage to existing utilities, equipment or finished surfaces resulting from the performance of this contract shall be repaired to the Commonwealth's satisfaction at the contractor's expense.

## **IX. METHOD OF PAYMENT**

The contractor will be paid based on invoices submitted in accordance with the solicitation and any negotiations. James Madison University recognizes the importance of expediting the payment process for our vendors and suppliers; we request that our vendors and suppliers enroll in our bank's Comprehensive Payable options: either the Virtual Payables Virtual Card or the PayMode-X electronic deposit (ACH) to your bank account so that future payments are made electronically. Contractors signed up for the Virtual Payables process will receive the benefit of being paid Net 15. Additional information is available online at:

<http://www.jmu.edu/financeoffice/accounting-operations-disbursements/cash-investments/vendor-payment-methods.shtml>

## X. PRICING SCHEDULE

The offeror shall provide pricing for all products and services included in proposal indicating one-time and on-going costs. The resulting contract will be cooperative and pricing shall be inclusive for the attached Zone Map, of which JMU falls within Zone 2.

### Labor Rates

Ceiling Tile Installation	Regular Working Hours	Overtime Hours
Project manager		
Lead Crew		
Helper		
Plaster Services	Regular Working Hours	Overtime Hours
Project manager		
Lead Crew		
Helper		
Drywall services	Regular Working Hours	Overtime Hours
Project manager		
Lead Crew		
Helper		

### Parts and Supplies

Materials/Parts	List Price	% Discount Off MSRP	University Price
(Fill in as needed)			

### Equipment Rentals

Type of Equipment	Price Breakdown
Lift	
Misc. Other	

**Other Pricing.** Specify any associated charge card processing fees, if applicable, to be billed to the university.

Other Charges or Fees	Amount
Charge Card Processing Fee	
Misc. Other	

## **XI. ATTACHMENTS**

Attachment A: Offeror Data Sheet

Attachment B: Small, Women, and Minority-owned Business (SWaM) Utilization Plan

Attachment C: Standard Contract Sample

Attachment D: Zone Map

Attachment E: SWaM Sub-contractor Reporting Template

Attachment F: The JMU [Design and Construction Guidelines](#) (as amended)

ATTACHMENT A

OFFEROR DATA SHEET

TO BE COMPLETED BY OFFEROR

1. QUALIFICATIONS OF OFFEROR: Offerors must have the capability and capacity in all respects to fully satisfy the contractual requirements.
2. YEARS IN BUSINESS: Indicate the length of time you have been in business providing these types of goods and services.

Years \_\_\_\_\_ Months \_\_\_\_\_

3. REFERENCES: Indicate below a listing of at least five (5) organizations, either commercial or governmental/educational, that your agency is servicing. Include the name and address of the person the purchasing agency has your permission to contact.

CLIENT	LENGTH OF SERVICE	ADDRESS	CONTACT PERSON/PHONE #
--------	-------------------	---------	---------------------------

---

---

---

---

---

4. List full names and addresses of Offeror and any branch offices which may be responsible for administering the contract.

---

---

---

---

5. RELATIONSHIP WITH THE COMMONWEALTH OF VIRGINIA: Is any member of the firm an employee of the Commonwealth of Virginia who has a personal interest in this contract pursuant to the [CODE OF VIRGINIA](#), SECTION 2.2-3100 – 3131?

YES  NO

IF YES, EXPLAIN: \_\_\_\_\_

---

---

---

ATTACHMENT B

Small, Women and Minority-owned Businesses (SWaM) Utilization Plan

Offeror Name: \_\_\_\_\_ Preparer Name: \_\_\_\_\_

Date: \_\_\_\_\_

Is your firm a **Small Business Enterprise** certified by the Department of Small Business and Supplier Diversity (SBSD)? Yes \_\_\_\_\_ No \_\_\_\_\_

If yes, certification number: \_\_\_\_\_ Certification date: \_\_\_\_\_

Is your firm a **Woman-owned Business Enterprise** certified by the Department of Small Business and Supplier Diversity (SBSD)? Yes \_\_\_\_\_ No \_\_\_\_\_

If yes, certification number: \_\_\_\_\_ Certification date: \_\_\_\_\_

Is your firm a **Minority-Owned Business Enterprise** certified by the Department of Small Business and Supplier Diversity (SBSD)? Yes \_\_\_\_\_ No \_\_\_\_\_

If yes, certification number: \_\_\_\_\_ Certification date: \_\_\_\_\_

Is your firm a **Micro Business** certified by the Department of Small Business and Supplier Diversity (SBSD)? Yes \_\_\_\_\_ No \_\_\_\_\_

If yes, certification number: \_\_\_\_\_ Certification date: \_\_\_\_\_

**Instructions:** *Populate the table below to show your firm's plans for utilization of small, women-owned and minority-owned business enterprises in the performance of the contract. Describe plans to utilize SWAMs businesses as part of joint ventures, partnerships, subcontractors, suppliers, etc.*

**Small Business:** "Small business " means a business, independently owned or operated by one or more persons who are citizens of the United States or non-citizens who are in full compliance with United States immigration law, which, together with affiliates, has 250 or fewer employees, or average annual gross receipts of \$10 million or less averaged over the previous three years.

**Woman-Owned Business Enterprise:** A business concern which is at least 51 percent owned by one or more women who are U.S. citizens or legal resident aliens, or in the case of a corporation, partnership or limited liability company or other entity, at least 51 percent of the equity ownership interest in which is owned by one or more women, and whose management and daily business operations are controlled by one or more of such individuals. **For purposes of the SWAM Program, all certified women-owned businesses are also a small business enterprise.**

**Minority-Owned Business Enterprise:** A business concern which is at least 51 percent owned by one or more minorities or in the case of a corporation, partnership or limited liability company or other entity, at least 51 percent of the equity ownership interest in which is owned by one or more minorities and whose management and daily business operations are controlled by one or more of such individuals. **For purposes of the SWAM Program, all certified minority-owned businesses are also a small business enterprise.**

**Micro Business** is a certified Small Business under the SWaM Program and has no more than twenty-five (25) employees AND no more than \$3 million in average annual revenue over the three-year period prior to their certification.

**All small, women, and minority owned businesses must be certified by the Commonwealth of Virginia Department of Small Business and Supplier Diversity (SBSD) to be counted in the SWAM program. Certification applications are available through SBSD at 800-223-0671 in Virginia, 804-786-6585 outside Virginia, or online at <http://www.sbsd.virginia.gov/> (Customer Service).**

***RETURN OF THIS PAGE IS REQUIRED***

**ATTACHMENT B (CNT'D)**  
 Small, Women and Minority-owned Businesses (SWaM) Utilization Plan

Procurement Name and Number: \_\_\_\_\_

Date Form Completed: \_\_\_\_\_

Listing of Sub-Contractors, to include, Small, Woman Owned and Minority Owned Businesses  
 for this Proposal and Subsequent Contract

Offeror / Proposer:

\_\_\_\_\_  
 Firm

\_\_\_\_\_  
 Address

\_\_\_\_\_  
 Contact Person/No.

Sub-Contractor's Name and Address	Contact Person & Phone Number	SBSD Certification Number	Services or Materials Provided	Total Subcontractor Contract Amount (to include change orders)	Total Dollars Paid Subcontractor to date (to be submitted with request for payment from JMU)

*(Form shall be submitted with proposal and if awarded, a SWaM Sub-contractor Reporting Form shall be submitted to [swamreporting@jmu.edu](mailto:swamreporting@jmu.edu))*

**RETURN OF THIS PAGE IS REQUIRED**

ATTACHMENT C



COMMONWEALTH OF VIRGINIA
STANDARD CONTRACT

Contract No. \_\_\_\_\_

This contract entered into this \_\_\_\_\_ day of \_\_\_\_\_ 20\_\_\_\_, by \_\_\_\_\_ hereinafter called the "Contractor" and Commonwealth of Virginia, James Madison University called the "Purchasing Agency".

WITNESSETH that the Contractor and the Purchasing Agency, in consideration of the mutual covenants, promises and agreements herein contained, agree as follows:

SCOPE OF CONTRACT: The Contractor shall provide the services to the Purchasing Agency as set forth in the Contract Documents.

PERIOD OF PERFORMANCE: From \_\_\_\_\_ through \_\_\_\_\_

The contract documents shall consist of:

- (1) This signed form;
(2) The following portions of the Request for Proposals dated \_\_\_\_\_:
(a) The Statement of Needs,
(b) The General Terms and Conditions,
(c) The Special Terms and Conditions together with any negotiated modifications of those Special Conditions;
(d) List each addendum that may be issued
(3) The Contractor's Proposal dated \_\_\_\_\_ and the following negotiated modification to the Proposal, all of which documents are incorporated herein.
(a) Negotiations summary dated \_\_\_\_\_.

IN WITNESS WHEREOF, the parties have caused this Contract to be duly executed intending to be bound thereby.

CONTRACTOR:

PURCHASING AGENCY:

By: \_\_\_\_\_ (Signature)

By: \_\_\_\_\_ (Signature)

\_\_\_\_\_  
(Printed Name)

\_\_\_\_\_  
(Printed Name)

Title: \_\_\_\_\_

Title: \_\_\_\_\_

# ATTACHMENT D

## Zone Map



### Virginia Association of State College & University Purchasing Professionals (VASCUPP)

#### List of member institutions by zones

- |  |  |   |
|--|--|---|
| <b><u>Zone 1</u></b><br>George Mason University (Fairfax)              | <b><u>Zone 2</u></b><br>James Madison University (Harrisonburg)  | <b><u>Zone 3</u></b><br>University of Virginia (Charlottesville)  |
| <b><u>Zone 4</u></b><br>University of Mary Washington (Fredericksburg) | <b><u>Zone 5</u></b><br>Christopher Newport University (Newport News)<br>College of William and Mary (Williamsburg)<br>Norfolk State University (Norfolk)<br>Old Dominion University (Norfolk) | <b><u>Zone 6</u></b><br>Virginia Commonwealth University (Richmond)<br>Virginia State University (Petersburg) |
| <b><u>Zone 7</u></b><br>Longwood University (Farmville)                | <b><u>Zone 8</u></b><br>Virginia Military Institute (Lexington)<br>Virginia Tech (Blacksburg)<br>Radford University (Radford)  | <b><u>Zone 9</u></b><br>University of Virginia - Wise (Wise)  |



# DESIGN AND CONSTRUCTION GUIDELINES

James Madison University (JMU) is devoted to building and maintaining the most energy efficient and cost-effective university possible. While keeping the needs of our students and staff first in every respect, we must also consider the weight of our actions on both a local and global scale. Our efforts in reducing overall energy demand and greenhouse gas emissions from the consumption of fossil fuels blend seamlessly with our goal of maximizing the value of all our facilities. Implementing the best available technologies in every aspect of our building and site design is critical to help us best serve our students, faculty and the local community. The delicate balance between the budget and environmental concerns has led us to develop a campus-wide initiative to reduce our energy consumption. JMU is at the forefront of a far-reaching effort to reduce our overall environmental impact.

Primary attention shall be given to the reduction of energy use and water consumption by focusing on the reduction of the total lifetime building energy load. Since alterations to a building's envelope are generally the most cost-prohibitive, priority shall be given to all concealed insulation components. Windows and doors are typically the largest contributing factor in the building's heating and cooling load, and quite expensive to replace; therefore, providing the most energy efficient and durable fenestration is the next priority for JMU. By focusing on our first two challenges, the impact of the HVAC system, our third critical load component, will be greatly reduced. Air distribution systems, and other HVAC system components that are generally inaccessible, shall be designed with consideration for future, more budget-friendly equipment changes.

As evidenced by our numerous existing campus buildings, we can build our buildings for more than a 100-year life cycle. Knowing that the most efficient use of an older building is the re-use of an older building, we are planning our university for many generations to come. Our university is characterized by many things, one of those being our beautiful campus. As we cherish the history and appeal of our existing Bluestone campus, we want our future generations to embrace the work we do today in the same regard.

Our staff consists of subject matter experts from every branch of the construction industry and we are willing and ready to help improve our campus by every available means.

The James Madison University Design and Construction Guidelines (JMUDCG) are intended to provide both performance-based and prescriptive guidance to the A/E and the contractor in the planning, preparation and installation phases of all JMU construction projects. This document is also meant to provide instruction as to certain JMU requirements that may go above and beyond typical code requirements. These guidelines are in place to ensure the best possible long-term outcome for JMU by creating sustainable buildings and infrastructure, while maintaining consistency with the current campus-wide design and JMU master plan.

This document DOES NOT supersede applicable state codes, Division of Engineering and Buildings (DEB) requirements, or any other governing federal, state, and/or local laws. However, this guideline may exclude certain exceptions as listed in the standard codes. Designers are not to reference this guideline in the project specifications, but shall incorporate the contents of this guideline into the building and site design. Any conflict between this document and any of the aforementioned laws or codes shall be brought to the immediate attention of the Director of Facilities Engineering & Construction.

The architect, engineer, designer of record and/or contractor(s) shall be responsible for the entire contents of this document. This document contains the *JMU Design and Construction Guidelines Compliance Form*, and this form shall be filled out, in its entirety, then given to the JMU Project Manager (PM) at the submission of the preliminary construction drawings. Any deviation(s) from these guidelines shall require the exception(s) to be considered through the submission of the *JMU Design Standards Variance Form* that is available from your JMU PM. Variance requests shall provide proof of undue hardship or substantial cost-benefit reasons to be considered by the Director of Facilities Engineering & Construction for approval.

Thank you for helping us continue our tradition of excellence at

**JAMES MADISON UNIVERSITY**

## STAFF DIRECTORY

Business Services Administration		
Craig Short	Associate Vice President	540-568-2535

Facilities		
Gary Shears	<i>Executive Director, Facilities and Construction</i>	540-568-2850

Engineering and Construction		
Kirk Morris	<i>Director, Engineering and Construction</i>	540-568-3003
***Engineering***		
Miranda Eppard	Admin. Assistant, Engineering	540-568-6315
Carrie Comer	Admin. Assistant, Engineering	540-568-4067
Anna Hudick	Senior Mechanical Engineer	540-568-6738
Seth Arnold	Project Manager	540-568-5502
Brian Naftel	Senior Mechanical Engineer	540-568-3692
Tim Shantz	Construction Engineer	540-568-5909
Jared Combs	Construction Engineer	540-568-6580
Clark Driver	Construction Engineer	540-568-7290
Mike Derrow	Construction Engineer	540-568-7127
Dennis Kiracofe	AutoCAD Drafting Supervisor	540-568-8136
John Khampavong	Engineering Tech/Lead Utility Locator	540-568-4068
Abe Kaufman	Energy Conservation & Sustainability Manager	540-568-4201
Alison Sloop	Stormwater Coordinator	540-568-3174
Chelsea Thomas	Stormwater Specialist	540-568-7606
Sam Hottinger	GES Supervisor	540-568-4029
Shane Long	Facility inspector I, FICAS Property Inspector	540-568-6146
Nate Brown	Sustainability Analyst	540-568-6798
Department Fax		540-568-3547
***Planning & Construction***		
Vacant	Director, Facilities Planning and Construction	
Julie Huffman	Office Manager	540-568-3001
Scott Wachter	Capital Outlay Project Manager	540-568-3006
Glenn Wayland	Capital Outlay Project Manager	540-568-6345
Nancy Cornwell	Capital Outlay Project Engineer	540-568-3008
Department Fax		540-568-7969

## STAFF DIRECTORY

Operations		
<b>Rodney Lam</b>	<i>Associate Director</i>	540-568-6905
<b>Chris Cooley</b>	Manager, Building Support Systems (Safety/Generator/Locks)	540-568-3337
<b>Matthew Jefferson</b>	Manager (HVAC/B.A.S./Electrical/Plumbing)	540-568-4303
<b>Dennis Hart</b>	Manager, Power Plant	540-568-6235
<b>Robert Weese</b>	Manager, Central Operations	540-568-4376
<b>Brian Owens</b>	Manager, Trades	540-568-6870

Support Services		
<b>Vacant</b>	<i>Assistant Director</i>	540-568-3766
<b>Lori Butler</b>	Interim Assistant Director, Support Services Budget Manager, Accounting	540-568-6024
<b>Carlene Heatwole</b>	Business Process Analyst, Business Services	540-568-3645
<b>Julie Dove</b>	Senior Planner, Events	540-568-4103
<b>Sarah Donaire</b>	I.T. Manager/Systems Administrator	540-568-6838
<b>Doug Judy</b>	Transportation Manager	540-568-3609

Environmental Services		
<b>Frank Lucas</b>	<i>Assistant Director</i>	540-568-3411
<b>Scott Jones</b>	Manager, Landscaping/Horticulture and Floriculture	540-568-7929
<b>Patrick Puffenbarger</b>	Assistant Manager, Landscaping / Pest Management / Athletic Events	540-568-3352
<b>Jason Rexrode</b>	Assistant Manager of Recycling, and Equipment Repairs for Housekeeping	540-568-3352
<b>Debbie Morris</b>	Housekeeping Manager, Dorms	540-568-6401
<b>Vickie Raines</b>	Housekeeping Manger, Academic Buildings / Athletic Events	540-568-5118
<b>Yolanda Morris</b>	Housekeeping Manager, Nightshift housekeeping / 2 <sup>nd</sup> Shift Housekeeping / Carpet Cleaning.	540-568-6028
<b>Dawn Burbank</b>	Environmental Services Office Manager	540-568-6074
<b>Tara Cullars</b>	Environmental Services Office Manager	540-568-4030

---

## Division 01 – GENERAL REQUIREMENTS

### 1.1 [General Requirements](#)

- 1.1.1 [Codes](#)
- 1.1.2 [Building & Site Efficiency](#)
- 1.1.3 [Hot Work & Fire Watch](#)
- 1.1.4 [Occupied Buildings](#)
- 1.1.5 [Confined Space](#)
- 1.1.6 [Inspections](#)
- 1.1.7 [Clean Air Permit Requirements](#)

### 1.2 [Architectural Requirements](#)

- 1.2.1 [Purpose](#)
- 1.2.2 [Site Design](#)
- 1.2.3 [Building Design](#)
- 1.2.4 [Acoustics](#)
- 1.2.5 [Security Control Rooms](#)
- 1.2.6 [General Security Classifications](#)
- 1.2.7 [Exterior Security](#)
- 1.2.8 [Card Readers](#)
- 1.2.9 [Custodial Areas](#)
- 1.2.10 [Equipment Rooms](#)
- 1.2.11 [Telecommunications Rooms](#)
- 1.2.12 [Maintenance Rooms](#)
- 1.2.13 [Laundry Rooms](#)
- 1.2.14 [Lactation Rooms](#)
- 1.2.15 [Trash/Recycling Rooms](#)
- 1.2.16 [Loading Areas](#)
- 1.2.17 [Offices](#)
- 1.2.18 [Instructional Spaces](#)
- 1.2.19 [Restrooms](#)
- 1.2.20 [Lobbies](#)
- 1.2.21 [MSDS](#)
- 1.2.22 [Stairs](#)
- 1.2.23 [Vending Machines](#)
- 1.2.24 [Bicycle Racks](#)
- 1.2.25 [Mail Rooms](#)
- 1.2.26 [Numbering](#)
- 1.2.27 [Fire Pits](#)
- 1.2.28 [Gas Fireplaces](#)

### 1.3 [Abatement Procedures](#)

- 1.3.1 [Scope](#)
- 1.3.2 [Asbestos](#)
- 1.3.3 [Lead Paint](#)
- 1.3.4 [Other Material](#)

### 1.4 [Construction Drawings](#)

- 1.4.1 [General](#)
- 1.4.2 [Drawing Formats](#)
- 1.4.3 [Auto Standards](#)
- 1.4.4 [CAD Drawing Structure](#)
- 1.4.5 [BIM Standards](#)
- 1.4.6 [PDF Requirements](#)
- 1.4.7 [Layering Standards](#)
- 1.4.8 [AIA Layering Format](#)
- 1.4.9 [Lines, Objects & Entities](#)
- 1.4.10 [Scale & Units](#)
- 1.4.11 [Model & Paper Space Usage](#)
- 1.4.12 [XREFS](#)
- 1.4.13 [AutoCAD Drawing Support Files](#)
- 1.4.14 [File Transmittal](#)
- 1.4.15 [Error-Free AutoCAD Delivery](#)

## TABLE OF CONTENTS

### 1.5 [Project Completion](#)

- 1.5.1 [“As-Built Record Drawings](#)
- 1.5.2 [O&M Manuals](#)
- 1.5.3 [Record Submittals and RFI’s](#)

- 1.5.4 [Maintenance Materials](#)
- 1.5.5 [Warranties](#)

### 1.6 [Erosion and Sediment Control / Stormwater](#)

- 1.6.1 [General](#)
- 1.6.2 [Plan Submittal & Review](#)
- 1.6.3 [Construction Prerequisites](#)
- 1.6.4 [SWPPP](#)

- 1.6.5 [Construction](#)
- 1.6.6 [Project Completion](#)
- 1.6.7 [Record Drawing Documentation](#)
- 1.6.8 [CGP & NOT](#)

### 1.7 [Mock-Up Requirements](#)

- 1.7.1 [General](#)
- 1.7.2 [Mock-Up Construction](#)

- 1.7.3 [Mock-Up Approval](#)

---

## Division 03 – CONCRETE

### 3.1 [Footings & Foundations](#)

- 3.1.1 [Footings](#)
- 3.1.2 [Foundations](#)

### 3.2 [Concrete](#)

- 3.2.1 [General](#)
- 3.2.2 [Concrete Mixes](#)
- 3.2.3 [Formwork](#)
- 3.2.4 [Slump](#)
- 3.2.5 [Placement](#)
- 3.2.6 [Interior Slabs](#)
- 3.2.7 [Sidewalks & Exterior Slabs](#)

---

## Division 04 – MASONRY

### 4.1 [Masonry](#)

- 4.1.1 [General](#)
- 4.1.2 [Sills](#)
- 4.1.3 [Mortar](#)
- 4.1.4 [Flashing](#)
- 4.1.5 [Grout](#)
- 4.1.6 [Accessories](#)

### 4.2 [Bluestone](#)

- 4.2.1 [General](#)
- 4.2.2 [Bluestone Sources](#)
- 4.2.3 [Veneer Anchors and Embedded Accessories](#)
- 4.2.4 [Mortar and Grout](#)
- 4.2.5 [Site Delivery and Storage](#)
- 4.2.6 [Field Dressing/Facing and Cutting of Bluestone](#)
- 4.2.7 [Installation](#)
- 4.2.8 [Protection of Masonry Work During Installation and Cleaning](#)

## Division 05 – METALS

### 5.1 [Steel](#)

5.1.1 [General](#)

5.1.2 [Welding & Tension](#)

5.1.3 [Handrails & Guardrails](#)

5.1.4 [Stairs & Ladders](#)

---

## Division 06 – WOOD, PLASTICS, AND COMPOSITES

### 6.1 [Wood & Plastics](#)

---

## Division 07 – THERMAL AND MOISTURE PROTECTION

### 7.1 [Thermal & Moisture](#)

7.1.1 [Moisture](#)

7.1.2 [Vapor](#)

7.1.3 [Thermal](#)

7.1.4 [Flashing](#)

### 7.2 [Roofing](#)

7.2.1 [General](#)

7.2.2 [Coverings](#)

7.2.3 [Metal](#)

---

## Division 08 – OPENINGS

### 8.1 [Openings](#)

8.1.1 [General](#)

8.1.2 [Hardware](#)

8.1.3 [Security](#)

8.1.4 [Performance](#)

---

## Division 09 – FINISHES

### 9.1 [Finishes](#)

9.1.1 [Ceilings](#)

9.1.2 [Walls](#)

9.1.3 [Floors](#)

9.1.4 [Paint](#)

---

## Division 10 – SPECIALTIES

### 10.1 [Signage](#)

---

## Division 12 – FURNISHINGS

### 12.1 [Interior Furnishings](#)

12.1.1 [Furnishings](#)

12.1.2 [Window Coverings](#)

---

Division 14 – CONVEYING EQUIPMENT

14.1 [Conveying Systems](#)

Division 21 – FIRE SUPPRESSION

21.1 [Fire Suppression](#)

21.1.1 [General](#)

Division 22 – PLUMBING

22.1 [Plumbing](#)

22.1.1 [General](#)

22.1.4 [D/W/V](#)

22.1.2 [Exterior Service](#)

22.1.5 [Valves & Fixtures](#)

22.1.3 [Interior Service](#)

Division 23 – HEATING, VENTILATING AND AIR CONDITIONING

23.1 [Mechanical](#)

23.1.1 [Design](#)

23.1.17 [Refrigerant Monitors](#)

23.1.2 [General](#)

23.1.18 [Refrigerant Management](#)

23.1.3 [Location & Equipment](#)

23.1.19 [Chillers](#)

23.1.4 [Metering](#)

23.1.20 [VFDs](#)

23.1.5 [Ventilation & Outdoor Air](#)

23.1.21 [Glycol](#)

23.1.6 [Water Treatment](#)

23.1.22 [HVAC Controls](#)

23.1.7 [Cooling Towers](#)

23.1.23 [IT Computer Rooms](#)

23.1.8 [AHUs & RTUs](#)

23.1.24 [Environmental Chambers](#)

23.1.9 [Fan Coil Units](#)

23.1.25 [Specialty Systems](#)

23.1.10 [VAVs](#)

23.1.26 [ID of Equipment & Valves](#)

23.1.11 [Exhaust & Make-up Air](#)

23.1.27 [Identification of Piping](#)

23.1.12 [Pumps](#)

23.1.28 [Small Packaged Boilers](#)

23.1.13 [Split Systems](#)

23.1.29 [Fire Dampers](#)

23.1.14 [Air Filters](#)

23.1.30 [Compressed Air](#)

23.1.15 [Pipe Insulation](#)

23.1.31 [Kitchen Exhaust](#)

23.1.16 [Refrigeration](#)

23.1.32 [Humidification](#)

23.2 [Steam](#)

23.2.1 [General](#)

23.2.6 [Control Valves](#)

23.2.2 [Condensate Pumps](#)

23.2.7 [Underground Piping](#)

23.2.3 [Gaskets](#)

23.2.8 [Humidification](#)

23.2.4 [Heating Water Converters](#)

23.2.9 [Safety Relief Valves](#)

23.2.5 [Flow Meters](#)

23.2.10 [Isolation Valves](#)

---

## Division 25 – BUILDING AUTOMATION SYSTEMS

### 25.1 [Building Automation Systems](#)

25.1.1	<a href="#">General</a>	25.1.5	<a href="#">Submittals &amp; As-Built Drawings</a>
25.1.2	<a href="#">Base Bid Process</a>	25.1.6	<a href="#">Project Execution</a>
25.1.3	<a href="#">Qualified Bidders</a>	25.1.7	<a href="#">Approved Hardware</a>
25.1.4	<a href="#">Quality Assurance</a>	25.1.8	<a href="#">Utility Metering</a>

---

## Division 26 – ELECTRICAL

### 26.1 [Electrical](#)

26.1.1	<a href="#">General</a>	26.1.8	<a href="#">Life Safety</a>
26.1.2	<a href="#">Inspections</a>	26.1.9	<a href="#">General Lighting</a>
26.1.3	<a href="#">Service</a>	26.1.10	<a href="#">Interior Lighting</a>
26.1.4	<a href="#">Branch</a>	26.1.11	<a href="#">Exterior Lighting</a>
26.1.5	<a href="#">Wiring</a>	26.1.12	<a href="#">Classrooms</a>
26.1.6	<a href="#">Exterior</a>	26.1.13	<a href="#">Fire Alarms</a>
26.1.7	<a href="#">Conduit</a>		

### 26.2 [Generators](#)

---

## Division 27 – COMMUNICATIONS

### 27.1 [Telecommunications](#)

27.1.1	<a href="#">General</a>	27.1.9	<a href="#">Emergency Phones</a>
27.1.2	<a href="#">Building Telecom Entrance</a>	27.1.10	<a href="#">Junction Boxes</a>
27.1.3	<a href="#">MDFs &amp; IDFs</a>	27.1.11	<a href="#">Roof Penetrations</a>
27.1.4	<a href="#">Work Areas</a>	27.1.12	<a href="#">Wireless Access Points</a>
27.1.5	<a href="#">Outlet Boxes</a>	27.1.13	<a href="#">Classrooms</a>
27.1.6	<a href="#">Horizontal Distribution System</a>	27.1.14	<a href="#">Manhole Specifications</a>
27.1.7	<a href="#">Elevators</a>	27.1.15	<a href="#">Buried Conduit Specifications</a>
27.1.8	<a href="#">Grounding</a>	27.1.16	<a href="#">Completion Documents</a>

### 27.2 [Distributed Antenna System \(DAS\)](#)

27.2.1	<a href="#">Head-End Space</a>	27.2.4	<a href="#">Roof Penetration and Rooftop Antenna Mounting Location</a>
27.2.2	<a href="#">Power Requirements</a>		
27.2.3	<a href="#">Pathways</a>	27.2.5	<a href="#">Grounding and Lightning Protection Requirements</a>

## Division 31 – EARTHWORK

### 31.1 [Excavation & Grading](#)

31.1.1 [Excavation](#)

31.1.2 [Grading](#)

---

## Division 32 – EXTERIOR IMPROVEMENTS

### 32.1 [Site](#)

32.1.1 [General](#)

32.1.4 [Site Protection](#)

32.1.2 [Utilities](#)

32.1.5 [Lighting](#)

32.1.3 [Surrounding Areas](#)

32.1.6 [Construction Trailer](#)

### 32.2 [Parking Lots](#)

32.2.1 [General](#)

32.2.4 [Asphalt Cut & Patch](#)

32.2.2 [Standard Lots](#)

32.2.5 [Parking Lot Signage](#)

32.2.3 [Heavy Lots](#)

### 32.3 [Landscaping](#)

32.3.1 [General](#)

32.3.5 [Drainage](#)

32.3.2 [Plantings](#)

32.3.6 [Water Conservation](#)

32.3.3 [Lawns](#)

32.3.7 [Design](#)

32.3.4 [Hydro-Seeding](#)

32.3.8 [Plants to Avoid](#)

### 32.4 [Irrigation](#)

32.4.1 [General](#)

32.4.8 [Heads](#)

32.4.2 [Winterization](#)

32.4.9 [Controller](#)

32.4.3 [Piping](#)

32.4.10 [Electrical](#)

32.4.4 [Pipe Installation](#)

32.4.11 [Mapping](#)

32.4.5 [Valve Boxes](#)

32.4.12 [Inspections](#)

32.4.6 [Valves](#)

32.4.13 [Repairs](#)

32.4.7 [Sleeving](#)

---

## Division 33 – UTILITIES

### 33.1 [Utilities Locating & Tracer Wire](#)

33.1.1 [Utilities Locating](#)

33.1.2 [Tracer Wire](#)

---

## APPENDIX

Appendix A - [Design Guideline Checklist](#)

Appendix B - [Card Reader Details](#)

Appendix C - [Cured-in-Place Pipe Technical Specifications](#)

Appendix D - [Fire Alarm Performance Guidelines](#)

---

# JMU DESIGN & CONSTRUCTION GUIDELINES COMPLIANCE FORM

## RDP/CONTRACTOR COMPLIANCE FORM

JMU Project Name: \_\_\_\_\_

Project Code #: \_\_\_\_\_

Consultant/Contractor Firm Name: \_\_\_\_\_

I, \_\_\_\_\_ (print name), as the registered design professional(RDP)/contractor of the aforementioned project and the authorized agent for the aforementioned firm, do hereby certify that I have read the *JMU Design and Construction Guidelines* in its entirety, have complied with all requirements therein, completed the design guidelines checklist. This includes all general and specific design principles, as well as any included material and equipment specifications and the listed construction drawing requirements. I also certify that any requirements that are unable to be met, for whatever the reason, have been listed in the *JMU Design Standards Variance Form* and submitted to the designated JMU PM. I also understand that any requests for variance from these guidelines must be first approved by either the JMU Director of Facilities Engineering and Construction or the JMU Director Facilities Planning and Construction before being implemented in the project.

RDP/Contractor Signature: \_\_\_\_\_

(Please return this completed form and attach a copy of the completed design guidelines checklist to your JMU PM with the submission of the preliminary drawings.)

### (1.1) General Information

#### 1.1.1 Codes

- 1.1.1.1 The A/E is to adhere to all applicable federal, state and local codes throughout the project.
- 1.1.1.2 This document may provide code references, exclude certain code-approved exceptions or reference sources outside of the typical code; e.g. VDOT standards, etc.
- 1.1.1.3 This document does NOT supersede any required codes, to include, but not limited to:
  - 1.1.1.3.1 The current Virginia Uniform Standard Building Code (VUSBC)
  - 1.1.1.3.2 The Construction & Professional Services Manual (CPSM)
  - 1.1.1.3.3 JMU Higher Education Capital Outlay Manual (JMU HECOM)
  - 1.1.1.3.4 The current National Electrical Code (NEC)
  - 1.1.1.3.5 All other codes or manuals referenced in any of the aforementioned codes

#### 1.1.2 Building and Site Efficiency

- 1.1.2.1 All new construction and renovation shall comply with all current Executive Orders to the extent practicable and where economically justifiable for the university.
- 1.1.2.2 All efficiency measures shall consider the total building and site design and incorporate those measures to give JMU the best possible lifetime payback.
- 1.1.2.3 All building efficiency measures shall consider the projected maintenance requirements and their associated costs into lifetime building costs.
- 1.1.2.4 Focus shall be placed on the cost-efficient reduction of energy demand through building envelope design, while incorporating upwards compatibility for future “free-energy devices;” e.g. PV, wind turbines, etc.

#### 1.1.3 Hot Work and Fire Watch

- 1.1.3.1 Includes all welding, soldering, cutting, brazing, grinding, drilling or other methods of construction or destruction that can produce a potential fire hazard in the presence of flammable material in an occupied building.
- 1.1.3.2 All such work shall require a JMU Hot Work permit before work begins.
- 1.1.3.3 All hot work requires a continuous fire watch that is approved by the JMU office of Risk Management. Fire watch shall also be required in any instance in which a fire suppression system or fire alarm system will be deactivated, modified or limited in its function in any capacity. Certain areas could require an extended fire watch beyond the completion of the hot work.
- 1.1.3.4 The contractor shall provide a minimum of 48 hours of prior notice to the JMU PM for fire watch request.
- 1.1.3.5 Comply with JMU Fire Watch procedures.

#### 1.1.4 Occupied Buildings

- 1.1.4.1 All work involving occupied buildings or sites shall make primary considerations for the safety of those occupants.
- 1.1.4.2 Any work in an occupied building that involves a restriction to the accessible route shall provide an alternate accessible route.

## DIVISION 01 - GENERAL REQUIREMENTS

### 1.1.5 Confined Space

1.1.5.1 All confined space work shall comply with chapter 140 of the Virginia Administrative Code, the “Virginia Confined Space Standard for the Construction Industry.”

### 1.1.6 Inspections

1.1.6.1 The JMU Engineering Project Manager (PM) or FP&C Project Engineer will generally perform project inspections, in keeping with regulations as found in the *CPSM*. However, Facilities Engineering will perform additional periodic inspections of projects. These inspections are for code compliance issues. Facilities Engineering personnel are state certified building and trade inspectors.

1.1.6.1.1 The JMU Engineering Project Manager (PM) or FP&C Project Engineer shall coordinate with the Plumbing Shop during the design phase and after completion of a project to perform a camera inspection of sewer lines both inside and outside the building until the sewer line connects to a main sewer line or manhole to ensure the lines are in good condition.

### 1.1.7 Clean Air Permit Requirements

1.1.7.1 JMU currently operates under a Federal Title V operating permit. This permit classifies JMU as a potentially hazardous air pollutant source and the permit conditions reduce this potential with both practical and federally enforceable measures. Therefore, JMU must closely monitor all stationary polluting equipment that is replaced or installed on JMU property. The submittals and emissions calculations for all such equipment shall be closely reviewed and approved prior to installation, allowing JMU to determine the impact to our current permit. Additionally, all internal combustion engines shall meet the EPA regulations in 40 CFR Parts 40, 85 Standard of Performance for Stationary Compression Ignition Internal Combustion Engines. JMU will be required to submit an Air Permit Application (Form 7) for every piece of stationary polluting equipment that is owned or installed at JMU. This can be submitted as a group for major projects or independently per piece of equipment. The A/E and/or contractor shall submit the required information for all polluting equipment regardless of size. Pollutant sources to be considered are, but not limited to: natural gas, diesel oil, wood, coal or trash.

### (1.2) ARCHITECTURAL

#### 1.2.1 Purpose

**1.2.1.1** This section is designed to provide more specific guidance to the designer as to certain detailed requirements for JMU buildings and site work.

**1.2.1.1.1** At the preliminary design phase of any Capital Outlay Project, color boards shall be presented to the JMU Facilities Planning and Construction Department to be reviewed for the interior and exterior finish materials and their proposed applications. Two (2) copies of the approved color boards are required, one of which will be distributed to the Procurement Office and one to the project committee chair.

**1.2.1.1.2** At the preliminary design phase of any Non-Capital Outlay Project, color boards shall be presented to the JMU Engineering and Construction Department to be reviewed for the interior and exterior finish materials and their proposed applications. Three (3) copies of the approved color boards are required, one of which will be distributed to the Procurement Office, one to the project committee chair and one to Engineering and Construction for record.

#### 1.2.2 Site Design

**1.2.2.1** Building placement shall comply with all applicable master plans, design reviews, fire and service accessibility requirements.

**1.2.2.2** Building shall be oriented and sites designed to make connection to adjacent building's site circulation and/or public ways.

**1.2.2.3** All infrastructure and delivery of utilities or services shall be included as an integral part of the project.

**1.2.2.4** All loading docks, mechanical equipment and other utilitarian areas shall be designed to fit within the campus context. Screening shall be included in the design of any such element.

#### 1.2.3 Building Design

**1.2.3.1** Design massing and volumes to respect and respond to visually adjacent existing buildings.

**1.2.3.2** Design the building to maximize the number of rooms with natural daylight exposure, while minimizing the ratio of surface area of walls and roofs, to the gross building area, to reduce heat loss and/or gain.

**1.2.3.3** Design roofs to shed snow, ice, and rain in a controlled manner away from the egress path of building occupants. All entries and exits shall be protected from snowfall by their specific roof design, not by roof or entry level barriers.

**1.2.3.4** Pitched roofs with overhangs shall be used wherever practicable for lifetime maintenance and durability reasons.

**1.2.3.5** Orient primary egress paths, mechanical intakes and mechanical discharges with respect to prevailing weather patterns. Buffer all entries through the use of vestibules. Shield all mechanical entries from moisture, snow or frost intrusion through the use of orientation and of plenums, freeze proof preheat coils or other means.

## DIVISION 01 - GENERAL REQUIREMENTS

- 1.2.3.6 Cantilevered steel or concrete beams shall be avoided to minimize thermal bridging.
- 1.2.3.7 All buildings shall be constructed of minimal maintenance materials; e.g. brick, concrete masonry units, precast concrete, etc and follow the color pallet of adjacent buildings
- 1.2.3.8 Building entries shall utilize airlocks to minimize air and dust intrusion.
- 1.2.3.9 Building design shall incorporate the use of overhangs and other architectural features to protect exterior walls and openings from the elements wherever practicable.
- 1.2.3.10 All exposed structural and mechanical elements, beams, columns, rain leaders, etc., that are visible from public areas, shall integrate with the overall building aesthetic. Exposed structural elements shall be used only with the specific prior approval of the Director of Facilities Planning & Construction.

### 1.2.4 Acoustics

- 1.2.4.1 All renovations and new construction shall be designed to comply with requirements and recommendations of "ANSI/ASA S12.60-2010/Part 1 American National Standard Acoustical Performance Criteria, Design Requirements, and Guidelines for Schools, Part 1: Permanent Schools." A/E shall, by submitting preliminary design documents for approval and again by stamping and signing construction documents, stipulate full compliance of the design and full inclusion of all necessary conformance testing for each and every space in the authorized commissioning plan. Designing to and testing conformance of the performance of building spaces and systems is part of basic design services.
- 1.2.4.2 Installation of noise-generating devices (telephone, vending machines, etc.) should be avoided on the adjoining walls between any rooms requiring acoustical privacy. Such devices shall not be located in common hallways or corridor areas adjacent to noise sensitive areas.
- 1.2.4.3 Back-to-back utility installations shall be avoided. Place these installations a minimum of one stud bay apart to minimize sound transmission.
- 1.2.4.4 All walls shall be acoustically insulated and finished with gypsum board from the floor to the deck above. Insulation must fill all voids.
- 1.2.4.5 Required acoustical isolation shall extend behind recessed fixtures of any type; e.g. medicine cabinets, fire extinguisher cabinets, electric panels, drinking fountains, bookcases, etc.

### 1.2.5 Security Control Rooms

- 1.2.5.1 Security rooms shall be provided to house and protect the main control equipment for required life safety systems; e.g. fire alarms, security systems, card readers and surveillance/security cameras.
- 1.2.5.2 Provide one security room per building. For multistory buildings coordinate with JMU Project Manager for additional security room requirements prior to the completion of the Preliminary Design phase.
- 1.2.5.3 Each security room shall a minimum of 100ft<sup>2</sup>.
- 1.2.5.4 There shall be no accessory use of the room permitted without prior approval.
- 1.2.5.5 The security room on each floor shall be interconnected and vertically aligned with the security room(s) above and below.

## DIVISION 01 - GENERAL REQUIREMENTS

- 1.2.5.6 The interconnection shall be (3) 4" conduit runs not to exceed 25' in length. Each conduit run shall also be provided with no less than one additional pull string that is clearly marked.
- 1.2.5.7 Each security room shall be provided with two (2) communications outlets.
- 1.2.5.8 Each security room shall be provided with a minimum of three (3) separate electrical circuits, with each circuit rated at a minimum of 20 amps.
- 1.2.5.9 All security rooms shall be supplied with emergency lighting and power.

### 1.2.6 Security Classifications

1.2.6.1 **Level One** (*public and semi-public spaces*) - This classification applies to public spaces with intense traffic and no clear ownership definition; e.g. areas without card access or otherwise locked entry doors, lobbies, unrestricted corridors, vestibules, classrooms, stairs, elevators, public restrooms, food service facilities, bookstores, recreational and parking facilities, assembly areas and conference rooms. The following minimum security measures are required for *Level One* spaces:

- 1.2.6.1.1 Clearly posted hours of operation
- 1.2.6.1.2 Well-lit entries, lobbies and corridors
- 1.2.6.1.3 High visibility into spaces before entering
- 1.2.6.1.4 Doors lockable by only JMU maintenance staff or JMU police.
- 1.2.6.1.5 Visibility from adjacent occupied spaces
- 1.2.6.1.6 Emergency telephones linked to JMU police
- 1.2.6.1.7 Easily identifiable and accessible egress paths
- 1.2.6.1.8 Fire and smoke alarm systems

1.2.6.2 **Level Two** (*private and locked semi-public spaces*) - This classification applies to parts of a facility may be secured by locked doors, areas where traffic flow is smaller and more controlled and more valuable equipment and/or risk factors are involved. Examples of private spaces at this level include faculty & staff offices, teaching labs, exercise facilities, health and safety areas, lecture hall preparation areas, projection booths, dark rooms, private toilets, special collection areas, campus operation and maintenance spaces, building mechanical/electrical/telecommunication spaces, etc. In addition to security measures recommended for level one, these areas should include the following:

- 1.2.6.2.1 Secured doors with inside vandal-proof or pinned hinges and latch guard.
- 1.2.6.2.2 Lockable windows.
- 1.2.6.2.3 Controlled/programmable keying system.
- 1.2.6.2.4 Non-lift sliding windows or doors (if used).

1.2.6.3 **Level Three** (*secure spaces*)-This level applies to high equipment holding spaces, special collection areas, high exhibit spaces, supply rooms, computer mainframe rooms, special secure areas, confidential file rooms, vaults, etc. The security requirements for these spaces shall be determined on a case by case basis, but as a general rule of thumb, the following shall be considered in addition to all security features noted for levels one and two:

- 1.2.6.3.1 Motion sensors.
- 1.2.6.3.2 Intrusion alarms.
- 1.2.6.3.3 Electronic surveillance.

## DIVISION 01 - GENERAL REQUIREMENTS

- 1.2.6.3.4 Time clock access restrictions.
- 1.2.6.3.5 Security guard/patrol intervals.
- 1.2.6.3.6 Special ID detection/access system.

### 1.2.7 Exterior security

- 1.2.7.1 The protection of people and vehicles at building exteriors is extremely important. Security at walkways, entries, loading and unloading areas, near ground floor windows, and at building indentations can be significantly enhanced by applying the same principles followed in the design of other public spaces.

### 1.2.8 Card Readers

- 1.2.8.1 In all new and remodeled buildings, install one labeled, 2" empty conduit from building telecommunication room to main electrical room.
- 1.2.8.2 For all building entrances and computer laboratories, provide a 4" square box, with a single gang plastic ring, served by ¾" conduit to the security control room. Label conduit for use with a future card reader system. Mount boxes on strike side of each entrance. This is in addition to all the required infrastructure for security, resultant emergency existing devices, electric strikes, etc.

### 1.2.9 Custodial Areas

- 1.2.9.1 One custodial closet shall be provided per 10,000ft<sup>2</sup> of floor area, per story, for every story of new buildings. When multiple closets are required per story, provide a minimum distance of 300' feet between closets.
- 1.2.9.2 Custodial closets should be located near elevators and restrooms, and centralized among the areas they will serve. Do not locate custodial closets on stairway landings.
- 1.2.9.3 Entrances to custodial closets through restrooms, mechanical rooms or similar intermediate spaces or vice versa are not permitted.
- 1.2.9.4 The typical custodial closet floor needs to be a minimum of 80ft<sup>2</sup> with no less than an 8' dimension in any direction, with a minimum clear ceiling height of 9'.
- 1.2.9.5 Do not locate the components of any telecommunications, electrical or mechanical systems in custodial closets. Closets shall be dedicated to custodial functions only. Accessory roof hatch access shall be permitted.
- 1.2.9.6 A large capacity Terrazzo floor sink with stainless steel rim, stainless steel splash protectors, hot, cold and tempered running water and a floor drain shall be provided in each custodial closet. Sinks are best located near the door, and should be positioned so that cleaning machines and equipment can be maneuvered easily and emptied into the sink prior to being refilled. 4' high FRP paneling wainscot minimum 4' each side of the centerline of the sink. Blocking shall be provided at the wall beside the floor sink for chemical dispenser.
- 1.2.9.7 All fixtures used to supply hot and cold water in a combined outlet shall include check valves for both hot and cold supply lines to prevent hot/cold cross connection when an accessory is attached to the outlet. This may be accomplished by either of adding in-line check valves leading to the fixture in an access panel, or by installing fixtures with integral, field replaceable check valve "cartridges" on both the hot and cold supply valves. Fixtures that include a single combined check valve for the outlet do not satisfy this requirement.

## DIVISION 01 - GENERAL REQUIREMENTS

- 1.2.9.8 Provide shelving on at least 3 walls for a minimum of 15 lineal feet, each with a minimum of a 14" vertical clearance between shelves. Mop hangers, mop racks, hose racks and broom racks shall also be provided. Blocking shall be provided for all shelves and location is to be coordinated with the building owner.
- 1.2.9.9 In addition to the wet custodial closet, a 120ft<sup>2</sup> custodial supply storage room shall be provided for each building. This room should be located in proximity to the elevator.
- 1.2.9.10 In addition to, or in conjunction with the custodial supply storage room, each facility shall be provided with a custodial staff area. This area shall include lockers, a table, chairs, a sink, cabinetry, countertops, walls
- 1.2.9.11 at least one receptacle outlet for countertop equipment, a bulletin board and a wall clock. Size and location of the area shall be verified and confirmed by the project manager.
- 1.2.9.12 Provide a 36" door that opens outward, not to restrict any code-required emergency egress paths.

### 1.2.10 Equipment Rooms

- 1.2.10.1 At each mechanical, electrical, elevator, substation or penthouse equipment room, provide at least one (1) communications outlet with adjacent 125 volt GFCI duplex outlet and one (1) wireless access point.
- 1.2.10.2 Equipment room layouts shall indicate graphically how servicing, operation and repair clearances are assigned. These graphic representations shall include all necessary carrying beam, crane and/or pick-point locations.
- 1.2.10.3 Provide a minimum of a 4" housekeeping pad for all floor-mounted equipment.
- 1.2.10.4 Locate all equipment to provide an ample and clearly defined circulation path for the safe removal, repair and replacement of all equipment. Provide all necessary structural and finish elements needed to allow for the movement of associated devices and equipment.
- 1.2.10.5 Access to equipment rooms shall be through the use of full height doors and/or direct staircases from the exterior or main corridor. Equipment room egress paths shall be clearly diagrammed on preliminary drawings.
- 1.2.10.6 Rooms and their access routes shall be designed to allow the largest piece of equipment to be removed and replaced without having to remove any permanent walls or other large, functioning equipment.
- 1.2.10.7 Equipment rooms shall include mechanical system thermal insulation and ventilation provisions such that ambient temperatures in the room rise no more than 10 degrees above outside ambient temperatures.
- 1.2.10.8 Prior to building acceptance, all HVAC equipment housed in the building shall be placed in normal operational status for at least 24 hours, and a thermal imaging survey shall then be conducted on all interior building wall, ceiling and floor surfaces adjacent to equipment rooms to ensure thermal leakage is not occurring. In areas where thermal leakage is found, additional insulation must be added to thermally isolate the system(s) and/or the equipment room from the interior spaces. In situations where the addition of insulation is not feasible, additional ventilation provisions shall be added to the equipment room instead.

## DIVISION 01 - GENERAL REQUIREMENTS

### 1.2.11 Telecommunication Rooms

1.2.11.1 See Division 27.

### 1.2.12 Maintenance Rooms

1.2.12.1 Every new building or major remodel project shall include a maintenance material storage room.

1.2.12.2 Rooms shall be 100ft<sup>2</sup>, with no less than a 7' dimension in any direction and shall have a minimum of a 9' clear ceiling height.

1.2.12.3 Each room shall have a minimum of a 36" wide entry door.

1.2.12.4 Locate the maintenance materials storage room near the service entry.

1.2.12.5 Semi-gloss paint is a minimum wall finish.

### 1.2.13 Laundry Rooms

1.2.13.1 Shall be designed so that routine maintenance shall be able to be performed without having to move the unit or any adjacent units.

### 1.2.14 Lactation Rooms

1.2.14.1 Every new building or major remodel project shall include a lactation room.

1.2.14.2 The room shall have a lockable door, with a sink and a counter. The under-counter space shall be able to accommodate a mini refrigerator and have convenience receptacles available. Any windows shall have blinds.

### 1.2.15 Trash/Recycling Rooms

1.2.15.1 A recycling room of approximately 100ft<sup>2</sup> shall be provided in each facility, with no dimension less than 7' allowed in any direction. This room shall be located near the loading/service area.

1.2.15.2 All trash and recycling areas shall be sheltered from the wind and easily accessible by custodial staff. Locations shall consider the unpleasant odors often generated by these spaces. Approved screening is required in all trash collection areas.

1.2.15.3 Provide hot and cold hose bibs with backflow prevention, floor drains and impermeable floor and wall coverings.

### 1.2.16 Loading Areas

1.2.16.1 All new facilities shall be provided with adequate off-street service loading and unloading areas.

1.2.16.2 Loading facilities shall allow the use of multiple scales of delivery. Access shall be provided on grade or with ramps for hand truck or cart deliveries to the loading area.

1.2.16.3 Interior and exterior staging, packaging, unpacking and temporary storage areas for loading and unloading shall be included in all facilities.

1.2.16.4 Truck cargo door loading bays shall provide inflatable air sealing devices to account for varying truck dimensions and provide full weather protection.

1.2.16.5 Truck loading bays shall be 48" above grade and incorporate truck levelers when necessary.

1.2.16.6 One (1) communications outlet shall be placed at the entrance of loading areas for delivery drivers to notify JMU personnel of a delivery.

## DIVISION 01 - GENERAL REQUIREMENTS

### 1.2.17 Offices

- 1.2.17.1 Faculty and managerial level staff office areas shall include space and services to allow provisions for an L-shaped desk, a 36" wide lateral file and/or bookcase, and a 48" square white board and two guest chairs.
- 1.2.17.2 Each office shall have a minimum of two (2) power receptacle outlets on opposing walls.
- 1.2.17.3 Each office shall have a minimum of two (2) communications outlets on opposing walls for each 100ft<sup>2</sup> of space and one (1) additional communication outlet for each additional 100ft<sup>2</sup>, or portion thereof, for telephone, data and video.
- 1.2.17.4 No office floor plan dimension shall be less than 9'.

### 1.2.18 Instructional Spaces

- 1.2.18.1 Lighting shall be designed to allow presentation on white boards and projection screens with concurrent note taking and fully lit classroom functions.
- 1.2.18.2 General-purpose classroom equipment shall include, but not be limited to, the following:
  - 1.2.18.2.1 Instructor area desk and podium with A/V connection, power and communications outlet
  - 1.2.18.2.2 Fully-seasoned chalkboards, "smart boards" and/or marker boards
  - 1.2.18.2.3 Tackable display surfaces
  - 1.2.18.2.4 Student seating (verify type and orientation on a room-by-room basis)
  - 1.2.18.2.5 Trash and recycling receptacles near the classroom
  - 1.2.18.2.6 Motorized retractable projection screen or Flatscreen as required by and coordinated with JMU IT/AV staff.
  - 1.2.18.2.7 Wall Clock
  - 1.2.18.2.8 Communications outlets with adjacent power outlets (verify quantities and locations on a room by room basis)
  - 1.2.18.2.9 Ceiling mounted data/video display unit, associated infrastructure and associated voice augmentation
  - 1.2.18.2.10 General purpose electrical outlets for both operation and maintenance  
A minimum of one room in every building shall be provided with distance learning equipment infrastructure. This infrastructure shall include space availability, system capability, structural capacity and pathways of cameras, control/operation areas monitors, projection devices, etc.

### 1.2.19 Restrooms

- 1.2.19.1 All new buildings shall have a single-user, unisex "Family Restroom" installed on the main egress floor, as well as at least one on alternate floors thereafter.
- 1.2.19.2 Direct and/or reflected lines of sight into all restrooms shall be broken.
- 1.2.19.3 A minimum of one (1) GFCI receptacle outlet shall be installed near the sink area in all restrooms.
- 1.2.19.4 Lighting shall be provided above all enclosed stalls.
- 1.2.19.5 All wall mounted fixtures and accessories shall be of stainless steel or have a high quality baked-on finish. Some rooms may require full plywood backing behind sheetrock. Verify each rooms specific requirements with the JMU PM.

## DIVISION 01 - GENERAL REQUIREMENTS

- 1.2.19.6 Provide a lead-free ceramic tile wall covering and/or high-gloss enamel finished wainscoting at a minimum height of 54" above finished floor height in all restrooms.
- 1.2.19.7 All lavatories, toilets (elongated bowl only) and urinals shall be solid white ceramic. All toilets shall have open-front, heavy plastic seats with self-sustaining, stainless steel hinges.
- 1.2.19.8 Floors shall be lead-free ceramic tile with dark epoxy grout. An uncoupling membrane shall be provided between the tile and the subfloor.
- 1.2.19.9 All shower surrounds and toilet partitions shall be fully detailed, providing all fabrication and installation details.
- 1.2.19.10 All toilet partitions shall be solid plastic.
- 1.2.19.11 Restrooms, bathrooms and shower areas shall be constructed with watertight floor/wall systems with integral floor drains and shall water-tested by JMU inspector. Waterproofing systems shall be a minimum of 40mil PVC liner or be verified to offer greater protection.
- 1.2.19.12 Floor drains shall be equipped with passive, self-priming devices.
- 1.2.19.13 Provide floor mounted toilet fixtures.
- 1.2.19.14 Sanitary napkin disposal containers shall be provided in all stalls of women's and companion restrooms.
- 1.2.19.15 Hand dryers to be reviewed and approved by Director of Facilities Planning and Construction prior to completion of Preliminary Drawings. At hand dryer locations, provide solid surface or stainless-steel sheet same width of hand dryer, 24" tall from the blower location of the hand dryer.
- 1.2.19.16 JMU shall supply all soap, toilet tissue, sanitary napkin and paper towel dispensers to be installed by the contractor.
- 1.2.19.17 Per the CPSM 7-1-2020, provide ADA compliant baby changing stations in all restrooms adjacent to areas of public assembly, and a minimum of one for both male and female restrooms, per story. Additionally, one baby changing facility is required in all family or assisted-use bathrooms.
- 1.2.19.18 All restrooms must be designed to meet the Department of Justice ADA Standards for Accessible Design.
  - 1.2.19.18.1 Vertical grab bars shall be provided in accordance with the CPSM 7-1-2020 and the ICC A117.1 as referenced by the 2015 Virginia Construction Code.

### 1.2.20 Lobbies

- 1.2.20.1 Building egress shall be through centrally located, enclosed and lockable lobby areas.
- 1.2.20.2 Provide a Terrazzo-floored vestibule at all exterior doors on the story serving the level of exit discharge. All non-recessed floor mats provided by JMU building owner.
- 1.2.20.3 The building lobby shall contain a building directory and a lockable bulletin board.
- 1.2.20.4 Provide terrazzo flooring at all lobbies and, at a minimum, all floor areas serving the main egress path.
- 1.2.20.5 Egress doors shall be recessed or protected by canopies and wing walls.
- 1.2.20.6 Provisions shall be made to provide safe and maintenance-friendly access to all lighting fixtures in lobbies, atriums and other such high-ceiling, high-volume spaces.

### 1.2.21 MSDS

## DIVISION 01 - GENERAL REQUIREMENTS

**1.2.21.1** Material Safety Data Sheets (MSDS) for all materials used in the project shall be submitted to the university with the construction documents in accordance with federal regulations.

### 1.2.22 Stairwells

**1.2.22.1** Exit Stairs - The use of rubber tread covers with integral risers, stringer skirts and/or rubber flooring at landings are preferred. Substitutions shall be reviewed and approved by JMU prior to the end of the Preliminary Design phase.

**1.2.22.2** The design and construction of “Grand” or “Communicating” stairs are required to be reviewed and approved by JMU prior to the end of the Preliminary Design phase.

**1.2.22.3** Stairwell labels shall use lettered designations and be arranged in a logical and alphabetical fashion.

**1.2.22.4** Stairwell labels shall indicate at every level the following items:

**1.2.22.4.1** Roof access

**1.2.22.4.2** Level of exit discharge

**1.2.22.4.3** Current story level out of total stories

### 1.2.23 Vending Machines

**1.2.23.1** Vending machines shall not be located in corridors. Where vending machines are authorized, the A/E shall design all appropriate power, water, drains and a communications outlet.

**1.2.23.2** All vending machines shall be *Energy Star* rated.

### 1.2.24 Bicycle Racks

**1.2.24.1** Campus racks are being standardized to the “Inverted-U” style. Coordinate with JMU PM as to the space requirements for bicycle racks.

**1.2.24.2** Provide bicycle rack space to account for 5% of the peak building or space occupant load.

**1.2.24.3** Provide adequate space for bicycle racks within 50’ of the main entry door.

**1.2.24.4** Coordinate with JMU PM as to whether bicycle racks will be contractor or JMU provided and installed.

**1.2.24.5** Whenever possible, provide racks in a covered area and convenient to area bicycle paths.

### 1.2.25 Mail Rooms

Consideration for mailrooms shall be addressed with the JMU PM and the Mail Services director in the preliminary design phase.

### 1.2.26 Numbering

**1.2.26.1** Numbering and labeling of buildings, rooms, stairwells and any other related features shall be approved by JMU at the preliminary design stage.

**1.2.26.2** Room numbers and labeling shall use the SCHEV standard.

### 1.2.27 Fire Pits

**1.2.27.1** ALL FIRE PITS MUST BE APPROVED BY THE EXECUTIVE DIRECTOR OF FACILITIES PRIOR TO INSTALLATION.

## DIVISION 01 - GENERAL REQUIREMENTS

- 1.2.27.2 All fire pit design and installation must be permitted through the Virginia Division of Engineering and Buildings and the State Fire Marshall.
- 1.2.27.3 Fire pits are not allowed on the Campus Quad.
- 1.2.27.4 Fire pits are not allowed adjacent to Auxiliary facilities.
- 1.2.27.5 Requesting department must identify a responsible person for the general safety of the fire pit and is located in the building adjacent to the fire pit installation.
- 1.2.27.6 All fire pits must contain a NTRL rating and meet ANSI Z21.97 and ANSI Z21.20 standards.
- 1.2.27.7 All fire pits must be located 30 feet from an adjacent structure.
- 1.2.27.8 All fire pits need to be fueled by natural gas or propane with stone or glass rock, wood burning fire pits are not allowed.
- 1.2.27.9 All fire pits are to be controlled by a timer only activated between 7:00 am-11:00 pm and have a lockable valve, electric igniter, and emergency shutoff at the fire pit and adjacent building.
- 1.2.27.10 All fire pits are to be constructed with masonry, the finish is to match the masonry finish of the adjacent building and have a nonremovable spark cover.
- 1.2.27.11 All fire pits shall not be located adjacent to any trees.
- 1.2.27.12 All fire pits shall be located in a public place and have a minimum of (1) security camera giving coverage of the fire pit area.

### 1.2.28 Gas Fireplaces

- 1.2.28.1 ALL GAS FIREPLACES MUST BE APPROVED BY THE EXECUTIVE DIRECTOR OF FACILITIES PRIOR TO INSTALLATION.
- 1.2.28.2 All fireplace design and installation must be permitted through the Virginia Division of Engineering and Buildings and the State Fire Marshall.
- 1.2.28.3 Fire pits are not allowed in Auxiliary facilities.
- 1.2.28.4 All gas fire places must contain a NTRL rating and meet ANSI Z21.88 and ANSI Z223.1 standards.
- 1.2.28.5 All gas fire places need to be fueled by natural gas or propane with ceramic logs, stone or glass beads and include a glass front safety barrier, wood burning fire places are not allowed.
- 1.2.28.6 All gas fire places are to be direct vent.
- 1.2.28.7 All gas fire places are to be controlled by either a timer or switch and have a lockable valve, emergency shutoff and an electric igniter.

### (1.3) ABATEMENT

#### 1.3.1 Scope

**1.3.1.1** The JMU Facilities Engineering and Construction Department (FE&CD) will always monitor any and all aspects of hazardous waste procedures. The JMU FE&CD will delegate the responsibility of hazardous or other waste inspections and the subsequent provisions for environmental remediation or removal *prior* to any construction in existing or new buildings to either the A/E, the general contractor or to JMU. Hazardous waste removal information will be provided to the A/E throughout the design phase of the project as needed for work performed by JMU. The A/E shall incorporate the following information into the construction drawings of the project:

#### 1.3.2 Asbestos

**1.3.2.1** “An asbestos inspection was performed and no ACM’s were found.”

**1.3.2.2** “An asbestos inspection was performed and ACM’s were found generally in the areas indicated. However, the work in this project is not intended to disturb the existing ACM’s.”

**1.3.2.3** “An asbestos inspection was performed and asbestos-containing materials were found generally in the areas indicated. The asbestos survey/inspection report is available to the contractor(s) for his information. The ACM’s shall be removed prior to any other work being performed in these areas. The Asbestos Management Plan (AMP) is included in the documents. The asbestos abatement contractor shall mark-up the AMP to show the “as-built” conditions resulting from its work to include the areas where asbestos was abated, the areas where asbestos was encapsulated and the areas where ACM’s exist, but were left in place.”

**1.3.2.4** “An asbestos inspection was performed and ACM’s were found generally in the areas indicated. The asbestos survey/inspection report and the AMP area available to the contractor(s) for demolition and for construction for their information. ACM’s shall not be disturbed in this work, except where specifically indicated and required for connections to utilities. Where such connections are required, the contractor shall have the obstructive and adjacent ACM’s removed by a licensed abatement contractor using approved procedures as specified. The ACM’s that are to remain, and the new non-ACMs, shall be labeled accordingly. The abatement contractor shall mark-up the AMP to show the “as-built” conditions resulting from its work to include the areas where asbestos was abated, the areas where asbestos was encapsulated and the areas where ACM’s exist, but were left in place.”

#### 1.3.3 Lead Paint

**1.3.3.1** “A lead-based paint inspection was performed and no lead-based paint was found.”

**1.3.3.2** “A lead-based paint inspection was performed and lead-based paint was found in indicated areas. However, the work in this project is not intended to disturb existing lead-based paint.”

**1.3.3.3** “A lead-based paint inspection was performed and lead-based paint was found in the areas indicated. The lead-based paint shall be removed prior to any other work being

## DIVISION 01 – GENERAL REQUIREMENTS

performed in these areas. The contractor shall be responsible for compliance with all requirements of the Virginia Occupational and Health Administration regulations regarding lead-based paint protection for workers”

- 1.3.3.4** “A lead-based inspection was performed and lead based paint was found in the areas indicated. Lead-based paint shall not be disturbed in this work except where specifically indicated and required for connections to utilities. Where such connections are required, contractor shall have the obstructive and adjacent lead-based paint removed by a licensed lead-based paint abatement contractor using approved procedures as required by VOSHA. The lead-based paint that remains and new non lead-based paint areas shall be labeled accordingly.”

### **1.3.4 Other Material**

- 1.3.4.1** All environmental remediation and/or removal of all other waste materials shall conform to their applicable federal, state and local laws.

### (1.4) CONSTRUCTION DRAWINGS

#### 1.4.1 General

- 1.4.1.1 All drawings prepared for projects within JMU Main Campus boundaries shall be tied to the JMU Survey Control Network. Drawings shall show JMU control network point used in addition to project specific control points established by the project Surveyor. All drawings shall have the meridian based on the JMU Survey Control Network. JMU will provide control point information within the project area. The JMU Survey Control Network is based on Virginia State Plane Grid System, North Zone, U.S. Survey Foot. Horizontal control is NADA83-CORS96-EPOCH2002.0000. Vertical control is NAVD88 (geiod03) U.S. Survey Foot.
- 1.4.1.2 For projects outside of JMU Main Campus boundaries, it shall be the responsibility of the A/E to establish control points within the project area. All control points established shall be based Virginia State Plane Grid System South Zone U.S Survey Foot. Horizontal control shall be NAD83-CORS96-EPOCH2002.0000. Vertical control shall be NAVD88 U.S. Survey Foot.
- 1.4.1.3 FM does not loan drawings of any type. The engineering drafting department will make one copy of any required drawings to assist the A/E. Additional copies shall be the responsibility of the A/E and/or the contractor. Any requests for copies of drawings shall be coordinated through the JMU PM. Electronic drawings will be provided if available.
- 1.4.1.4 Two (2) sets of approved full construction drawings and specifications shall be submitted to JMU at the beginning of the project.
- 1.4.1.5 Provide a digital copy of each phase of the plans in PDF format, in addition to the required hard copies.
- 1.4.1.6 All project specifications shall be provided in PDF format (preferred) or in the most current version of Microsoft Word for windows format.
- 1.4.1.7 Current bid documents are to be dated with the actual date of final submission incorporating the review comments by applicable university reviews.
- 1.4.1.8 All drawings shall include the following details:
  - 1.4.1.8.1 Point Number
  - 1.4.1.8.2 Northing
  - 1.4.1.8.3 Easting
  - 1.4.1.8.4 Description
  - 1.4.1.8.5 Elevation
- 1.4.1.9 Each drawing shall have a note described how project values were established; e.g. ground traverse, GPS, etc.
- 1.4.1.10 All electronic drawing data provided to JMU shall be based on Virginia State Plane Grid System, North Zone, U.S. Survey Foot and shall meet all requirements listed above. All drawings are to be provided to JMU in AutoCAD 2017 format (or format compatible with JMU current version) v. Data shall be provided by client to JMU on CD (or other pre-approved methods).

#### 1.4.2 Drawing Formats

## DIVISION 01 – GENERAL REQUIREMENTS

- 1.4.2.1 AutoCAD™ versions 2017 through 2025 are the only acceptable file formats for drawing submission to JMU. Data Interchange Files (.DXF files) will not be accepted as an alternative. If project drawings are created using a computer aided drafting and design program other than AutoCAD™, the consultant shall be responsible for any conversion procedures necessary to generate acceptable AutoCAD™ files for submission to JMU. The consultant shall also be responsible for maintaining accuracy and inclusion of all items within the drawings during the translation process. (See Sections 5.4, 5.5 and 5.6 for specific details).
- 1.4.2.2 Renaming the file extension from the original format (i.e. .DXF, .DGN, etc.) to an AutoCAD™ format (.DWG) will not convert the drawing.
- 1.4.2.3 Custom menus or “arx” applications are not allowed if it creates a requirement for the drawing to be used. No menus, custom user interface (cui) files or arx applications are to be submitted.
- 1.4.2.4 BIM models shall be submitted in Revit .RVT format, release 2017 to 2025.

### 1.4.3 CAD Standards

- 1.4.3.1 AutoCAD™ files should not contain more than one drawing sheet per file (.dwg), either by multiple drawings in model space or spread out across several layouts. While this may facilitate the production of construction documents, it can impede the archival process, and create content discrepancies.
- 1.4.3.2 AutoCAD™ files containing multiple drawing sheets shall be broken down into single sheets prior to delivery to JMU.
- 1.4.3.3 AutoCAD™ files delivered to JMU shall contain only one drawing and one title block per file.
- 1.4.3.4 Each CAD drawing should represent a single printed sheet where the file name conspicuously identifies the sheet number (e.g., sheet A2.1 CAD file name might be A2.1.dwg).

### 1.4.4 CAD Drawing Structure

- 1.4.4.1 One folder per discipline, by discipline name (Civil, Landscape, Architecture, etc.).
- 1.4.4.2 All AutoCAD™ files shall be purged of empty, unused, or non-essential drawing data prior to submittal to JMU. This includes the removal of all unused layers, line type, blocks, fonts, dimension styles, and other entities. Unused objects and entities contained in the drawing shall directly apply to the specific purpose of the drawing with the exception of the title block.
- 1.4.4.3 AutoCAD™ files submitted to JMU shall not contain any frozen layers. Unused entities on frozen layers should be erased, the empty layers purged, and all layers thawed.
- 1.4.4.4 AutoCAD™ files shall not contain multiple overlaid lines or lines with multiple segments unless the overlaid lines or adjacent line segments are assigned to different layers. Multiple overlaid lines or blocks can be removed from the drawing by using the “OVERKILL” command.
- 1.4.4.5 Survey data shall be included in the AutoCAD™ files and placed on the appropriate layers.

### 1.4.5 BIM Standards:

- 1.4.5.1 If BIM is required, all CAD drawings shall be exported from Revit. The BIM model shall reflect all as built characteristics, materials, devices, families, etc.

### 1.4.6 Portable Document Format (PDF) Requirements:

- 1.4.6.1 All documents are to be created as PDF files from the original source files, unless approved otherwise in writing by Owner. PDF files shall reside in a folder below the CAD files folder, labeled as “PDF.”
- 1.4.6.2 The CAD printer shall be Autodesk DWG to PDF.pc3 print configuration.
- 1.4.6.3 Layer information shall not be included.
- 1.4.6.4 All documents are to be created with a resolution of not less than 300dpi. All fonts are to be embedded in the PDF.
- 1.4.6.5 When compression is used, the algorithm shall be LZW, CITT group 4 or Packbits. The PDF document size shall be the same as the original document size if the document were printed; e.g., a 24”x36” print should have a PDF sheet size of 24”x36”.
- 1.4.6.6 Each document shall be submitted as a single file.

### 1.4.7 Layering Standards

- 1.4.7.1 JMU layering standards are based upon the United States National CAD Standard® - Version 5 that includes the AIA CAD Layer Guidelines. For more detailed layering information and helpful background material visit their website at <http://www.nationalcadstandard.org/ncs5/>.

### 1.4.8 AIA Layering Format

- 1.4.8.1 Layer names may be as short as 6 characters (discipline code + major group) or as long as 16 characters (discipline code + major group + minor group + status). The following are the four examples of acceptable formula variations, with explanations of the formula variables:
  - 1.4.8.1.1 A-WALL = discipline code + major group
  - 1.4.8.1.2 A-WALL-FULL = discipline code + major group + minor group
  - 1.4.8.1.3 A-WALL-DEMO = discipline code + major group + status code
  - 1.4.8.1.4 A-WALL-FULL-DEMO = discipline code + major group + minor group + status

### 1.4.9 Lines, Objects And Entity Properties

- 1.4.9.1 AutoCAD™ entities are created using these standards:
  - 1.4.9.1.1 Entity colors shall be defined by layer, not entity.
  - 1.4.9.1.2 All lines, objects, blocks and entities shall be drawn where the Z-axis is 0 (zero), meaning there is no elevation to the elements in the drawing and the drawing is truly 2-dimensional.

### 1.4.10 Scale and Units

- 1.4.10.1 All objects are to be drawn at full scale for the assigned unit of measure.
- 1.4.10.2 All drawings are to have a unit of measure assigned and not set to “unitless.”
- 1.4.10.3 Do not use 3/16”=1’-0” and 3/32”=1’-0” units of scale.
- 1.4.10.4 Do not override dimensions.

### 1.4.11 Model And Paper Space Usage

- 1.4.11.1 Place title blocks, schedules and general notes at full-scale (1:1) in paper space.
- 1.4.11.2 Do not place or draw model-related blocks, tags and objects in paper space.
- 1.4.11.3 Scale objects using paper space viewports. Zoom viewports to the appropriate scale.

## DIVISION 01 – GENERAL REQUIREMENTS

### 1.4.12 External References (XREFs)

- 1.4.12.1 AutoCAD™ drawings shall not contain any XREF's prior to submittal.
- 1.4.12.2 External references (excluding drawings, .DWG) shall be inserted into the drawing as a block prior to submittal.
- 1.4.12.3 XREF blocks shall be exploded and the resulting objects placed on the appropriate layer.
- 1.4.12.4 All drawings containing other drawings as an XREF should bind the external referenced drawing into the main drawing. This shall be done using the "Insert" bind type.
- 1.4.12.5 File translation from non-AutoCAD™ systems resulting in wall blocks within AutoCAD™ are unacceptable.
- 1.4.12.6 The "eTransmit" command can be used to ensure all dependent files are included.

### 1.4.13 AutoCAD Drawing Support Files

- 1.4.13.1 Only native AutoCAD™ fonts, line types and hatch patterns, or the approved CAD symbolism provided by the AIA CAD Standards, is acceptable.
- 1.4.13.2 Custom fonts, line types and hatch patterns, including those provided by 3<sup>rd</sup> party software, are not acceptable.
- 1.4.13.3 Postscript fonts shall not be used.

### 1.4.14 File Transmittal

- 1.4.14.1 The content of electronic drawings provided by the architect/engineer shall match the delivered original hard copy set as closely as possible.

### 1.4.15 Error-Free AutoCAD Drawing Deliveries

- 1.4.15.1 JMU recognizes that many of its vendors do not use our same CAD system. However, the University expects the vendors who work with non-AutoCAD™ file formats to submit ".DWG" formatted CAD files upon project closeout that are fully compliant with all of the standards outlined herein. These files shall have no loss of drawing entities or project data that can result from standard CAD file translation procedures.
- 1.4.15.2 All ".DWG" files and CAD drawing entities submitted at the end of a project should be capable of manipulation through standard AutoCAD™ drafting procedures.

### (1.5) PROJECT COMPLETION

#### 1.5.1 As-Built” Record Drawings

- 1.5.1.1 The A/E shall submit final “as-built” documents to JMU in digital format, in addition to hardcopy format in accordance with the contract.
- 1.5.1.2 Two (2) full sized hard copies as well as three (3) flash drives containing digital copies of the record drawings are to be provided to the owner upon completion of the project.
- 1.5.1.3 The digital submittal shall contain the “as-built” information and .DWG, and .PDF formats of the CAD drawings in accordance with the CAD standards outlined herein.
- 1.5.1.4 All record drawings, including civil and site drawings, are required to have a signed and dated professional seal.
- 1.5.1.5 Record drawings shall include, as a minimum, all of the following:
  - 1.5.1.5.1 Physical Improvements
  - 1.5.1.5.2 Finished Floor Elevations
  - 1.5.1.5.3 JMU-approved final room numbering
  - 1.5.1.5.4 Physical evidence of underground utilities (valves, c/o, hydrants, vents, indicator posts, etc.)
  - 1.5.1.5.5 Sanitary and storm manhole inverts, pipe sizes, pipe material
  - 1.5.1.5.6 Boundary information (if shown on construction plans)
  - 1.5.1.5.7 Surveyors shall be licensed in the Commonwealth of Virginia.
  - 1.5.1.5.8 As-built drawings shall be provided upon completion of project in a 2-D CAD file, PDF format and a BIM model.
- 1.5.1.6 The digital PDF record sets shall include a drawing index with links enabling navigation to each drawing and detail.
- 1.5.1.7 Digital PDF copies of the contractors scanned “field set” will be considered unacceptable and should only be referenced in the making of an electronic set for record.
- 1.5.1.8 Every project shall depict all construction features, including all changes made during the construction process and all concealed utilities accurately located, as required by the State of Virginia Standard General Conditions.
- 1.5.1.9 Record drawing documentation requirements associated with Erosion and Sediment Control & Stormwater are covered under section 1.6.

#### 1.5.2 Operation and Maintenance Manuals

- 1.5.2.1 Operation and maintenance manuals are to be provided to the owner upon completion of the project and shall include all manufacturer’s information pertaining to the operation and maintenance of each type of system and component used in the building.
- 1.5.2.2 Operation and maintenance manuals are to be provided to the owner in both hard copy and electronic PDF format
  - 1.5.2.2.1 Provide two (2) copies bound in heavy-duty, three-ring, vinyl-covered, loose-leaf binders, large enough to accommodate contents, and sized to receive 8-1/2 x 11-inch (215mmx280mm) paper.



## DIVISION 01 – GENERAL REQUIREMENTS

- 1.5.5.2.1** Provide two (2) copies bound in heavy-duty, three-ring, vinyl-covered, loose-leaf binders, large enough to accommodate contents, and sized to receive 8-1/2 x 11-inch (215mmx280mm) paper.
- 1.5.5.2.2** Provide heavy paper dividers with plastic-covered tabs for each separate warranty.
- 1.5.5.2.3** Identify each warranty binder on the front and spine with the typed or printed title “WARRANTIES,” project name and name of Contractor.
- 1.5.5.2.4** Provide three (3) flash drives containing electronic copies of a single indexed PDF file with links enabling navigation to each warranty. Provide a bookmarked table of contents at the beginning of each document.

### (1.6) EROSION AND SEDIMENT CONTROL / STORMWATER

#### 1.6.1 General

- 1.6.1.1** JMU operates a Virginia Erosion and Stormwater Management Program (VESMP) through Annual Standards and Specifications as approved by the Virginia Department of Environmental Quality (DEQ). This document provides general guidelines for erosion and sediment control (ESC) and stormwater management (SWM) plan preparation and is regularly updated to reflect amendments to ESC and SWM law. For the latest version, please visit our website at [www.jmu.edu/stormwater](http://www.jmu.edu/stormwater) or contact the JMU Stormwater Coordinator.
- 1.6.1.2** All projects shall comply with JMU's Annual Standards and Specifications for ESC & SWM, the Virginia Erosion and Sediment Control Law, the Virginia Stormwater Management Act, associated ESC and SWM regulations and the Virginia Stormwater Program Permit regulations. An ESC control plan, narrative and supporting documentation shall be prepared and submitted to Facilities Engineering for review for any project which disturbs 10,000 square feet or more, or is considered part of a larger common plan of development. A stormwater management plan, narrative and supporting documentation shall be prepared and submitted to Facilities Engineering for review for any project which disturbs one (1) acre or more, or is considered part of a larger common plan of development.
- 1.6.1.3** Projects that do not meet the criteria for operating under an approved ESC site plan are still required to implement control measures, as needed, to prevent sediment deposition and other illicit discharges to adjacent properties, JMU's Municipal Separate Storm Sewer System (MS4) and waterways. These measures may include, but are not limited to construction entrances, road sweeping, silt fence installation, inlet protection, trash management and concrete washout facility locations. If additional guidance is needed, contact FM Engineering.
- 1.6.1.4** Additional stormwater related policy and procedure information concerning Daily Operational Procedures, Illicit Discharge Detection and Elimination (IDDE), Land Disturbing Activities and Stormwater Management Facilities can also be found on JMU's stormwater web pages.

#### 1.6.2 Plan Submittals & Review

- 1.6.2.1** Plan submittals for review shall be provided as described in JMU's Annual Standards and Specifications for ESC & SWM. A plan submittal checklist is included in the appendix of that document.
- 1.6.2.2** Comments from plan submittals are typically provided back to the project manager and design engineer within 30 days, but time frames may fluctuate depending on workload.

#### 1.6.3 Construction Prerequisites

- 1.6.3.1** Prior to proceeding with construction on projects requiring plan review, the following prerequisites shall be fulfilled:
- 1.6.3.1.1** Approval of ESC plans.
  - 1.6.3.1.2** Approval of SWM plans, if applicable.

## DIVISION 01 – GENERAL REQUIREMENTS

- 1.6.3.1.3** Notification of the projects Responsible Land Disturber (RLD). This information is to be provided as soon as known, as JMU is required to notify DEQ of this person and their contact information two weeks prior to the start of land disturbance. It is recommended that the RLD assigned to the project is part of the general contractor’s project team and will be on-site on a daily basis.
- 1.6.3.1.4** A pre-construction conference to clarify ESC/SWM roles, responsibilities and obligations of parties involved with the land disturbing activity shall be required. The JMU Project Manager, JMU Project Engineer, JMU Stormwater Coordinator, general contractor, project RLD, and if applicable, the general construction permit operator should be in attendance. Unless determined to not be needed, the design engineer should also be included in the pre-construction meeting. Contact the JMU Project Manager to coordinate this meeting.
- 1.6.3.1.5** Notification of off-site soil borrow and/or spoils locations in support of the project. For off-site locations, the contractor shall provide either a copy of an active/approved locality land-disturbing permit, a copy of an active DEQ permit coverage letter, or have the site plan amended to include the borrow/spoils area.
- 1.6.3.1.6** If the project requires state construction general permit coverage, a copy of the permit coverage letter will need to be forwarded to the JMU Stormwater Coordinator. It is recommended that the general contractor be the permit operator or someone that will have authority over contractors on-site and will be on-site on a daily basis. Please note that by submitting the registration statement for general permit coverage, the operator is certifying that they have received ESC and SWM plan approval, and a SWPPP has been prepared. A SWPPP template is available on JMU’s stormwater web pages. DEQ issues the construction general permit and information for registration statements and other needed information can be found on their web site.

### **1.6.4 Stormwater Pollution Prevention Plans (SWPPP)**

- 1.6.4.1** Projects requiring a DEQ general construction permit will also require a SWPPP. The SWPPP shall be prepared in accordance with the requirements of the General Permit for Discharges of Stormwater from Construction Activities before submitting the registration statement. An initial SWPPP will be developed by the JMU Stormwater Team and provided to the JMU Project Manager for completion by the contractor or project team. The SWPPP, SWPPP updates, and all components within will be the responsibility of the contractor.
- 1.6.4.2** The initial SWPPP certification statement shall be signed by the same individual that signed the Registration Statement for permit coverage (contractor certification form). Any other person named to be responsible for the site, whether entirely or parts within, shall have that duty delegated to that individual or position (delegation of authority form). All sub-contractors that bring “potential pollutants” on-site that may be expected to be exposed to stormwater shall provide information on those activities

## DIVISION 01 – GENERAL REQUIREMENTS

(subcontractor certification form). This will include, but is not limited to, excavator, concrete, landscape, masonry, painting, and fueling contractors.

- 1.6.4.3 Streams within the JMU watershed are designated as impaired waters. As such, additional construction permit requirements will need to be implemented as part of project compliance. See DEQ's current permit language for specifics.

### 1.6.5 Construction

- 1.6.5.1 ESC minimum standards shall be implemented on-site (9VAC25-840-40).
- 1.6.5.2 During construction, between the responsibilities of the RLD, permit operator and any other contractor's delegated responsibilities related to ESC and SWM, the site shall be evaluated daily and corrective actions and/or measures taken immediately to resolve possible non-compliance issues.
- 1.6.5.3 JMU will perform periodic inspections as required by the DEQ approved annual standards and specification to confirm compliance with the VESCP, VSMP, MS4 Program, and IDDE Program. Measures installed shall be expected to meet the standards and specifications as shown in the approved site plan, DEQ's ESC Handbook, DEQ's Approved Stormwater BMP Standards and Specifications (BMP Clearinghouse) or JMU's Annual Standards and Specifications for ESC and SWM. It shall be the responsibility of the contractor designated as the construction general permit operator and/or the RLD for the project to ensure non-compliance issues noted on reports are addressed in a timely manner.
- 1.6.5.4 It shall be the responsibility of the construction general permit operator to have a complete and updated SWPPP on-site for review, if applicable to the project.
- 1.6.5.5 Any amendments to the approved plan that may affect ESC or SWM shall be submitted to the JMU Stormwater Coordinator for review prior to implementing measures on-site. This shall also include any support activities outside the projects limits of disturbance.
- 1.6.5.6 The contractor shall notify the stormwater compliance inspector at least 48 hours prior to starting installation of permanent stormwater BMPs.

### 1.6.6 Project Completion

- 1.6.6.1 Prior to closing out a project for ESC or SWM, several items will need completed before the permit Notice of Termination can be submitted to DEQ.
- 1.6.6.2 Any land disturbance made in support of the project, whether within or outside the project limits, will be expected to be adequately stabilized. In compliance with ESC minimum standard 3, a permanent vegetative cover shall be established on denuded areas not otherwise permanently stabilized. Permanent vegetation shall not be considered established until a ground cover is achieved that is uniform, mature enough to survive and will inhibit erosion (9VAC25-840-40 3).
- 1.6.6.3 In compliance with minimum standard 18, all temporary erosion and sediment control measures are removed and any trapped sediment and disturbed soil areas resulting from the disposition of temporary measures shall be permanently stabilized (9VAC25-840-40 18).
- 1.6.6.4 An estimated cost for construction/installation of each stormwater BMP will be needed.

## DIVISION 01 – GENERAL REQUIREMENTS

- 1.6.6.5** For projects working under a construction general permit, a construction record drawing for permanent stormwater management facilities shall be submitted to the JMU Stormwater Coordinator. The project team shall work closely with their engineer to ensure the engineer is on-site as needed to certify installation measures are performed per plan and meets specifications. The construction record drawing shall be appropriately sealed and signed by a professional registered in the Commonwealth of Virginia, certifying that the stormwater management facilities have been constructed in accordance with the approved plan (9VAC25-870-55 D). The DEQ has provided the following template for the certification statement:

<b><u>STORMWATER MANAGEMENT FACILITIES CERTIFICATION</u></b>	
Pursuant to 9VAC25-870-55, I hereby certify that to the best of my knowledge and belief the stormwater management facilities shown on these record drawings have been constructed in accordance with the approved plans and specifications.	
_____	_____
Name	Signature
_____	_____
Virginia License	Date
"Certify" means to state or declare a professional opinion based on sufficient and appropriate onsite inspections, material tests, as-built survey data, and information provided by other professionals and the contractor, conducted during or after construction.	

- 1.6.6.6** Note that final close out of projects under a VSMP permit are contingent on (1) BMP as-built certification from an engineer, and (2) a final inspection and letter of permit termination from DEQ.

### 1.6.7 Construction Record Drawing Documentation

- 1.6.7.1** In addition to the record drawing, ensure the following information is provided for the following BMP's as needed:

**1.6.7.2** Bio-Retention

**1.6.7.2.1** Topographical survey of basin bottom before fill material is placed. (verifying depth provides space for fill materials)

**1.6.7.2.2** Testing and verification of waterproof membranes. (density report for clay liner, specifications and thickness of liner used, etc.

**1.6.7.2.3** Soil media delivery tickets.

**1.6.7.2.4** Photo documentation of installation of the following.

- ⇒ Fabric liner
- ⇒ Stone layer with underdrain
- ⇒ Pea gravel

## DIVISION 01 – GENERAL REQUIREMENTS

- ⇒ Soil media (ensure an additional 10% is provided per the standards and specifications to allow for settling)
- ⇒ Mulch
- ⇒ Height of outlet structure
- ⇒ Freeboard measurements
- 1.6.7.2.5** Topographical survey after complete with storage volume calculated.
- 1.6.7.3** Detention Basin
  - 1.6.7.3.1** Topographical survey after complete with storage volume calculated.
  - 1.6.7.3.2** Testing and verification of waterproof membranes. (density report for clay liner, specifications and thickness of liner used, etc.)
  - 1.6.7.3.3** Finish grade elevations
    - ⇒ Pipe inlets and outlets
    - ⇒ Control structure rim, inlet and outlet
    - ⇒ Top of bank
    - ⇒ Basin bottom
    - ⇒ Emergency spillway
- 1.6.7.4** Detention Basin, Underground
  - 1.6.7.4.1** Finish grade elevations
    - ⇒ Rim
    - ⇒ Pipe inlets and outlets
    - ⇒ Floor
    - ⇒ Any control structure elevations
- 1.6.7.5** Forest, Open Space, & Meadows
  - 1.6.7.5.1** Survey exhibit showing as-built boundary of area with metes and bounds.
  - 1.6.7.5.2** Photo documentation of installation/construction
    - ⇒ Site grading/prep
    - ⇒ Top soil, and other soil amendments
    - ⇒ Verification of seed mix used
    - ⇒ Verification of plantings used
    - ⇒ Final stabilization
- 1.6.7.6** Hydrodynamic Separator
  - 1.6.7.6.1** Photo documentation of installation
  - 1.6.7.6.2** Finish grade elevations
    - ⇒ Rim
    - ⇒ Pipe inlets and outlets
    - ⇒ Sump
- 1.6.7.7** Permeable Pavements
  - 1.6.7.7.1** Photo documentation of installation
    - ⇒ Depth before fill material is placed.
    - ⇒ Fabric liner
    - ⇒ Stone layer with underdrain
    - ⇒ Other stone layers
    - ⇒ Geogrid

## DIVISION 01 – GENERAL REQUIREMENTS

⇒ Pavers

**1.6.7.7.2** Invert elevations of all piping to show positive flow to outlet.

### **1.6.7.8** Stormfilter Systems

**1.6.7.8.1** Photo documentation of installation

**1.6.7.8.2** Activation/Certification letter from installer.

**1.6.7.8.3** Finish grade elevation for rim, pipe inlets and outlets and sump.

**1.6.7.8.4** Number of filters and filter type.

### **1.6.7.9** Tree in a Box Manufactured Systems (Filterra, etc.)

**1.6.7.9.1** Photo documentation of installation

**1.6.7.9.2** Activation/Certification letter from installer.

**1.6.7.9.3** Finish grade elevations for system drop inlet and bypass/overflow inlet.

**1.6.7.9.4** Type of plant installed in system.

**1.6.7.10** If stormwater BMP's were not constructed in accordance with the approved plan, construction repairs will need to be made or an engineer will need to submit a plan amendment showing that the final product is in compliance with regulations for approvals.

**1.6.7.11** Please note that stormwater BMP's should not be constructed until the contributing drainage area is stabilized. If this practice is not followed, any sedimentation accumulated in the BMP will need to be removed or the BMP repaired or replaced at the contractors expense.

### **1.6.8** Construction General Permit (CGP) Notice of Termination (NOT)

**1.6.8.1** The CGP is issued by the DEQ and they will perform an inspection before approving a NOT. DEQ typically performs their final inspection within 60 days of receiving the NOT. As such, the permit coverage letter from DEQ shall continue to be posted until an acceptance letter of the NOT is received from DEQ or 60 days after the submittal of the NOT from the construction operator.

**1.6.8.2** Please note that the NOT shall not be submitted to the DEQ until all ESC and SWM items have been closed out. An inspection report from JMU will be provided stating that ESC and SWM has been completed.

**1.6.8.3** Provide JMU's Stormwater Coordinator with a copy of the NOT along with the date submitted to the DEQ.

**1.6.8.4** As-built documentation along with the approved plans will need to be provided to DEQ. For additional information on the Construction General Permit and the Notice of Termination process, please contact DEQ.

### (1.7) Mock-Up Requirements

#### 1.7.1 General

- 1.7.1.1 The mock-up is intended for review of materials, components and to set the standards of workmanship for all portions of assemblies demonstrated.
- 1.7.1.2 The mock-up shall be free standing and may not be incorporated into the final work.
- 1.7.1.3 The A/E shall provide a plan and all details for the required mock-ups as part of the Construction Drawings.

#### 1.7.2 Mock-Up Construction

- 1.7.2.1 The construction manager or general contractor will include a construction schedule for the mock-up construction and approvals as part of the overall project construction scheduled to be reviewed and approved by JMU.
- 1.7.2.2 Materials and finishes shall comply with the requirements per the A/E specifications.
- 1.7.2.3 The mock-up shall incorporate all related construction materials and finishes having a visual effect on the completed work.
- 1.7.2.4 Protection of the mock-up is the construction manager or general contractor's responsibility.

#### 1.7.3 Mock-Up Approval

- 1.7.3.1 Sequencing of mock-up approval:
  - 1.7.3.1.1 Architect to review and approve.
  - 1.7.3.1.2 JMU Office of Facilities Planning and Construction to review and approve.
  - 1.7.3.1.3 JMU Associate Vice President of Business Services to review and approve.
  - 1.7.3.1.4 JMU Senior Vice President of Administration and Finance has the final approval over the mock-up.
- 1.7.3.2 No work may start that include the materials and finishes included in the mock-up until all the approvals are complete.

**(3.1) FOOTINGS & FOUNDATIONS**

**3.1.1 Footings**

- 3.1.1.1** Over-excavated footings shall only be backfilled with #57 stone and shall be approved by the Engineer of Record *prior* to placement.
- 3.1.1.2** Clean cut earth forms are acceptable for non-exposed concrete footings.
- 3.1.1.3** Under-slab vapor barrier shall be continuous, extending under and around all sides of the building footing and incorporated into the exterior foundation water-proofing system.
- 3.1.1.4** The horizontal ledge, or top of all footings, shall be parged away from the foundation and incorporated into the below-grade damp or water-proofing foundation design.

**3.1.2 Foundations**

- 3.1.2.1** All foundations shall have exterior drain tile that drains to daylight or to an approved stormwater system.
- 3.1.2.2** Drain tile shall be located adjacent to the bottom of the footing.
- 3.1.2.3** Drain tile shall be protected against infiltration of stone or fine granular material using a “sock” or other approved encasing material.
- 3.1.2.4** All foundations shall be backfilled with a 24” minimum width of #57 stone against the foundation, wrapped in landscaping fabric on all sides exposed to earth backfill.
- 3.1.2.5** All foundations, whether containing below-grade occupiable space or not, shall be fully waterproofed with both direct-applied coatings and dimpled-membrane coverings.
- 3.1.2.6** Minimum thickness of all sub-slab and foundation vapor barriers shall be 15mils and fiber reinforced.

## (3.2) CONCRETE

### 3.2.1 General

3.2.1.1 The following American Concrete Institute (ACI) are included as a reference:

- *ACI 301* – “Specification for Structural Concrete”
- *ACI 318* – “Building Code Requirements for Structural Concrete,” and all referenced standards therein
- *ACI 305* – “Guide to Hot-Weather Concreting”
- *ACI 306* – “Guide to Cold-Weather Concreting”
- *ACI 347* – “Guide to Formwork for Concrete”

3.2.1.2 All construction drawings proposing new structural concrete placement shall include the Statement of Special Inspections in accordance with VCC table 1704.4.

3.2.1.3 All concrete, grout and mortar washouts shall be done off-campus or into previously approved washout bins.

### 3.2.2 Concrete Mixes

3.2.2.1 All concrete shall have a minimum 28-day compressive strength of 4000psi.

3.2.2.2 All exposed exterior concrete shall be classified as “Exposure Class F3” in accordance with ACI 318 (table 4.4.1). Air entrainment for exposed exterior concrete shall be provided at this classification.

3.2.2.3 The use of admixtures is not recommended.

### 3.2.3 Formwork

3.2.3.1 Exposed concrete forms shall be inspected by the JMU PM or project inspector prior to use or re-use.

3.2.3.2 Release agents shall meet all current EPA requirements. Only non-staining, water-based agents shall be used.

### 3.2.4 Slump

3.2.4.1 Shall be determined by code based on application.

3.2.4.2 Shall be verified by special inspection.

### 3.2.5 Placement

3.2.5.1 All concrete placement shall be in accordance with ACI 318, and the referenced provisions therein.

### 3.2.6 Interior Slabs

3.2.6.1 All interior slabs at grade with a floor below with a possible exposed expansion joint at the perimeter shall be poured with a turn-down edge over the foundation wall. Turn down to be deep enough that joint to foundation wall can be covered by waterproofing.

3.2.6.2 All slabs shall incorporate an approved expansion joint at all slab edges.

3.2.6.3 All interior slabs shall include a vapor barrier. The exceptions of VCC 1910 are limited to applying only to areas such as driveways, sidewalks, etc.

3.2.6.4 All slabs shall have a 6” minimum base layer of #21A stone base below the vapor barrier.

3.2.6.5 All slabs on grade shall have a control joint pattern no larger than 10’x10’. Pattern to be reviewed and approved by JMU.

3.2.6.6 Under-slab vapor barrier shall be a minimum thickness of 15-mils.

- 3.2.6.7 Vapor barrier joints and all other penetrations shall be overlapped a minimum of 6" and shall be taped with an approved vapor-barrier tape per manufacturer's specifications.
- 3.2.6.8 Exposed *interior* concrete slabs shall be sealed in accordance with the building design, but shall always be designed to be highly resistant to de-icing salt exposure. Acrylic sealants are not allowed.

### 3.2.7 Sidewalks and Exterior Slabs

- 3.2.7.1 All concrete shall be designed in accordance with accepted engineering practices in regards to potential vehicular loading. Pedestrian-only sidewalks shall have a 6" minimum base of #57 or #21 stone beneath the concrete.
- 3.2.7.2 Sidewalks shall be a minimum of 8' in width.
- 3.2.7.3 Sidewalks shall be a minimum of 6" in thickness, except as noted for fire apparatus access or other engineered loading scenarios.
- 3.2.7.4 Provide ½" expansion joints at a maximum distance of 20'. Plastic-capped expansion joints shall remove the plastic and caulk the tops.
- 3.2.7.5 They shall also be scored at 5' intervals.
- 3.2.7.6 All sidewalks shall be reinforced with 6x6 W1.4/W1.4 welded wire fabric (WWF) or fiber-reinforced concrete. Overlap in the WWF shall be a minimum of 6" and shall not occur within 12" of the score.
- 3.2.7.7 Sidewalks shall not include a vapor barrier.
- 3.2.7.8 Exposed *exterior* slabs and sidewalks shall be treated with a penetrating sealer (silanes, siloxanes and silicates), in accordance with the manufacturer's specifications. Sealants shall be shown to be compatible with the air-entrainment percentage of the concrete, and shall specify curing time before application.

**(4.1) MASONRY**

**4.1.1 General**

- 4.1.1.1 All Bluestone specs shall be contained in the Bluestone section. This section applies to all other structural and veneer masonry walls.
- 4.1.1.2 The top courses of all open masonry shall be durably protected from foreign object entry at the end of every day.
- 4.1.1.3 Partially completed walls shall not be toothed, but shall be racked back at the end of each day.
- 4.1.1.4 All work shall be plumb, level and true to line. Story poles laid out with courses shall be used on all masonry construction.
- 4.1.1.5 At the start of each work day the exposed tops of all units shall be cleaned and free of all dust and debris and dampened before resuming work.
- 4.1.1.6 All masonry shall be dampened before application to prevent the rapid curing of mortar.
- 4.1.1.7 When cut masonry units are necessary, only clean, square cuts shall be allowed and all adjacent head and bed joints shall be of uniform thickness.
- 4.1.1.8 Minimum thickness of all structural CMU walls is 8”.
- 4.1.1.9 FHA block or other semi-solid block shall not be used in lieu of required solid masonry.
- 4.1.1.10 See section [13.1.3](#)
- 4.1.1.11 Required mockups shall be provided and approved before any installation begins. See mock-up requirements in Division 1 Section 6.

**4.1.2 Sills**

- 4.1.2.1 All masonry veneer buildings shall use pre-cast, non-porous sills for all punched openings.
- 4.1.2.2 Sills shall be one-piece when the opening is <8’ in width. Where multiple piece sills are used, the vertical joints shall be located in line with window openings, flashing joints or other wall elements above that create the potential for increased areas of wetting.
- 4.1.2.3 Sills shall extend a minimum of 4” in each direction beyond the width of the opening.

**4.1.3 Mortar**

- 4.1.3.1 Masonry mortar shall not be mixed unless the outdoor air temperature is above 40° F and rising without the specific approval of the project manager. Any cold-weather mortar mixing and applications shall comply with the most restrictive provisions of the current MSJC code.
- 4.1.3.2 All masonry shall have full bed and head joints.
- 4.1.3.3 Mortar shall not be re-tempered.
- 4.1.3.4 All joints shall be uniformly struck and the backsides shall not be parged. Exposed joints shall be struck in timely manner to produce an even coloration throughout the entire wall.
- 4.1.3.5 All mortar shall be consistent in color throughout and color match the mockup. Discolored mortar will be replaced prior to Final Completion
- 4.1.3.6 All mortar joints shall be concave or weathered to minimize water intrusion.

- 4.1.3.7 Cavity protection shall be provided throughout the entire installation to minimize backside mortar droppings.
- 4.1.3.8 Projecting courses shall not be set until mortar is set enough to prevent extrusion. All projecting courses shall be durably supported until mortar has cured.

### 4.1.4 Flashing

- 4.1.4.1 Flashing courses and weeps shall be inspected by the JMU PM or inspector before covering.
- 4.1.4.2 Weep holes or screeds shall not be damaged by masonry installation and shall aesthetically complement the surrounding area.
- 4.1.4.3 Every course of flashing and weeps shall be protected by a minimum of a 10" approved mortar net.
- 4.1.4.4 Weeps shall be placed at a minimum of 24" apart and shall extend into the cavity to at least the full cavity depth.
- 4.1.4.5 Weeps shall be designed to allow air circulation through the entire cavity.
- 4.1.4.6 Flashings shall be regletted into the backing masonry joints and sealed with an elastomeric sealant.

### 4.1.5 Grout

- 4.1.5.1 All metal doorframes in masonry walls shall be solid grouted.
- 4.1.5.2 Grout mixtures shall be constantly monitored by an on-site 3<sup>rd</sup> party inspector.

### 4.1.6 Accessories

- 4.1.6.1 All masonry ties and other structural elements shall be grade 304 stainless steel.

**(4.2) BLUESTONE****4.2.1 General**

**4.2.1.1** This section addresses the installation of new Bluestone veneer on exterior and interior walls of new building construction and may also be used as a general guideline for the repair of existing Bluestone veneer. It is *not* intended to cover work associated with solid Bluestone wall construction, as is typically found on many of the Bluestone Campus Buildings constructed prior to 1950.

**4.2.1.2** See section 2.1.3 regarding washout requirements.

**4.2.2 Bluestone Sources**

**4.2.2.1** Bluestone shall be furnished from a single quarry source as specified in the construction drawings and shall be pre-approved by JMU.

**4.2.2.2** Bluestone sources previously used on projects at JMU include the following:

- Lilac Quarries, Gilbertsville, NY - Preferred

**4.2.2.3** Bluestone from other sources may be used only if approved in writing by JMU. Stone samples shall be furnished as a part of the review and approval process.

**4.2.3 Veneer Anchors and Embedded Accessories**

**4.2.3.1** *All stone ties and anchors shall be stainless steel.* Galvanized steel ties are not acceptable for any stone masonry work at JMU.

**4.2.3.2** Prefabricated veneer anchor ties designed specifically for stone masonry shall be used as the standard method for securing Bluestone veneer to structural backup materials.

**4.2.3.3** Cast-in-place concrete backer walls shall use an embedded stainless steel channel slot cast into the concrete wall face in conjunction with stainless steel slot ties.

**4.2.3.4** Individual screw-attached wall ties may be used for attachment of Bluestone to masonry backup walls.

**4.2.3.5** Install stone anchors at spacing not to exceed 16" vertically and 24" horizontally.

**4.2.3.6** Ensure that anchors are placed such that they extend a minimum of 1.5" inches into the bed joint of the stone.

**4.2.3.7** Provide additional anchorage for stones greater than 2ft<sup>2</sup> and at all punched openings.

**4.2.4 Mortar and Grout**

**4.2.4.1** Mortar mix for setting stone shall be:

- 1 part Portland cement
- ½ part hydrated Lime
- 4.5 parts sand

**4.2.4.2** Mortar mix for pointing shall be:

- 1 part Portland cement
- 1 part hydrated lime
- 3 parts sand

**4.2.4.3** Color pigment additive may be used as approved by JMU.

**4.2.4.4** Other mortar additives such as calcium chloride, anti-freeze admixtures, air entraining admixtures or other admixtures which promote corrosion of ferrous metals are strictly prohibited.

- 4.2.4.5 Grout for infill of cavity space behind stone in short wall or concrete wall construction at or near grade/foundation levels shall be Portland cement/sand grout meeting proportion requirements of ASTM C 476 for “fine grout.”
- 4.2.4.6 Grout shall have a minimum 28-day compressive strength of 2,000psi. Slump shall be suitable for the width and depth of cavity space to be filled and shall be monitored by on-site third-party inspections. Consolidate grout by rodding or vibrating to ensure that the cavity space is completely filled.
- 4.2.5 Site Delivery and Storage**
  - 4.2.5.1 Stone shall be stored in a secure location, off the ground, and covered to prevent soiling or other damage to bedding surfaces.
  - 4.2.5.2 Other stone masonry materials, including cementitious mortar mix materials, shall be stored in a covered, dry location. The use of cementitious materials that have become damp during storage is not permitted.
  - 4.2.5.3 Store other accessories such as ties and anchors, in a secure location where they will not become contaminated with foreign materials such as oil and dirt.
- 4.2.6 Field Dressing/Facing and Cutting of Bluestone**
  - 4.2.6.1 The construction drawings shall specify an acceptable range and percentage of stone sizes to be used in a given location.
  - 4.2.6.2 The stone masonry contractor is responsible for the field-facing of the quarried stone to the required fit and finish specified in the approved construction drawings.
  - 4.2.6.3 The final minimum head and bed thickness of all stone to be used in elevated veneer wall construction shall be no less than 4” after dressing.
  - 4.2.6.4 Store field-dressed stone as specified in 1.5.2 above.
  - 4.2.6.5 The stone masonry contractor is responsible for cutting the stone to final size as necessary to fit specific wall locations and desired stonework pattern.
  - 4.2.6.6 Stones that are less than 4” thick, have cracks, soft seams, mud veins, high iron content or contain other visibly defective conditions shall not be used in any locations.
- 4.2.7 Installation**
  - 4.2.7.1 All backing surfaces to which Bluestone veneer is to be applied shall be verified by the designated **JMU** inspector to be in compliance with all requirements before any mounting or securing of stone work.
  - 4.2.7.2 The engineer of record shall verify that the embedded anchorage systems in backer walls have been installed at the spacing and locations shown on the approved construction drawings. Bluestone veneer shall not be installed over surfaces that do not comply with all requirements.
  - 4.2.7.3 The **JMU** inspector shall verify the installation of all related materials such as flashings, cavity insulation, drainage mats and other similar items throughout the construction process.
  - 4.2.7.4 Required mockups shall be provided and approved before any installation begins.
  - 4.2.7.5 Keep cavity space free of excess mortar droppings. Remove excess mortar as stone is being laid to avoid bridging between back of stone and insulation board.
  - 4.2.7.6 Provide openings, chases, recesses and other similar features as required for the installation of other trade work.

- 4.2.7.7 Both vertical expansion/movement joints and horizontal relief joints shall be used. Do not allow mortar to bridge across these joints.
- 4.2.7.8 Comply with Cold-Weather construction requirements contained in ACI 530.1/ASCE 6/TMS 602. Do not build on frozen substrates or use materials that are coated with frost or ice.
- 4.2.7.9 Comply with Hot-Weather construction requirements contained in ACI 530.1/ASCE 6/TMS 602. Protect masonry from accelerated drying due to direct exposure to sunlight or wind.
- 4.2.8 Protection of Masonry Work During Installation and Cleaning**
  - 4.2.8.1 Cover partially completed stone masonry work when construction is not in progress.
  - 4.2.8.2 Cover tops of walls, sills and other projections with waterproof sheeting at the end of each day's work until masonry work has been completed.
  - 4.2.8.3 Cover material shall be secured and extend at least 24" below the finished work.
  - 4.2.8.4 Protect built-in items from mortar droppings during construction.
  - 4.2.8.5 Clean stone masonry as the work progresses and at the end of each day.
  - 4.2.8.6 Final cleaning of completed work after mortar has set and thoroughly cured may require the use of proprietary cleaners. Use only cleaners that are specifically designed for use on Bluestone masonry and pre-approved by JMU.
  - 4.2.8.7 High pressure washing or cleaning of any Bluestone masonry is prohibited at JMU.

**(5.1) STEEL**

**5.1.1 General**

- 5.1.1.1 Exposed steel shall be hot-dipped galvanized to ASTM 153 standards or stainless steel.
- 5.1.1.2 Structural steel, bolts or other structural steel members shall not bear on any non-structural masonry veneer.

**5.1.2 Welding/Tensioning**

- 5.1.2.1 The engineer of record shall submit the Statement of Special Inspections with the construction drawings to provide the inspection schedule for welding of all structural joints and bolt tensioning.
- 5.1.2.2 At the completion of structural work, the engineer shall submit the signed and completed Statement verifying the proper installation of all structural steel members.
- 5.1.2.3 The welding of galvanized steel shall require a new galvanic paint coating.

**5.1.3 Handrails/Guardrails**

- 5.1.3.1 All exterior campus handrails shall be anodized aluminum or stainless steel. Substitutions acceptable with JMU approval prior to the completion of the Preliminary Design phase.
- 5.1.3.2 All interior campus handrails are preferred to be aluminum, stainless steel or painted steel. Substitutions acceptable with JMU approval prior to the completion of the Preliminary Drawings phase.
- 5.1.3.3 Exterior handrails in the Bluestone area are to be bronze and match the style and finish of the handrails at Wilson Hall.
- 5.1.3.4 All campus handrails shall be continuous and graspable for their entire lengths.
- 5.1.3.5 All handrails shall be ground smooth and free of any burrs or other defects.
- 5.1.3.6 All handrail vertical standards shall be stainless steel to at least 4 inches above mounting surface or ground contact.
- 5.1.3.7 Fully grout base of handrails of core drilled into concrete. The base of the handrail shall have positive drainage away from the handrail.

**5.1.4 Stairs/Ladders**

- 5.1.4.1 Exterior stair nosing shall be anodized aluminum or stainless steel with anti-skid devices, and use stainless steel anchors.
- 5.1.4.2 Exterior ladders of any sort shall be engineered for their intended use.

## DIVISION 06 – WOOD, PLASTICS, AND COMPOSITES

### (6.1) WOOD & PLASTIC

- 6.1.1 Preservative treated (PT) lumber shall not be used in finished walls.
- 6.1.2 Stainless steel fasteners and hardware shall be provided in conjunction with PT and/or fire-retardant (FR) woodwork.
- 6.1.3 All finish carpentry shall match adjacent surfaces in existing building or a defined transition shall be installed.
- 6.1.4 Modular sizes shall be used throughout campus.
- 6.1.5 Exposed finished cabinetry surfaces shall be HD premium plastic laminate or hardwood veneers.
- 6.1.6 Use concealed-face frame Euro-style hinges on all cabinetry.
- 6.1.7 All cabinetry shall use Euro-spaced modular shelf pin systems. Spare shelf pins shall be provided upon job completion.
- 6.1.8 All cabinet doors and drawers to have 4" wire pulls minimum. Style and finish to reviewed and approved by JMU prior to the completion of the Preliminary Design phase.
- 6.1.9 All casework to be AWI premium grade. Particle board shall not be used in any applications.
- 6.1.10 Countertops to be constructed of (2) layers ¾" plywood minimum.

## DIVISION 07 – THERMAL AND MOISTURE PROTECTION

### (7.1) THERMAL & MOISTURE

#### 7.1.1 Moisture

- 7.1.1.1 Foundation and slab moisture guidelines are in the Footings & Foundations section.
- 7.1.1.2 All components and materials subject to exterior conditions shall contain an approved moisture barrier.
- 7.1.1.3 The backing wall of all cavity wall systems shall incorporate a full moisture barrier into the drainage plane on their exterior side; e.g. closed-cell spray foam, rigid foam w/taped seams, etc.
- 7.1.1.4 All openings shall incorporate their flashing and drainage systems into the wall drainage plane.
- 7.1.1.5 The primary drainage plane shall be located on the outside of the continuous insulation layer.

#### 7.1.2 Vapor

- 7.1.2.1 Walls and roofs shall be designed to be primarily vapor permeable on their interior sides.
- 7.1.2.2 The use of Class I vapor barriers (<.1 perm) is not allowed on the interior side of any above-grade applications. Sheet plastic is not allowed in any wall or roof assemblies. The use of foil-faced polyisocyanurate insulation is acceptable on the exterior side of cavity wall systems and roofs.
- 7.1.2.3 Slab and foundations shall use Class I vapor barriers.
- 7.1.2.4 Vinyl wall coverings (wallpaper) shall not be used in any building.

#### 7.1.3 Thermal

- 7.1.3.1 Priority shall be given to the thermal envelope of all buildings, as it is highly cost-prohibitive to make future upgrades to these areas.
- 7.1.3.2 The insulation of all structural elements shall be designed to prevent their interior sides from reaching their respective dew points.
- 7.1.3.3 New buildings shall meet or exceed their total minimum insulation requirements through the use of continuous, exterior-side insulation.
- 7.1.3.4 The use of cavity insulation in steel stud walls is not allowed to meet thermal insulation requirements, not excluding any requirements for acoustics or fire ratings.
- 7.1.3.5 Renovation work shall meet the full insulation value with continuous insulation wherever practicable. Renovation work in existing single-wythe bluestone buildings shall use interior, direct-applied, closed-cell spray foam insulation wherever practicable.
- 7.1.3.6 Exterior insulation of walls shall be closed-cell spray foam or foil-faced polyiso.
- 7.1.3.7 All below-grade rooms (regardless of use and occupation category) shall be insulated fully and then extended either vertically or horizontally, to a minimum depth of 24" below the level of the lowest slab.
- 7.1.3.8 The thermal envelope shall be unbroken from the top of the footing, up the walls and around the roof to the maximum extent practicable.
- 7.1.3.9 Parapet walls shall be insulated on all sides and tops.
- 7.1.3.10 Low-slope roof hatches shall have a minimum insulation value of R-15.

## DIVISION 07 – THERMAL AND MOISTURE PROTECTION

### 7.1.4 Flashing

- 7.1.4.1 All flashings within a building shall be visually and chemically compatible with all other building materials in that building.
- 7.1.4.2 All flashings shall be incorporated into the primary drainage plane.
- 7.1.4.3 All flashings shall contain drip edges to remove and discharge bulk water a minimum of ½" beyond the furthest face of the wall below.
- 7.1.4.4 The top of all windows, doors and other such openings in the veneer shall have integral drip-edge flashing and be wept to the outside. The bottoms of all windows shall have integral flashing and be wept to the outside within the first 12" below the opening.
- 7.1.4.5 All horizontal projections shall be provided with protective flashing and be designed to shed and/or weep away from the building.
- 7.1.4.6 All flashing elements are subject to spot inspections.

## DIVISION 07 – THERMAL AND MOISTURE PROTECTION

### (7.5) ROOFING

#### 7.2.1 General

- 7.2.1.1 Roof access shall be provided from inside the building to accommodate inspections, repairs, and drain cleaning. Permanent ladders or stairs shall be provided as necessary to access each roof level.
- 7.2.1.2 Snow guards are required for all roofs with a slope of 6:12 or greater and over all entrances regardless of slope.
- 7.2.1.3 Roof covering choice shall consider the views from higher elevated structures.
- 7.2.1.4 Entries and doorways shall be protected from falling snow, ice, and water. Heat tape shall not be used.
- 7.2.1.5 All roofing shall have deck pads from roof access points to all serviceable rooftop mounted units. Construction drawings shall clearly show these traffic pad locations and dimensions. Enlarge roof pad area at roof access points for equipment staging.
- 7.2.1.6 Provide a frost-protected hose bib on each new building roof. Whenever possible provide a frost-protected hose bib on re-roofs if one does not currently exist.
- 7.2.1.7 All roofs shall have utility outlets located no more than 200' apart.
- 7.2.1.8 Skylights shall not be used.
- 7.2.1.9 Roof hatches shall be considered for replacement in all re-roofing projects. (see section 17)
- 7.2.1.10 Through-the-wall secondary drains shall be preferred to internal drain piping.

#### 7.2.2 Coverings

- 7.2.2.1 Clay tiles shall be Spanish tiles as manufactured by Ludowici Celadon or approved equal to match existing clay tile roofs.
- 7.2.2.2 Low-slope and flat roofing to be 60-mil, fully adhered, single ply EPDM by Carlisle or Firestone. TPO, PVC and other low-slope coverings will be considered based on usage.

#### 7.2.3 Metal

- 7.2.3.1 Metal for flashing and drip edge shall be copper, not less than sixteen ounces (16oz.). When flashing occurs extensively in connection with aluminum items, stainless steel (grade 304) or aluminum flashing not less than 0.032" thick shall be used. All flashing joints shall overlap 4" minimum and shall be sealed with a manufacturer approved elastomeric sealant.
- 7.2.3.2 Roofing system flashing and miscellaneous sheet metal work shall be installed in accordance with the manufacturer's published instructions and provide a guarantee to meet or exceed the life of the roof.
- 7.2.3.3 Provide concealed EPDM-gasketed fasteners in all flashing. Fastening shall only occur on the vertical portions of flashings.
- 7.2.3.4 Bluestone gutter downfalls shall be copper. All downfalls shall be provided with an accessible cast iron cleanout at ground level.
- 7.2.3.5 All roof drain covers shall be metal.

**(8.1) OPENINGS**

**8.1.1 General**

- 8.1.1.1 All doors shall be a minimum of 3’ in width.
- 8.1.1.2 Thresholds for trash rooms, bathrooms and custodial rooms shall be watertight.
- 8.1.1.3 All pre-finished windows shall have protective coverings during constructions. These protective coverings shall not be removed until the project is ready for the substantial completion inspection.
- 8.1.1.4 Replacement and new windows in the Bluestone area buildings shall match the original historic window style and shall be aluminum clad wood windows with insulated glass to meet current energy efficiency requirements. Fiberglass clad wood windows can be a substitution to be reviewed and approved by JMU prior to the completion of the Preliminary Design phase.
- 8.1.1.5 Window selection shall consider the window styles of surrounding buildings and visually adjacent windows.
- 8.1.1.6 Skylights shall not be used in any occupied spaces.
- 8.1.1.7 Plastics shall not be used in lieu of glass.
- 8.1.1.8 All required safety glazing shall be laminated glass.
- 8.1.1.9 Single glazed windows are allowed in interior windows only and shall be a minimum of ¼” thick glass.
- 8.1.1.10 Glazing tint color shall coordinate with existing campus aesthetic.
  - 8.1.1.10.1 Bluestone area – Solarban 60 Solarbronze is preferred.
  - 8.1.1.10.2 Remaining campus Solarban 60 Clear is preferred.
  - 8.1.1.10.3 Substitutions to be reviewed and approved by JMU prior to the completion of the Preliminary Design Phase.
- 8.1.1.11 Center mullions on double doors shall be removable and keyed with the doors.

**8.1.2 Hardware**

- 8.1.2.1 All door closers shall be heavy-duty cast iron with a minimum 10-year warranty. Closers shall be thru-bolted to doors at a minimum height of 80” A.F.F.
- 8.1.2.2 All door closers shall be provided with compatibility for automatic hold-open devices.
- 8.1.2.3 Provide a minimum of one automatic door opener at each bank of accessible egress doors. The open switch shall be hard-wired into the emergency circuit and be provided with battery backup. Add note on construction drawings “Open switch location shall be reviewed and approved by JMU prior to the start of installation.”
- 8.1.2.4 Do not use pivot hinges and/or floor closers.
- 8.1.2.5 Provide heavy-duty stainless-steel continuous hinges at all building main entry doors.
- 8.1.2.6 Bottom rails in glass doors shall be the industry standard. Custom height to be reviewed and approved by JMU prior to the completion of the Preliminary Design phase.
- 8.1.2.7 All access panels shall be fiberglass or metal. Provide access doors to attics, roofs, crawl spaces, valves, switches, concealed devices, tunnels and/or other similar areas where JMU personnel require access for maintenance or repair activities. Provide key locks on all access openings that are exposed to the public.

- 8.1.2.8 Interior side removable sashes are preferred for all operable windows for ease of cleaning and maintenance.
- 8.1.2.9 All wood doors shall have protective kick plates.
- 8.1.2.10 Floor or door-mounted stops shall not be used.
- 8.1.2.11 Wall-mounted concave door stops shall be provided with solid blocking.
- 8.1.2.12 Center mullion shall be installed at all double doors is preferred, unless the doors are on a hold open device. Center mullions shall be removeable and keyed with the doors.

### 8.1.3 Security

- 8.1.3.1 Provide security screens for ground level windows in residence halls, where allowed by code.
- 8.1.3.2 Locking and security hardware for perimeter of all buildings shall be a type that cannot be left in an unlocked position with a key from the outside (key from outside retracts latch bolt only – latch bolt engages as key is removed from cylinder). If egress is panic exit hardware, it shall be night latch (NL) function with “dog down” capability from inside by use of hex key. Use Von Duprin with Schlage trim or Von Duprin trim, verify with project manager.
- 8.1.3.3 Perimeter doors not requiring panic hardware shall be of the lever design (Schlage Rhodes or Sparta Design) with Schlage ND93JD vestibule lock where (unlatched by key from outside when lever is unlocked by key in inside lever. Inside lever is always unlocked) or Schlage ND96JD storeroom where outside lever is fixed. Entrance by key only. Inside lever is always unlocked.
- 8.1.3.4 All stairwell corridor doors with panic devices that are fire rated shall be of the type that stays latched at all times, even when in an unlocked position. If bored-in/tubular lever type, they shall be comparable to Schlage ND93JD, (key in the inside lever locks or unlocks outside lever), except where more security is required, then lever locks shall be comparable to Schlage ND96JD, where the outside lever is FIXED, (always in a locked position and key only retracts latch bolt). All such hardware to stairwell, mechanical/electrical and chemical storage rooms shall be abrasive coated, life safety code for handicapped, particularly vision impaired.
- 8.1.3.5 All locks on mechanical/electrical rooms and janitor closets shall be Schlage ND96JD, (fixed lever) in Rhodes or Sparta Design with a storeroom function.
- 8.1.3.6 All regular classroom locks shall be of the type that can only be locked from inside with a locking button and only a key shall unlock door from the outside, such as a Schlage ND94PD, Rhodes or Sparta Design.
- 8.1.3.7 All residence hall dormitory room locks shall be standard core ND92PD with vandal-guard function.
- 8.1.3.8 ND92 push turn levers for dorm rooms, offices, conference rooms, storage rooms and classrooms. All other rooms like janitor, mechanical, telecom, elevator need to have ND96 storeroom levers.
- 8.1.3.9 All other locks shall be as directed by owner, e.g. storeroom, passage or security alarm devices.
- 8.1.3.10 All keys shall be provided to the [JMU](#) locksmith, to include all construction keys, grandmaster, master and change keys.

- 8.1.3.11** All permanent key cylinders shall be purchased from Schlage by the JMU lock shop outside of the construction contract.
- 8.1.3.12** Card Reader Door Frames shall have properly sized mortar guards. Mortar guards shall be located at the electric strike, electric hinge, power transfer and door position switches. Mortar guards shall have a ½” conduit knockout to allow for conduit termination. All door frames designated as future card reader doors shall also have mortar guard as described.
- 8.1.3.13** All electric strikes or electrified panic hardware shall come with remote latch retraction function.
- 8.1.3.14** Magnetic locking devices shall not be used on any doors.
- 8.1.3.15** Schlage large format full size interchangeable cores (FSIC) or equivalent shall be used
- 8.1.3.16** Exit devices shall be Von Duprin or equivalent
- 8.1.3.17** Electrified exit devices over electronic strikes were available for access control.
- 8.1.3.18** LCN senior swing ADA operators or equivalent shall be used for all ADA doors.
- 8.1.3.19** Double doors shall only have only one lever set in order to avoid to prevent the doors from being chained shut

### 8.1.4 Performance

- 8.1.4.1** Double glazing is the minimum standard, however triple glazing for exterior windows and doors will be considered if shown to provide a positive payback.
- 8.1.4.2** All replacement glazing shall meet or exceed current energy code requirements for new installations.
- 8.1.4.3** All exterior doors shall be fully insulated and either fiberglass or thermally-broken steel or aluminum.
- 8.1.4.4** All exterior windows shall be either fiberglass or thermally-broken aluminum.
- 8.1.4.5** All steel doors shall be minimum of 16 gauge.
- 8.1.4.6** The extensive use of large curtain walls is not recommended. Where curtain or other high-percentage glazing walls are used, they shall be NFRC rated to provide a minimum total thermal resistance of at least R-6, including the frame and the glass.
- 8.1.4.7** All windows shall consider the use of shading devices.
- 8.1.4.8** All wood doors shall be solid-core with stain-grade veneer.
- 8.1.4.9** All metal door frames in new buildings are to be fully welded.
- 8.1.4.10** All doors shall carry a lifetime manufacturer’s guarantee.
- 8.1.4.11** Exterior metal door frames shall be thermally broken, unless prohibited by required fire ratings.

**(9.1) FINISHES**

**9.1.1 Ceilings**

- 9.1.1.1 All new suspended grid acoustical ceiling shall be a 2'x2' pattern. Preferred ceiling tiles shall be Armstrong 756A. **Tile selection to be reviewed and approved by JMU prior to the completion of the Preliminary Drawing phase.**
- 9.1.1.2 All acoustical ceiling tiles located in food preparation of food storage areas shall be vinyl coated
- 9.1.1.3 Renovations and/or additions shall match existing tiles.
- 9.1.1.4 Acoustical suspended grid system shall be 15/16" white minimum and of the highest quality available. Substitutions to be reviewed and approved by JMU prior to the completion of Preliminary Design phase.
- 9.1.1.5 Contractor to complete all above ceiling working prior to installing ceiling tile. During construction through warranty, no touchup paint on ceiling tile and grid, damaged tile and grid must be replaced.

**9.1.2 Walls**

- 9.1.2.1 High impact type gypsum board is preferred in high traffic areas requiring only moderate security.
- 9.1.2.2 Finish of gypsum wallboard system shall meet or exceed industry standards ASTM C-840 level 5 finish on all walls subject to natural or artificial light washing. A minimum of a level 4 finish for all other walls, Level 1 finish for wall 6" above ceiling to the to the deck above.

**9.1.3 Floors**

- 9.1.3.1 All floor tiles shall be a minimum of one-eighth (1/8") thick.
- 9.1.3.2 All floor tiles shall be laid in full mortar bed.
- 9.1.3.3 All resilient floor tiles shall be reinforced vinyl.
- 9.1.3.4 Provide non-skid, waterproof floor/wall system in kitchens and custodial closets.
- 9.1.3.5 The standard resilient base is a heavy-duty vinyl or rubber cove base with a minimum thickness of 0.125" and a minimum height of 4".
- 9.1.3.6 Outside corners shall be specified as pre-molded.
- 9.1.3.7 All carpet to be carpet tiles, 24 oz. per square yard minimum and solution dyed. Rolled goods to be reviewed and approved by JMU prior to the completion of the Preliminary Design phase.

**9.1.4 Paint**

- 9.1.4.1 Paints shall be top quality Low or No VOC latex. Contractor grade paint shall not be used. Preferred brands are Sherwin Williams or Benjamin Moore.
- 9.1.4.2 Provide semi-gloss paints to residence hall bedrooms, mechanical rooms, housekeeping closets, telecommunication rooms and maintenance storage rooms.
- 9.1.4.3 Provide semi-gloss epoxy paints in restrooms, hallways, high traffic areas and window sills.
- 9.1.4.4 All surfaces shall be pre-primed based on substrate in a color not matching the final coat. Use red oxide on galvanized surfaces.
- 9.1.4.5 All door frames shall have factory primer, field paint final coat to be gloss latex.

- 9.1.4.6** Gypsum walls to be primed with latex primers in a color not matching the final coat. Walls shall have two (2) applications of top quality Low or No VOC latex paints.
- 9.1.4.7** At the conclusion of the project, the contractor shall provide to JMU the supplier name, color, brand, mix formula, and location of each type.
- 9.1.4.8** All wood doors to have a factory finish. Finish to be reviewed and approved by JMU prior to ordering.
- 9.1.4.9** Paint shall be used at full thickness and shall only be thinned for required spraying applications. Spraying shall be pre-approved by JMU PM and shall always be back-rolled.

### (10.1) SIGNAGE

- 10.1.1** Install only the interior signage required by the authority having jurisdiction. Additional requested signage will need approval from Facilities Management prior to installation and must comply with the standards set forth in this division, 10.1 Signage.
- 10.1.2** Minimize the amount of wording on all signage, use of universal symbols is preferred.
- 10.1.3** Donor signage for a facility must be designed as part of the overall project as a specific donor signage master plan for the facility following the guidelines set forth in this division, 10.1 Signage. The donor master plan shall be reviewed and approved by Facilities Management prior to installation. Deviations from the specific facility donor signage master plan will not be approved.
- 10.1.4** All interior building signage shall be plastic laminate.
- 10.1.5** All signage shall be attached to walls with screws or approved sign holders. Signage shall not be attached to doors.
- 10.1.6** All signage for ceiling-enclosed sprinkler valves, fire dampers, alarms, transformers, primary isolation valves, etc. shall be clearly specified and attached to the ceiling or ceiling grid. The type of labeling must be approved by JMU.
- 10.1.7** Signage identifying room areas and functions shall be provided by JMU.
- 10.1.8** All room signage must meet ADA requirements.
- 10.1.9** Full room signs, with function at the top (4"x10") and departmental information (6"x10") are to be in 10"x10" frames. Restroom signage is to be 8"x8" and comply with the requirements of the authority having jurisdiction.
- 10.1.10** Sign tops (4"x10") must be matte finish, with raised letters, room numbers and the corresponding Braille. All working must meet SCHEV requirements.
- 10.1.11** Sign bottoms shall be engravable plastic.
- 10.1.12** Electrical, mechanical, telecom (mechanical), housekeeping and breakroom signs will be 4"x10" signs with frames.
- 10.1.13** Evacuation plans must be a minimum of 10"x10" and mounted in frames. The plans will show the building outline, room number, current location, evacuation route, pull station and fire extinguisher locations. The building name and emergency phone number will also be provided.
- 10.1.14** FACP, sprinkler control valve, main sprinkler control room, emergency communications, roof access, elevators and stair labeling/designation both interior and exterior signs are provided by JMU.
- 10.1.15** All exterior building signage is provided by JMU and must comply with JMU Campus Signage and Wayfinding Master Plan standards.
- 10.1.16** All exterior signage at roadways and pathways must comply with VDOT, the City of Harrisonburg and the JMU Campus Signage and Wayfinding Master Plan standards.

### (12.1) INTERIOR FURNISHINGS

#### 12.1.1 Furnishings

12.1.1.1 Furnishings shall be selected and purchased by JMU.

12.1.1.2 A/E shall coordinate space requirements and design for all selected furnishings.

#### 12.1.2 Window Coverings

12.1.2.1 Window coverings shall be designed to reduce cooling demand for the building.

12.1.2.2 All window coverings shall be included in the construction drawings.

12.1.2.3 Window covering standards for color and style shall be determined in the preliminary phase of the project and maintained throughout the building.

12.1.2.4 Minimum standard shall be 1" aluminum, commercial-grade blinds.

### (14.1) CONVEYING SYSTEMS

- 14.1.1 Preferred manufacturers are *Thyssenkrupp, Otis, or Schindler*. All other brands shall be pre-approved by JMU BST prior to consideration for design.
- 14.1.2 Final acceptance for elevators will require the contractor to coordinate with JMU's current Qualified Elevator Inspector (QEI) to conduct a full acceptance inspection and test in accordance with ASME/ANSI A17.1 before final acceptance by the owner. This inspection shall be completed and approved before the warranty period is placed in effect.
- 14.1.3 For telecommunication requirements in elevators see section (27.7).
- 14.1.4 All new elevators shall be "vandal-proof" and ADA compliant.
- 14.1.5 Cars shall be equipped with a hands-free telephone, exhaust fan, emergency lighting, protection pad hooks and one set of protection pads.
- 14.1.6 Elevator keys shall be provided to the project manager.
- 14.1.7 Elevators shall be stretcher-capable in multiple story buildings.
- 14.1.8 Elevator systems shall contain no proprietary equipment, software or diagnostics.
- 14.1.9 Elevator contractor shall provide at least two (2) sets of schematics, drawings and diagnostic tools. Complete copies of all diagnostic software shall be provided to JMU upon substantial completion. Software shall be provided on a tablet computer or self-contained device. If it is self-contained device, it shall be compatible with ALL elevators on campus of that brand.
- 14.1.10 Elevator pits for hydraulic elevators shall have sump pits with oil separators.
- 14.1.11 Sump pump shall contain an oil-sensing cutout and control system capable of pumping water, while containing oil. The system shall function automatically and shall provide for an alarm to the BAS and separate LED lights in the event of any of the following:
  - 14.1.11.1 Presence of oil in the sump
  - 14.1.11.2 High amps or a locked motor condition
  - 14.1.11.3 High liquid in the sump
- 14.1.12 Control panel shall include Led lights for power and pump run function.
- 14.1.13 All machinery and equipment shall be designed and installed to be accessible by maintenance personnel.
- 14.1.14 In order to more quickly add new elevators to the existing Elevator Service Contract, warranties for newly installed elevators should be minimized to no longer than 6 months from installation. Repair calls after that period will be handled by the Elevator Service Contractor and parts and service will fall under that negotiated contract. Building Safety Technologies will add the new elevators to the Elevator Service Contract at the end of the warranty period. Project Managers will need to provide the Warranty End Date to BST so as to prevent any gap in coverage.

### (21.1) FIRE SUPPRESSION

#### 21.1.1 General

- 21.1.1.1 At the completion of the project and/or final acceptance testing of the sprinkler system a copy of the certificate showing how the system functioned during the trip test shall be issued to the University.
- 21.1.1.2 Only one (1) manufacturer shall be specified for all fire stopping applications throughout the project.
- 21.1.1.3 Provide removal-warning label at all fire-stopping installations.
- 21.1.1.4 Provide floor drain in all sprinkler valve and pump rooms.
- 21.1.1.5 Add a heat detector in remotely located fire pump rooms to monitor for low temp/freezing condition.
- 21.1.1.6 Bolt down all incoming sprinkler lines from thrust block to flange with approved fasteners.
- 21.1.1.7 Install hydraulic placards at sprinkler riser with engraved data, not permanent marker.
- 21.1.1.8 Copper compression fittings shall not be used on sprinkler air compressor feeds.
- 21.1.1.9 All dry valves to be manually resettable without removing face bolts.
- 21.1.1.10 Connect fire pump controller to building generator.
- 21.1.1.11 Provide spare escutcheon plates for each type of escutcheon used in the building.

#### 21.1.2 FDC Requirements

- 21.1.2.1 All FDCs (remote or building mounted) must be provided on the front side of the building with approved signage visible from ALL directions. Where the FDC and signage are free standing, back-to-back post mounted signs are likely required to cover ALL directions. Where visibility is blocked, additional signage may be required.
- 21.1.2.2 Minimum 18"x18" metal sign with a red reflective background and white reflective letters and a 3/8-inch-wide white reflective border. Sign mounting height should be about 7 feet from grade level, directly behind and above the connections.
- 21.1.2.3 The address or addresses served by the connections (numbers, street and suite if applicable) must be illustrated with 2-inch letters on the top portion of the sign. The term "FDC" must be illustrated with at least 6-inch capital letters in the center of the sign (font to be "Arial" or equivalent).
- 21.1.2.4 The terms "Sprinkler Only" or "Standpipe Only" or "Sprinkler and Standpipe" must be illustrated in 2-inch letters on the bottom portion of the sign.
- 21.1.2.5 "Sprinkler Only" is required where the FDC only supports the building fire sprinkler system.
- 21.1.2.6 "Sprinkler and Standpipe" is required where the FDC supports hose valves inside the building as well as the building fire sprinkler system.

#### 21.1.3 Spare head box requirements

- 21.1.3.1 A list of the sprinklers installed in the property shall be posted in the sprinkler cabinet. The list shall include the following:
  1. Sprinkler identification number (SIN) if equipped, or the manufacturer, model, orifice, deflector type, thermal sensitivity, and pressure rating.
  2. General description
  3. Quantity of each type to be contained in the cabinet.

## DIVISION 21 – FIRE SUPPRESSION

4. Issue or revision date of the list.
- 21.1.3.2** The minimum information in the list contained in the spare sprinkler cabinet should be marked with the following:
1. General description of the sprinkler, including upright, pendent, residential, ESFR, and so forth
  2. Quantity of sprinklers to be maintained in the spare sprinkler cabinet

**(22.1) PLUMBING**

**22.1.1 General**

- 22.1.1.1 All water mains shall be buried to a minimum depth of 36" below grade.
- 22.1.1.2 All piping shall be contained within interior partition walls.
- 22.1.1.3 Freeze-proof wall hydrants shall be *Smith* brand, and extended stems shall be supplied from interior partitions perpendicular to exterior walls. The stem of the water shut-off valve shall extend at least 6" within the partition.
- 22.1.1.4 An as-built valve directory shall be installed in the mechanical room. All valves shall be individually numbered and tagged to correspond with valve directory.
- 22.1.1.5 Dielectric unions shall not be used. 6" long brass nipple shall be used when connecting piping of dissimilar metals.
- 22.1.1.6 Residence halls, Dining Halls and Athletic Facilities shall utilize steam generated or gas fired domestic water heaters.
- 22.1.1.7 For Gas Fired Domestic Hot Water Heaters see section 23.1.28.27
- 22.1.1.8 Administrative and other buildings may utilize electric domestic water heaters.
- 22.1.1.9 All isolation valves shall be ¼ turn, full-open ball valves.
- 22.1.1.10 Use the same manufacturer within the building for all plumbing components.
- 22.1.1.11 Linked neoprene seals shall be used in all piping sleeves that penetrate walls or slabs.
- 22.1.1.12 Sump pumps and/or sewage lift stations shall not be used. Elevator sump pumps are acceptable.
- 22.1.1.13 Double backflow assemblies shall be used on building services entry lines.
- 22.1.1.14 Backflow preventers shall be of the reduced pressure zone (RPZ) type. The assembly shall include shut off valves on inlet and outlet, and strainer on inlet. Backflow preventers shall include test cocks and pressure-differential relief valve located between two (2) positive seating check valves.
- 22.1.1.15 Backflow preventers shall be mounted approximately 3'-4' above the floor and be readily accessible for maintenance.
- 22.1.1.16 Backflow preventers shall be located inside a heated building.
- 22.1.1.17 All backflow preventers shall have inlet and outlet water shut-off valves outside of the assembly and include union connections.
- 22.1.1.18 All new gas food service equipment needs to be equipped with a thermocouple control automatic ignition and not a standing pilot for safety of lighting pilots.

**22.1.2 Water Service (Exterior)**

- 22.1.2.1 Underground water supply services to new construction or additions shall be ductile iron pipe, type K copper or 200 psi black plastic tubing (PE or PEX) in special applications. Above ground water piping above ground shall be type L copper.
- 22.1.2.2 All buildings shall be supplied with a main water cutoff valve within 10' of an exterior wall of the building.
- 22.1.2.3 Static water pressure test at hydrants shall be performed by A/E or their designee.
- 22.1.2.4 Exterior wall hydrants are to be provided every 100' along walls and shall be equipped with automatic integral backflow preventers.
- 22.1.2.5 Wall hydrants shall be concealed, freeze-proof and automatic draining with a key lock.
- 22.1.2.6 Cut off valves shall be within 5' of every fire hydrant.

- 22.1.2.7 Fire hydrants proposed at locations subject to probable vehicular impact shall be protected by six inch raised curb island designs, wherever practical, or by guard post or other barrier designs. Guard post minimum requirements:
  - 22.1.2.7.1 Constructed of steel not less than 4" in diameter and concrete filled.
  - 22.1.2.7.2 Spaced not more than 4' between posts on center.
  - 22.1.2.7.3 Set not less than 3' deep centered in a concrete footing of not less than a 15" diameter.
  - 22.1.2.7.4 Set with the top of the post not less than 3' above ground.
  - 22.1.2.7.5 Located not less than 3' from the fire hydrant.
- 22.1.2.8 All valve boxes shall be raised to ground level.
- 22.1.2.9 All exterior drinking fountains shall be frost proof type.
- 22.1.2.10 All hardware shall be stainless steel.

### 22.1.3 Water Service (Interior)

- 22.1.3.1 Shut-off valves shall be located on each floor, take offs from all vertical risers, branch lines from the main and at the connection to each fixture or piece of equipment.
- 22.1.3.2 Isolation valves to all bathroom units, kitchens and all equipment shall be IPS threaded.
- 22.1.3.3 Pressure reducing valves shall be provided in all buildings at the domestic water entrance downstream of the meter and provide a full size by-pass loop around the PRV and meter.
- 22.1.3.4 Pressure regulating valves shall be single seated, direct operated type, bronze body, integral strainer, complying with requirements of ASSE standard 1003. Provide inlet and outlet shutoff valves and by-pass valve. Provide pressure gauge on valve outlet.
- 22.1.3.5 Domestic water meters shall be installed in each building. Irrigation system shall be metered separately.
- 22.1.3.6 All bathrooms, mechanical equipment rooms, glycol tanks and cooling towers shall be equipped with a hose bib. Public bathrooms shall include a key-operated hose bib.
- 22.1.3.7 Provide "screwdriver-style" lockable access doors for all isolation valves, hammer arrestors and trap seal primer valves serving the domestic water systems.
- 22.1.3.8 All backflow preventers shall be installed below adjacent permanently installed electrical equipment. Adequate provisions shall be made to catch leaks and provide direct discharge to the floor drain.
- 22.1.3.9 Faucets shall be solid brass construction with vandal-proof aerator and be single or two handle Delta or equivalent.
- 22.1.3.10 Water closets and urinals shall have a Sloan manual flushometers.
- 22.1.3.11 All automatic flushing sensors shall be battery operated and include a manual override. A Sloan Flush valve or equivalent with side Mounted sensor in the place of handle for commodes and Urinals EVB-89A-M style
- 22.1.3.12 Faucets that are sensor operated shall be Chicago E-Tronic 116.606.ab.1 with a Chicago mixing valve 242.165.ab.1 or equivalent.
- 22.1.3.13 Soda drinking stations shall have PVC drains installed to a length that the syrup is flushed/diluted prior to entering and cast type sewer drains Lavatories, sinks and

water coolers to have threaded 1.5" chrome plated cast p-traps with cleanouts and brass escutcheons.

- 22.1.3.14 All bathroom fixtures shall be caulked with 100% white silicone sealant.
- 22.1.3.15 All exposed piping in toilet rooms shall be chrome plated brass.
- 22.1.3.16 All plumbing penetrations in wall shall be caulked airtight with acoustical caulk.

### 22.1.4 D/W/V

- 22.1.4.1 All below grade storm and/or sanitary drainage piping shall be PVC or epoxy-coated cast iron, except specifically designed acid-resistant or high-temperature waste drains.
- 22.1.4.2 All urinals shall have sch40 PVC piping to the main drain.
- 22.1.4.3 Drains shall be provided in all sprinkler valve rooms, restrooms, cooling towers, mechanical rooms, or any other area subject to continuous or intermittent wetting.
- 22.1.4.4 All above ground gravity storm and sanitary drains shall be cast iron, except those serving grease-laden or harsh chemical waste.
- 22.1.4.5 Wall cleanouts in corridors are preferred to floor cleanouts where possible. Cleanouts shall be adjustable and equipped with an internal brass plug with counter sunk brass screws holding rim to body cover. Wall cleanouts shall be stainless steel round access covers.
- 22.1.4.6 All cleanouts at or above the ceiling shall be brought to the floor level of the fixture being served.
- 22.1.4.7 Acid waste piping above ground shall be flame-retardant schedule 40 polypropylene with socket fusion fittings. Mechanical joints allowed only under lab benches inside accessible cabinets and not in cabinet pipe chase. Below ground piping shall be schedule 80 polypropylene with socket fusion fittings.
- 22.1.4.8 All sinks requiring indirect drainage shall discharge via an air gap into a sufficiently sized floor sink.
- 22.1.4.9 PVC closet flanges shall not contain metal components.
- 22.1.4.10 All fixtures shall be vented to the exterior; AAV's shall not be used for venting.

### 22.1.5 Valves & Fixtures

- 22.1.5.1 Waterless urinals shall not be permitted, except when directed by JMU.
- 22.1.5.2 All lavatories shall have molded overflows. Hose connections shall not be used.
- 22.1.5.3 Lavatory faucets shall only use 4" center faucets with single lever commercial heavy duty brass.
- 22.1.5.4 Sinks shall be counter mounted, self-rimming 18 gauge stainless steel with an 8" depth, not to interfere with ADA requirements.
- 22.1.5.5 Sink faucets shall be 8" single lever commercial heavy-duty brass.
- 22.1.5.6 Sink and lavatory faucets shall be Delta brand.
- 22.1.5.7 All fixtures that serve hot and cold water to a combined outlet such as a spray hose assembly or a garden hose thread outlet shall include check valves on both the hot and cold water supply lines, or integral check valves for both hot and cold water in the fixture itself, in order to prevent cross connection of hot and cold water systems when both valves are left open with an accessory blocking the outlet. Fixtures that include a single check valve for the combined outlet only will not be sufficient for this purpose.

- 22.1.5.8** Electric water coolers shall be electric push button or push bar and all stainless steel exterior, including skirt.
- 22.1.5.9** Provide chilled bottle filling stations at all water coolers.
- 22.1.5.10** All shower valves shall be *Symmons* brand.
- 22.1.5.11** Shower Valves shall include the following items:
  - 22.1.5.11.1** Single lever operated pressure balance anti-scald valve with integral stops and tamper proof water saver shower head
  - 22.1.5.11.2** Valve body and internal components are all brass, bronze and stainless steel, and lever handle, chrome plated bronze with stainless steel set screw
  - 22.1.5.11.3** Heavy-duty ½" diameter control spindle
  - 22.1.5.11.4** Compression-type shut-off
  - 22.1.5.11.5** Positive shut-off of at both hot and cold entering water to eliminate free possibility of by-pass of hot to cold
  - 22.1.5.11.6** Handle movement shall provide 360° rotation.
  - 22.1.5.11.7** Positive accurate pressure balancing control with stainless steel precision around piston.
- 22.1.5.12** Shower heads shall be heavy duty, solid brass and chrome-plated with no removable parts.
- 22.1.5.13** Off-site fabricated shower basins shall be of solid polymer construction. Shower stall walls shall be finished with ¼" solid surface polymer panels. Panels shall extend at least 2" below top of threshold of shower basin on all walls in shower stall. Panel and base material shall be from the same manufacturer.
- 22.1.5.14** Installation of shower basin connections to drains through slab shall be properly aligned and water tight. All basin connections shall be readily accessible.
- 22.1.5.15** Shower valves and shower heads shall be installed on a sidewall in the shower unit so that the spray from the shower head does not spray toward the threshold or shower curtain.

## DIVISION 23 – HEATING VENTILATING AND AIR CONDITIONING

### (23.1) MECHANICAL

#### 23.1.1 Design

- 23.1.1.1 All mechanical equipment shall be designed to utilize existing building systems; e.g. chilled water, heating water, VAVs, etc.
- 23.1.1.2 The indoor design temperature for the cooling season shall be 74°F.
- 23.1.1.3 The indoor design temperature for the heating season shall be 72°F.
- 23.1.1.4 Outdoor design temperatures shall use the 2% cooling season temperatures from ASHRAE Fundamentals.
- 23.1.1.5 Outdoor design temperature for heating season shall use 0°F.
- 23.1.1.6 Cooling season equipment shall be principally designed to consider the effects of part-load cooling season conditions and their ability to provide proper dehumidification. Buildings or zones with extended unoccupied time; e.g. academic or dorm buildings in the summer, shall be able to maintain 50% RH at an 85°F setback temperature.
- 23.1.1.7 All equipment and duct design for academic buildings shall provide for the potential for the change of use within a given space; i.e., classrooms that change to computer labs, etc. Takeoffs from the main trunk shall be located in an accessible area.
- 23.1.1.8 Equipment and ducts shall be located within the thermal envelope of the building whenever practicable.
- 23.1.1.9 Systems shall be sized to provide required heating and cooling in the event of heat/energy recovery system failure.
- 23.1.1.10 Student housing shall use the following features as the basis for design:
  - 23.1.1.10.1 4-pipe system
  - 23.1.1.10.2 BAS controlled thermostats
  - 23.1.1.10.3 FCUs in closets only accessible from the corridor

#### 23.1.2 General

- 23.1.2.1 NEMA premium efficiency motors shall be used on all HVAC systems at [JMU](#).
- 23.1.2.2 Any cooling tower system, AHU or other piece of equipment that requires a ladder greater than 8' tall to service shall be provided with permanently installed ladders and service platforms.
- 23.1.2.3 Contractors shall provide training and the manufacturer's service manuals for all equipment installations.
- 23.1.2.4 Unit information labels and stickers shall never be painted over or covered in any way.
- 23.1.2.5 The location of mechanical equipment above acoustical ceilings shall be identified by small laminated plastic (black & white signs attached to ceiling grid).
- 23.1.2.6 Include noise criteria for all fan units. (See section 2.4 for acoustical requirements.)
- 23.1.2.7 Duct lining is prohibited, except as required for sound attenuation.
- 23.1.2.8 Buildings shall always be designed to use an economizer mode when outside air is below 50°F for cooling in the winter. Buildings with fan coil units shall be able to utilize some means of economized cooling and be able to maintain the set point.
- 23.1.2.9 Design hot water system with two-way valves when using primary and secondary hot water loop.
- 23.1.2.10 All circuit setters shall be externally adjustable. Pressure independent valves shall not be used.

## DIVISION 23 – HEATING VENTILATING AND AIR CONDITIONING

- 23.1.2.11 Hot water systems shall be isolated from each other; i.e. Fan coil units, AHUs and perimeter radiant panels shall be on separate systems to allow for different reset schedules.
  - 23.1.2.12 No dielectric unions shall be used. Use dielectric pipe nipples in their place.
  - 23.1.2.13 Small HVAC systems that are not connected to the BAS system shall have a thermostat with automatic changeover installed. The thermostat shall automatically switch from heating to cooling and back to satisfy the space heating and cooling needs.
  - 23.1.2.14 All indoor and outdoor equipment areas shall have lighting that can be turned on by the workers when needed. This includes HVAC equipment areas on a roof, enclosures and any such areas where ambient light is not available.
  - 23.1.2.15 During construction and renovations the HVAC systems shall be turned off and all supply, return and equipment openings shall be covered. If the area of construction or renovation requires heating or cooling during the project, it shall be the responsibility of the contractor to provide and install temporary HVAC systems to meet this need. Only when the project is complete shall the building HVAC system's operation be restored. If air filters need replacement or equipment, duct and/or coils need cleaning, it shall be the responsibility of the contractor.
  - 23.1.2.16 Paint all un-insulated piping, duct work and supporting structures that are exposed to outdoor weather conditions.
  - 23.1.2.17 Pipes and conduits shall not cross any designated roof walkways. If they must cross a walkway, a permanent accessible and readily removable platform and/or stairs shall be provided over the piping.
- 23.1.3 Location and Equipment**
- 23.1.3.1 The A/E shall provide safe access and manufacturer's recommended working clearances for all equipment.
  - 23.1.3.2 In phased projects, mechanical rooms shall be sized to include equipment for all future phases.
  - 23.1.3.3 Removal and/or replacement of the largest piece of equipment shall not require the removal of any permanent walls or other functioning equipment.
  - 23.1.3.4 Mechanical equipment, piping and conduit shall provide acoustical isolation from walls, floors and ceilings.
  - 23.1.3.5 Water-tight, auxiliary drain pans shall be installed under every type of equipment that has water or has the potential to generate condensate, when the equipment is located overhead. Pans shall be piped to drain and shall not share the same piping as the equipment. If a pan cannot be installed, a condensate switch shall be installed in the main drain pan.
  - 23.1.3.6 Equipment, piping, ducts, drain pans, and any other related items shall not block service access.
  - 23.1.3.7 All waterlines exposed to cold weather shall be heat traced.
- 23.1.4 Metering**
- 23.1.4.1 (see BAS section [21.15](#))
- 23.1.5 Ventilation/Outdoor Air (OA)**
- 23.1.5.1 Outdoor air shall be determined by ASHRAE 62.1 standards.

## DIVISION 23 – HEATING VENTILATING AND AIR CONDITIONING

- 23.1.5.2 OA shall be set so as not to exceed the requirements of ASHRAE 62.1.
- 23.1.5.3 Assembly areas shall be equipped with dedicated AHUs with modulating OA and RA damper controls. Dampers shall be set to no less than the minimum OA volume and be allowed to modulate from minimum to fully open between 800ppm and 1200ppm of CO<sub>2</sub> return air concentration.
- 23.1.5.4 Fresh air ventilation units shall be from a reputable vendor, capable of making emergency service calls within a 24 hour notice.

### 23.1.6 Water Treatment

- 23.1.6.1 JMU has a contract with a vendor to provide water treatment for all of our heating water, cooling water, and cooling tower systems.
- 23.1.6.2 Chemicals for the cleaning/flushing of systems, inhibitors, biocides, chemical controllers, glycol and feed systems are part of this contract.
- 23.1.6.3 Any projects that require HVAC water treatment shall use the JMU contracted vendor for all water treatment equipment and related services and supplies.
- 23.1.6.4 All closed water loops shall be flushed prior to their operation.
- 23.1.6.5 All closed water loops shall have a 20" filter feeder installed to allow filtering of closed loop as well as feeding chemicals. Filter Feeders are available through the JMU water treatment provider.
- 23.1.6.6 Cooling tower chemical controls for water treatment shall be installed. Chemical control system shall be designed to be inter-locked with condenser water pump.
- 23.1.6.7 Chemical feed for cooling towers shall be piped into a chemical station manifold, which shall include a conductivity sensor, injection ports for chemicals, a flow switch, and a sampling port for taking weekly samples. This chemical station shall have isolation valves that are located at the chemical station.
- 23.1.6.8 All chemical station piping shall be sch80 PVC that terminates to brass ball valves at the point of connecting to condenser water lines.
- 23.1.6.9 Cyclonic separators shall be installed to help remove heavy solids from the cooling tower water. An independent electronic timer that is interlocked with the condenser pumps shall be used to control the blow down valve. A full-flow blow down valve shall also be installed.
- 23.1.6.10 Water treatment specification shall be included system design. This is available upon request from the JMU HVAC department.

### 23.1.7 Cooling Towers

- 23.1.7.1 Hot and cold water basins and distribution boxes shall be constructed with stainless steel. Stainless steel cooling towers are preferred.
- 23.1.7.2 Basin heaters shall be installed.
- 23.1.7.3 Float valves are the preferred tower makeup water control. A pressure reducing valve shall be installed in series with the makeup water valve.
- 23.1.7.4 Ladders, cages, rails and catwalks shall be installed for safe access for the service and repair of the cooling tower.
- 23.1.7.5 Proper passivation of the tower shall be performed by the cooling tower manufacturer and the JMU water treatment provider.

## DIVISION 23 – HEATING VENTILATING AND AIR CONDITIONING

**23.1.7.6** All cooling towers shall be started by the cooling tower manufacturer's service representative. A JMU HVAC shop representative shall be present for the startup. Prior notice of 72 hours shall be given for all cooling tower start-ups.

**23.1.7.7** Equalizer lines shall have bottom-drains allowing complete drainage.

### **23.1.8 Air Handling Unit (AHU) and Roof Top Unit (RTU)**

**23.1.8.1** All HVAC air handlers located in a building above the ground floor level should have water tight curbing located around them with floor drain inside curbing. Water circulating pumps should be inside of curbing. This does not apply to RTUs.

**23.1.8.2** AHUs that are larger than 20 tons in cooling capacity shall have lights installed in the interior of units with a switch on outside of unit with pilot light.

**23.1.8.3** Air handling units shall be of double wall construction.

**23.1.8.4** Service access panels shall be constructed with side-hinged doors.

**23.1.8.5** Shall have stainless steel drain pans with pans sloped to drain all water from pan.

**23.1.8.6** Install thermometers and pressure gauges at pumps and AHU's water lines. Thermometers should be of solar power variety.

**23.1.8.7** JMU shall provide an updated BAS specification to each project.

**23.1.8.8** All fans shall be dynamically and statically balanced at factory.

**23.1.8.9** Contractor to provide two (2) sets of 30% efficient, pleated-type filters for each unit requiring filter sections.

**23.1.8.10** All dampers shall be rated for a maximum leakage rate of <1% of nominal CFM at 1" W.C.

**23.1.8.11** Outdoor air intakes shall use ½" hardware cloth instead of insect screens.

**23.1.8.12** Access panels shall be a minimum of 18"x18" with a hinged door. Access doors shall be able to open fully and be installed in such a way as to be free from sharp edges and protruding screws.

**23.1.8.13** Do not use face and bypass dampers.

**23.1.8.14** All AHU coils shall be filtered to include pre-heat, pre-cool and ERV coils.

**23.1.8.15** DX cooling in a VAV or multi-zone system is not acceptable.

**23.1.8.16** AHU's shall have preheat coils on outside air and should preheat outside air from 0°F to 45°F before entering the mixing chamber. Do not use separate ducting for minimum outside air. Use maximum outside air duct being used for economizer with minimum position on dampers for min OA.

**23.1.8.17** All pre-heat, heating or re-heat coils shall be hot water.

**23.1.8.18** The preferred heat recovery systems are tube in tube style.

**23.1.8.19** On AHUs, reheat boxes, unit ventilators and any piece of equipment with the capacity to heat or cool, the heating valve or damper shall be normally open and the cooling valve or damper should be normally closed.

**23.1.8.20** RTUs with exposed ductwork above roof grade shall have duct work insulated in a fashion that the top of the duct insulation is pitched to allow water to drain off the top of the duct. Wrap the duct insulation with a self-sealing membrane. Duct insulation wrapped with self-sealing membrane must be sealed at all areas of penetration, such as duct supports or stands.

## DIVISION 23 – HEATING VENTILATING AND AIR CONDITIONING

- 23.1.8.21 RTUs shall have ductwork designed in a fashion as to not block the access to units. Crawling under ductwork or having to climb over ductwork is unacceptable to access a unit.
- 23.1.8.22 If unit mounted disconnects are used, another means of disconnect shall also be included that is separate from the AHU or RTU, but located adjacent to the AHU or RTU.
- 23.1.8.23 Water circulation pumps shall not be installed between the suspended ceiling and the RTU.

### 23.1.9 Fan Coil Units (FCU)

- 23.1.9.1 All FCUs shall have a filter rack or filter grill capable of using an air filter at least 1" thick, and is required to use a pleated type with 30% efficiency.
- 23.1.9.2 All ceiling mounted ducted fan coils shall use a filter grill.
- 23.1.9.3 All ceiling mounted FCUs shall be equipped with a float switch that shall stop the cooling operation in the event of a primary condensate pan overflow.
- 23.1.9.4 Sound blankets of any kind should never be used on ceiling mounted fan coil units.
- 23.1.9.5 FCU condensate drains shall be piped to a gravity drain. Condensate pumps shall be avoided when possible.
- 23.1.9.6 FCU mounted disconnects are allowed, however, another means of disconnect shall be included that is separate from the fan coil and is located adjacent to the fan coil.
- 23.1.9.7 Spare parts may be requested by the JMU HVAC department for large projects.

### 23.1.10 Variable Air Volume (VAV)

- 23.1.10.1 Fan powered boxes are not acceptable. Use induction reheat or terminal boxes.
- 23.1.10.2 Zone control shall be used for optimization of equipment.
- 23.1.10.3 Reheat coils shall be a two-pass design.
- 23.1.10.4 Reheat coil shall be equipped within isolation valves, strainer, flow control and control valves.
- 23.1.10.5 All systems shall have variable frequency drives (VFD) on the fan(s).

### 23.1.11 Exhaust and Make-up Air Fans

- 23.1.11.1 Any exhaust system set up with a HRV or ERV coils shall have a filter rack immediately prior to the coil
- 23.1.11.2 Any exhaust system set up with a heat or energy recovery coil shall have an access door to access the coil for cleaning.

### 23.1.12 Pumps (heating, chilled and condenser water)

- 23.1.12.1 All pumps shall have isolation valves installed.
- 23.1.12.2 All pumps shall have strainers installed on the suction inlet.
- 23.1.12.3 Condenser water pump strainers shall be stainless steel and include isolation valves.
- 23.1.12.4 Pumps shall be installed at floor level, with the exception of pumps on AHUs. Consideration for other locations shall depend on the pump's accessibility and water damage prevention measures during a pump failure.
- 23.1.12.5 Cooling tower chemical pumps shall be provided by the JMU water treatment provider and they shall also specify how such pumps are to be installed.

## DIVISION 23 – HEATING VENTILATING AND AIR CONDITIONING

- 23.1.12.6 Provide redundant pumps for all building heating water, chilled water, and condenser water systems.
- 23.1.12.7 Install thermometers and pressure gauges at all pumps. Thermometers should be of the solar powered variety.

### 23.1.13 Split System (HVAC and Refrigeration)

- 23.1.13.1 Variable refrigerant volume (VRV) and variable refrigerant flow (VRF) systems are prohibited and shall not be installed on the JMU campus.
- 23.1.13.2 Prior to equipment installation all refrigerant lines shall be capped and never open to the environment.
- 23.1.13.3 Refrigerant lines shall be sized and installed as per the manufacturer's installation instructions.
- 23.1.13.4 Brazed connections are preferred on all refrigerant lines on HVAC split systems. If other means of connecting line are used, they shall be of an approved method by the equipment manufacturer.
- 23.1.13.5 A standing pressure test of all refrigerant piping shall be performed while the lines are fully accessible and before the equipment is connected. All refrigerant lines shall hold a nitrogen charge of 500psig for 24 hours. An approved JMU representative shall witness this pressure test. Once the test is completed successfully, the lines may be covered and the equipment installed. On existing buildings when split systems are added, this pressure test may be waived if approved by JMU HVAC department.
- 23.1.13.6 Final refrigerant line connections at the equipment shall also be tested for leaks with a standing pressure test before insulating, evacuation and charging. The final connections shall hold a nitrogen charge for 24 hours. The nitrogen charge shall not exceed the manufacturer's test pressure rating. An approved JMU representative shall witness this pressure test. Once the test is completed successfully the lines may be insulated and you may proceed with evacuation and charging.
- 23.1.13.7 Split systems shall be properly evacuated to remove air and moisture. All systems shall be evacuated as per the manufacturer's specifications.
- 23.1.13.8 After the system is charged, labeling shall be installed on the condensing unit with system full charge and refrigerant type listed.
- 23.1.13.9 Labels shall be installed that identifies which equipment (condensing unit and evaporator) that operate together as one system. Power source labeling is also needed.

### 23.1.14 Air Filters

- 23.1.14.1 All air filters shall be a pleated type filter with a 30% efficiency. Exceptions will be considered for equipment that requires the use of specialty filters such as bag or HEPA filters.
- 23.1.14.2 All coils shall be filtered.
- 23.1.14.3 Two (2) additional set of air filters shall be provided on all HVAC projects.
- 23.1.14.4 We purchase air filters under a contract and you are welcome to contact our filter supplier to purchase the type and quality of filter that we use.
- 23.1.14.5 Weatherproof filter storage shall be provided within reasonable proximity of filter-use locations.

## DIVISION 23 – HEATING VENTILATING AND AIR CONDITIONING

23.1.14.6 Mechanical contractor shall provide part number, sizing, and quantity for all filters and belts.

### 23.1.15 Pipe Insulation

23.1.15.1 *Armflex AP* insulation shall be used on copper pipes for temperatures <180°F.

23.1.15.2 Fiberglass insulation shall be used for temperatures >180° F.

23.1.15.3 Armflex and closed cell insulation should never be used on black pipe that is carrying dual temperature or chilled water.

23.1.15.4 All pipe insulation that is exposed to outdoor weather shall be covered with an aluminum jacket or self-sealing membrane and sealed.

23.1.15.5 Other types of pipe insulation shall be considered on the basis of pipe construction, location and temperature of liquid in the pipe.

### 23.1.16 Refrigeration Equipment , Ice makers & Water Filters

23.1.16.1 Air-cooled icemakers shall be installed per manufacturer’s ventilation requirements.

23.1.16.2 Ice makers shall never be installed in unheated spaces.

23.1.16.3 Filters shall be installed on the water supply lines for all icemakers, drink stations, and steamers.

23.1.16.4 The preferred ice filter is the Everpure I-2000 filter. The preferred drink station filter is the Everpure MC filter. The preferred steam filter is the Everpure Kleen Steam. All other filters shall be approved by JMU prior to use.

23.1.16.5 Pre-manufactured line set equipment shall follow the manufacturer’s installation instructions.

23.1.16.6 Custom-built refrigeration equipment is not acceptable unless pre-approved by the JMU FM Refrigeration Department.

23.1.16.7 Pull-out drawers shall not be used.

23.1.16.8 Drain lines for ice machines and bins shall be run separately.

### 23.1.17 Refrigerant Monitors

23.1.17.1 Only *Bacharach* monitors shall be used.

23.1.17.2 All strobes used in conjunction with the refrigerant monitor shall be amber in color.

23.1.17.3 Refrigerant monitors shall be interfaced with the JMU BAS and is part of the BAS specifications.

23.1.17.4 JMU has received an exemption and is not required to have self-contained breathing apparatus or SCBA at the mechanical room entrance. Further questions regarding SCBA requirements can be directed to the office of University Risk Management.

23.1.17.5 The signs on the mechanical room doors shall say the following:

**DO NOT ENTER!**

POTENTIAL OXYGEN DEFICIENT ATMOSPHERE WHEN ALARM IS ACTIVE.

PLEASE NOTIFY PUBLIC SAFETY AT 568-6911 AND FM WORK CONTROL AT 568-6101

IMMEDIATELY FOR PROPER RESPONSE.

### 23.1.18 Refrigerant & Refrigerant Management

23.1.18.1 The following are the only acceptable HVAC refrigerants:

23.1.18.1.1 R-134A

## DIVISION 23 – HEATING VENTILATING AND AIR CONDITIONING

23.1.18.1.2 R-410A

23.1.18.1.3 R-514A

23.1.18.1.4 R-1233ZD

23.1.18.2 The following are the only acceptable refrigeration refrigerants:

23.1.18.2.1 R-134A

23.1.18.2.2 R-404A

23.1.18.3 Low-pressure refrigerants shall be considered first.

23.1.18.4 All refrigerant work (including disposal) shall comply with EPA Section 608 regulations.

23.1.18.5 Documentation of all refrigerant activity (including disposal) shall be submitted to the JMU HVAC manager. Forms and instructions are available from the JMU HVAC manager and supervisors.

23.1.18.6 Properly certified technicians shall perform all work and shall have proof of certification with them at all times when they are on the job site.

23.1.18.7 Documentation for all technician certifications shall be filed with the JMU HVAC manager.

23.1.18.8 The JMU HVAC shop shall provide all cylinders needed for the recovery of refrigerant for disposal. A two (2) week notice is required prior to recovery of refrigerant. JMU shall not provide any recovery equipment for contractor use.

### 23.1.19 Chillers

23.1.19.1 Chillers with open drive compressors shall not be used.

23.1.19.2 Where practicable, the use of multiple small chillers shall be considered in lieu of a single, large chiller.

23.1.19.3 Removable sound blankets and sound enclosures for sound attenuation shall not be used.

23.1.19.4 Oil-free and magnetic centrifugal chillers shall only be used when pre-approved by the JMU HVAC department.

23.1.19.5 Chillers using variable speed technology for capacity control may be used.

23.1.19.6 Scroll compressors shall not be used on chillers with capacities >145 tons.

23.1.19.7 Chillers over 145 tons shall have screw or centrifugal compressors.

23.1.19.8 Dual refrigerant circuits and compressors shall be considered.

23.1.19.9 Water-cooled chillers shall be capable of controlling the condenser water pump, chilled water pump, tower by-pass valve and cooling tower fan.

23.1.19.10 Chillers shall use a primary and secondary pumping system. The chiller shall control the primary chilled water pump.

23.1.19.11 All chillers shall be monitored by the JMU BAS system and include BACnet/IP communication capabilities. The BAS system shall provide stop and start commands to the chiller.

23.1.19.12 All water cooled chillers shall have a cooling tower by-pass valve installed.

23.1.19.13 All chiller shall be started by the chiller manufactures service representative. A JMU HVAC shop representative shall be present for the startup. Prior notice of 72 hours shall be given for all chiller start-ups.

23.1.19.14 Manufacturer shall provide training for two JMU HVAC technicians at their offsite training facility.

## DIVISION 23 – HEATING VENTILATING AND AIR CONDITIONING

- 23.1.19.15 Chiller mounted disconnects are acceptable, however, another means of disconnect shall also be included that is separate from the chiller, but located adjacent to the chiller.
- 23.1.19.16 Pressure gauges and thermometers shall be installed on chiller evaporators and water cooled condensers. Thermometers shall be solar powered.
- 23.1.19.17 Air cooled chillers shall have manufacturer installed freeze protection.
- 23.1.19.18 All evaporators and water cooled condensers shall have isolation valves and drain valves installed. They shall also have a 1.5” threadolet installed with a plug between each of the isolation valves and the heat exchanger.
- 23.1.19.19 Some buildings may need to be designed with emergency hookups for rental chillers. When a building is being designed, the question will need to be asked whether the building is mission critical and shall require any emergency connections.
- 23.1.19.20 All chillers shall be supplied with all software and cables needed for servicing and troubleshooting.
- 23.1.19.21 All piping connections at the chiller heat exchangers shall use Victaulic or flanged connections, and require minimal pipe removal for repair.

### 23.1.20 Variable Frequency Drives (VFD)

- 23.1.20.1 VFDs shall be interfaced with the JMU BAS.
- 23.1.20.2 All VFDs shall be *Danfoss VLT* brand.

### 23.1.21 Glycol

- 23.1.21.1 Propylene Glycol shall be used where freeze protection is required. Certain applications may require “food-grade” propylene glycol to be used.
- 23.1.21.2 33% glycol should give adequate freeze protection on most systems.
- 23.1.21.3 Glycol and feed systems can be purchased from our water treatment supplier.
- 23.1.21.4 A hose bib shall be installed within 20’ of the glycol feed tank.
- 23.1.21.5 If a system requires glycol, it shall also have an automatic feed system.
- 23.1.21.6 Closed-loop system relief valves shall be piped back to the make-up tank.
- 23.1.21.7 The low glycol level sensor on the feed tank shall be wired into the BAS.

### 23.1.22 HVAC Controls

- 23.1.22.1 HVAC systems shall be interfaced with the JMU BAS for control and monitoring. Smaller units, split systems and thru-wall units may be exempt and will use unit mounted controls.

### 23.1.23 Main Frame IT Computer Room HVAC Systems

- 23.1.23.1 All rooms shall have 50% capacity of redundant cooling.
- 23.1.23.2 Chilled water may be used from an independent chiller that is capable of operating continually.
- 23.1.23.3 All IT room HVAC systems shall be connected to the emergency generator, including the back-up (or redundant) system.
- 23.1.23.4 IT main frame computer HVAC systems shall be entirely independent and in no way connected with any other building systems.
- 23.1.23.5 Infrared humidifiers are the preferred type of humidifier to use in IT HVAC systems.
- 23.1.23.6 All HVAC systems and room conditions shall be monitored by the JMU BAS.

## DIVISION 23 – HEATING VENTILATING AND AIR CONDITIONING

### 23.1.24 Environmental Chambers

- 23.1.24.1 Environmental chambers are used to meet the program needs of the end user in a building. In most cases, the JMU Refrigeration shop will provide service and repair after the chamber is installed and put in operation.
- 23.1.24.2 Air-cooled equipment shall never be installed without proper ventilation. Refer to the manufacturer's installation requirements for needed ventilation.

### 23.1.25 Specialty HVAC Systems Applications

- 23.1.25.1 Specialty systems may need to be designed to meet the program needs of the end user in a building. In most cases, the JMU HVAC shop will provide service and repair after the system is installed and put in operation.
- 23.1.25.2 All specialty HVAC systems shall be tested, balanced and commissioned to ensure that the system will perform as designed.
- 23.1.25.3 All specialty HVAC equipment and systems shall be designed with redundancy in mind.
- 23.1.25.4 If the system is mission critical and used for research, it shall be able to operate independently from any other building systems. It shall be able to automatically resume operation during an interruption from any utilities to the building; e.g. power, water, steam, hot water, chilled water, etc.
- 23.1.25.5 Air-cooled equipment shall never be installed without proper ventilation. Refer to the manufacturer's installation requirements for needed ventilation.

### 23.1.26 Identification of Equipment and Valves

- 23.1.26.1 Tag valves with 1.5" diameter brass tag with depressed black-filled numbers ½" high. Fasten tag to valve with brass "S" hook or brass jack chain. Tags shall be style 250 BL as manufactured by *Seton Name Plate Co.* or approved equal. Valve tags shall begin with number one and be numbered consecutively.
- 23.1.26.2 Prepare valve directories showing valve number, location, type of service, equipment controlled and normal position of valve. Frame directories under 1/8" thick clear plastic and mounted as directed by the PM. Separate directory shall be provided for each major mechanical room. Valves located at unit heaters, cabinet heaters, radiation and reheat coils and at other small terminal units where the purpose of the valve is obvious, are not required to be tagged.
- 23.1.26.3 All temperature control switches, gauges, starters, disconnect switches, panels and pilot lights shall be identified with a machine engraved plastic nameplate. Each of the following items shall be identified with a machine engraved plastic nameplate:
  - 23.1.26.3.1 AC units
  - 23.1.26.3.2 Chillers
  - 23.1.26.3.3 Boilers
  - 23.1.26.3.4 Outside air unit
  - 23.1.26.3.5 Ceiling fans
  - 23.1.26.3.6 In-line fans
  - 23.1.26.3.7 All air terminal boxes
  - 23.1.26.3.8 Air sensors
  - 23.1.26.3.9 Unit heaters
  - 23.1.26.3.10 Water heaters

## DIVISION 23 – HEATING VENTILATING AND AIR CONDITIONING

### 23.1.26.3.11 All other similar type equipment

- 23.1.26.4 Letter size on plates for equipment identification shall not be  $< \frac{3}{4}$ " high. Letter size on plates for control panels and small items of equipment shall be  $\frac{1}{4}$ " high. Labels shall be secured in place with screws. Labels shall align with each other and shall be square with lines of surface on which label is placed.  $\frac{3}{4}$ " square ID tags shall be located on metal ceiling grids for equipment above ceilings. Do not provide exposed external labels for equipment located in finished space.
- 23.1.26.5 Roof fans, condensing units and pumps shall be labeled with stenciled letters 1.5" high and painted with a contrasting colored enamel paint.
- 23.1.26.6 Schedule of all labels indicating size, color and lettering shall be submitted for review.

### 23.1.27 Identification of Piping

- 23.1.27.1 Identify all piping installed under this section, except as noted below, by means of plastic pipe markers equal to "Opti-Code" as manufactured by *Seton Name Plate Co., Wilmington Plastics Co.* or approved equivalent stencil. Markers shall be color-coded and shall be lettered in accordance with ANSI specification A13.1. All markers shall be held in place with color-coded tape with flow direction arrows printed on it. Apply a minimum of three (3) complete wraps of tape at each end of pipe markers equal to *Seton Style #AR* or approved equivalent.
- 23.1.27.2 Color coded tape pipe markers with flow arrows shall be applied within 12" of each pipe hanger. Additional markers shall be applied as required to permit reasonable visual identification of each visible pipe line from access doors, shaft openings, removable ceiling panels and other inspection areas. Pipe markers (or stencil) with system name and color coded tape flow arrows shall be located near valves, at points where pipes penetrate walls, floors and ceilings, or at the point where piping enters and exits a vessel, tank or piece of equipment. Pipe markers shall be neatly arranged and applied squarely after pipelines are insulated and/or painted.
- 23.1.27.3 Pipe markers are not required on small equipment connections where identification is obvious.
- 23.1.27.4 Pipe markers shall be installed on exposed piping in finished public spaces.
- 23.1.27.5 Pipe markers are required in fan rooms, mechanical equipment rooms, inside RTUs and above all ceilings.
- 23.1.27.6 The contractor shall submit sample markers and a schedule of lettering and coloring to the architect and to Facilities Management for review.

### 23.1.28 Small-Packaged Heating Water Boilers

- 23.1.28.1 *Harsco P-k N 2000-2* boiler with a *NURO Honeywell Controller*, 2,000,000 BTUH input, 1,700,000 BTUH output. Boiler size may vary depending on location and heating loads, **JMU** has standardized our small packaged unit boilers in an effort to reduce spare parts inventory. The *Patterson Kelly Thermific* boiler with the *NURO Honeywell Controller* is the current preference.
- 23.1.28.2 Contractor shall install an interlocked circulation pump for each boiler that shall be controlled by the boiler controller. Flow 140gpm, Head 18', 1.5 HP. Pumps shall be frame mounted. All pumps shall be mounted and accessible no more than 5' above finished floor.

## DIVISION 23 – HEATING VENTILATING AND AIR CONDITIONING

- 23.1.28.3 Buffer Tank shall be 48" diameter, 500 gallon, ASME 150psig, horizontal tank and base.
- 23.1.28.4 Breeching shall be double walled Metal-Fab Corr/Gard CGDW AL29-4C or JMU approved equal.
- 23.1.28.5 Flue duct shall be single-wall Metal-Fab Corr/Gard CGSW AL29-4C or JMU approved equal.
- 23.1.28.6 Gas regulators shall be *Sensus* service regulator model 243.
- 23.1.28.7 Thermometers shall be digital and solar-powered.
- 23.1.28.8 Pressure gauges shall be 4" spring-dial type, dry, 0-100psi. Pressure gauges shall be installed on localized gauge panel with isolation valve, isolation valve to be equipped with test connection port protruding through front of gauge panel (Dragon Valve 1053V3). Scaling of gauge shall be such that normal operating pressure is at mid scale.
- 23.1.28.9 Condensate drain piping on breeching shall be *Tygon*.
- 23.1.28.10 Pressure reducing stations shall have piping supports on each side of the reducing valve using pipe saddles (for full wrap insulation).
- 23.1.28.11 All pipe guards shall be fabricated by a supplier regularly engaged in the manufacture of these items and installed per manufacturer's installation instructions.
- 23.1.28.12 All relief valve discharges shall be piped to discharge to the floor, and shall incorporate the proper piping supports.
- 23.1.28.13 Anti-seize shall be used for flange bolts only.
- 23.1.28.14 All threaded fittings shall be assembled with suitable pipe joint compound.
- 23.1.28.15 Strainers shall be Y-type with stainless steel mesh or screen baskets for all screwed or flanged applications.
- 23.1.28.16 Air vents shall be used in any system controlled by modulating control valve.
- 23.1.28.17 All modulating boilers shall have a minimum of a 10:1 turn-down ratio.
- 23.1.28.18 All drains from boiler exhaust vent piping and boiler cabinet shall be piped to an appropriate drain, have a trap and be constructed of stainless steel tubing.
- 23.1.28.19 All boiler water discharge piping shall have a check valve installed to prevent reverse flow conditions.
- 23.1.28.20 All boilers shall be installed on appropriate stands or concrete curbing to prevent water damages from floods.
- 23.1.28.21 All pumps shall be installed with properly sized breakers and motor controllers located near the pump that meet NEC requirements.
- 23.1.28.22 All boilers shall have independent outside air intake for boiler combustion to prevent negative room pressures.
- 23.1.28.23 All boiler water supplies shall be fitted with back flow preventers.
- 23.1.28.24 All small-packaged unit boilers with a 1,500,000BTU/H or higher input, shall be equipped with an individual, thermal mass flow type gas meter.
- 23.1.28.25 All gas pressure regulators shall be equipped with mechanical gauges before and after the regulator and shall be scaled to read in "inches water column."
- 23.1.28.26 All heating water systems shall use high performance butterfly valves for isolation, preferred manufacturer is Bray or Velan.
- 23.1.28.27 **Gas Fired Domestic Hot Water Heaters**

## DIVISION 23 – HEATING VENTILATING AND AIR CONDITIONING

- 23.1.28.28 *Harsco* P-k HiDRA boiler HC800 – HC1000 with NURO Control System. Heater size and quantity may vary depending on location and calculated loads. JMU has standardized our small packaged unit gas fired domestic hot water heaters in an effort to reduce spare parts inventory. The *Patterson Kelly HiDRA* domestic hot water heater is the current preference.
- 23.1.28.29 For systems that require dual temp domestic hot water (140 & 120 Loops) the preferred type of mixing valve is an electronic stainless steel mixing valve (Armstrong Brain DRV 40/80).
- 23.1.28.30 RTD's to be installed for monitoring and trending of domestic hot water temperatures to be tied back to building automation system.

### 23.1.29 Fire Dampers

- 23.1.29.1 All fire damper locations shall be identified on the construction drawings as either "floor access" or "above-ceiling access."
- 23.1.29.2 All fire dampers shall be accessible for routine maintenance and inspection.
- 23.1.29.3 A designated JMU representative shall witness the actuation and reset of all fire dampers.

### 23.1.30 Compressed Air (for Labs and Shops)

- 23.1.30.1 Duplex compressor with single tank.
- 23.1.30.2 Refrigerated air drier with piped service bypass.
- 23.1.30.3 Rigid lines shall be copper.
- 23.1.30.4 Pressure regulator valve on main line after pressure tank.
- 23.1.30.5 Auto drain on tank bottom w/shut-off valve and "y"-strainer piped in before drain.
- 23.1.30.6 An "end-of-line" shut-off valve at the point of use.
- 23.1.30.7 Floor-level shut-off valves for overhead hose reels.
- 23.1.30.8 Intake-side air filter at compressor.

### 23.1.31 Kitchen Exhaust Hoods

- 23.1.31.1 Hoods and matching exhaust systems shall be supplied by the same manufacturer.
- 23.1.31.2 Type I hoods designed for collecting and removing grease particulates, condensable vapors, and smoke, shall have an average capture velocity of 70-100fpm, across the entire hood area. VFD fan controls shall be field calibrated to allow this airflow range.
- 23.1.31.3 Type II hood design shall be based on the total BTU output of the equipment it is serving. VFD's shall modulate exhaust fan speed and air volume according to duct temperature.
- 23.1.31.4 Electric gas solenoids used for cooking appliances shall have a manual reset relay (such as a Heiser Logistics model 835 or equivalent) installed so when commercial power to the building is interrupted and then restored the gas solenoid remains in the closed (no gas flow) position until the manual reset relay button is pressed, therefore re-energizing the gas solenoid.

### 23.1.32 Humidification

- 23.1.32.1 See section [23.2.8](#)

## DIVISION 23 – HEATING VENTILATING AND AIR CONDITIONING

### (23.2) STEAM

#### 23.2.1 General

- 23.2.1.1 The contractor shall provide all material, equipment and steam system connections required to provide JMU with the safest steam system possible.
- 23.2.1.2 Steam is available to the campus year-round and provided at pressures of 100, 150 and 250psig. Campus steam heat shall be utilized whenever possible. The campus steam distribution system pressure varies depending on location. When the connection point is determined, the system shall need to be designed based on that supply pressure.
- 23.2.1.3 Condensate generated by the steam use on campus shall be returned to the Power Plant by gravity return system or a pump system.
- 23.2.1.4 All valves, fittings, pipe and flanges shall be designed to only carry pressures of 150 or 300 psig, depending on location and shall be clarified during design. **Components with ratings of 125 and 250 psig rated are NOT ALLOWED at any location.**
- 23.2.1.5 All steam piping shall be schedule 40 ASTM Type “A” 106 seamless black steel pipe.
- 23.2.1.6 All condensate piping shall be schedule 80 ASTM Type “A” seamless black steel pipe.
- 23.2.1.7 All condensate return systems shall use an open loop configuration. Condensate coolers are not permitted.
- 23.2.1.8 All steam and condensate pipe 2 ½” and larger shall be welded.
- 23.2.1.9 All steam and condensate piping 2” and smaller shall be threaded.
- 23.2.1.10 All traps to be installed with unions and isolation valves for ease of removal. Traps to be installed with y-strainer, test tees and check valves. The components, from drip leg to condensate return, shall be located in the following order:
  - 23.2.1.10.1 800 PSI carbon steel isolation valve
  - 23.2.1.10.2 Y-strainer
  - 23.2.1.10.3 Union
  - 23.2.1.10.4 Trap
  - 23.2.1.10.5 Union
  - 23.2.1.10.6 Tee with 3/8” or ¼” NPT test port valve.
  - 23.2.1.10.7 Check valve
  - 23.2.1.10.8 800 PSI carbon steel isolation valve
  - 23.2.1.10.9 Piping to the trap shall be (schedule 40)
  - 23.2.1.10.10 Piping from the trap shall be (schedule 80)
- 23.2.1.11 Steam traps have been standardized campus wide and Armstrong steam traps are the preferred manufacturer. If another equivalent manufacturer is selected, the contractor shall provide the university with 7 traps of the same model to be used as spares.
- 23.2.1.12 Pressure reducing stations shall have support piping on each side of the reducing valve using pipe saddles for full wrap insulation. Steam pressure reducing valves shall also be equipped with flanges or UNIFLEX couplings to allow for removal. Standard unions are not acceptable. Pressure reducing valves that require external sensing lines shall use stainless steel sensing lines. Each pressure reducing station shall also be equipped with mechanical gauges on the inlet and outlet sides as well as pressure

## DIVISION 23 – HEATING VENTILATING AND AIR CONDITIONING

transmitters to be connected back to building automation system for remote monitoring and trending.

- 23.2.1.13 All pipe guards shall be fabricated by a supplier regularly engaged in the manufacture of these items and installed per manufacturer's installation instructions.
- 23.2.1.14 Any piping penetrations through tunnel walls, lids or building foundations shall be sleeved and sealed with a mechanical seal. Seal shall be expandable and water tight. Seal shall be sealed on the exterior with water tight, non-shrink grout.
- 23.2.1.15 Air vent relief discharges shall be piped to discharge to the floor.
- 23.2.1.16 Anti-seize compound shall be used for flange bolts only.
- 23.2.1.17 Flange nuts and bolts shall be ASTM A193/A193M, grade "B7" plain bolts with ASTM A194/A194M grade "2H" plain nuts. Zinc plated or galvanized steel bolts and nuts are not permitted on *any* steam or condensate application.
- 23.2.1.18 Steam regulators shall accommodate minimum and maximum steam loads. Pressure reducing steam stations shall be configured for parallel operation with two separate pressure reducing valves. If pressure reduction is more than a 10:1 ratio, then the station shall be configured for two-stage reduction. All pressure reducing stations shall be equipped for remote monitoring by the use of pressure transmitters on the HP and LP legs of the PRV. They shall also be equipped with mechanical gauges. Spence pressure reducing valves are the preference.
- 23.2.1.19 Underground steam and condensate lines shall be installed in accessible tunnels and vaults, or with a direct-buried, pre-insulated, non-asbestos piping system. Tunnels and vaults shall have pumps installed when surface water is a problem. Vaults shall also be sloped to allow water to run to sump hole. For direct buried pre-insulated piping systems Perma-Pipe is the preferred manufacturer, these systems shall be equipped with 304/316 SS end seal assemblies and shall use aerogel insulation on carrier pipe.

### 23.2.2 Condensate Pumps

- 23.2.2.1 Shall be sized to accommodate the steam system. Install pump plumb and level. Each pump and receiver shall be an ASME 150 rated vessel. Receivers shall be vented to the atmosphere. Each pump shall have an isolation valve on the condensate inlet and outlet, a check valve on the condensate inlet and outlet and be individually drainable. Each pump/receiver shall have its own sight glass to determine level, and its own pressure gauge to determine discharge pressure.
- 23.2.2.2 Pressure powered pumps are the preferred pumping method using steam supply as the prime motive. The pressure powered pump shall be equipped with its own pressure regulator for the steam supply with a 100 mesh y-strainer and a cycle counter. Each pump shall have a removable and reusable insulation blanket.
- 23.2.2.3 Centrifugal pumps are optional depending on the location, but shall be sized appropriately and shall be rated for high temperature applications of up to 210°F.
- 23.2.2.4 Traps shall be sized and installed for proper application of drip legs, mechanical equipment and radiators. Inverted bucket traps shall be used on drip legs and F&T traps shall be used on process heaters, converters and heat exchangers. Steam traps have been standardized campus wide and Armstrong steam traps are the preferred

## DIVISION 23 – HEATING VENTILATING AND AIR CONDITIONING

manufacturer. If another equivalent manufacturer is selected, the contractor shall provide the university with 7 traps of the same model to be used as spares.

- 23.2.2.5 Strainers shall be Y-type with stainless steel 100 mesh or screen. All Y-strainers shall be rolled 90° for steam line applications to prevent condensate collection. Strainers shall also be equipped with blow-down valves.
- 23.2.2.6 Air vents shall be used in any system controlled by a modulating control valve.
- 23.2.2.7 All steam pipes shall be insulated to a minimum value of R-8.
- 23.2.2.8 Insulation blankets shall be removable/reusable two piece insulation blankets to cover pressure-powered condensate pumps, pressure regulators, steam traps valves and expansion joint body. Steam Traps shall not be insulated.
- 23.2.2.9 Gauges shall be 4" dry gauge with ¼" MPT connection and shall range so normal operating pressure is at mid-scale. . Gauge shall be supplied with an anti-siphon tube / pigtail and an isolation valve. Petcock type valves are not permitted.

### 23.2.3 Gaskets

- 23.2.3.1 Steam systems shall use Type 304/316 stainless steel spiral-wound gaskets with non-asbestos fillers and stainless steel outer rings.
- 23.2.3.2 Condensate systems shall use full-faced 83arlock or spiral-wound gaskets all for flanged applications.
- 23.2.3.3 Expansion joints shall *only* be slip or ball type. They shall be designed for (150/300psig) @ 500°F for steam or condensate service.
- 23.2.3.4 Instantaneous or semi-instantaneous water heaters shall be pre-piped with only necessary steam, water and condensate hookups. Instantaneous/semi-instantaneous water heaters shall operate on water differential using the feed-forward principle. All water heaters shall be equipped for remote monitoring via BAS to include domestic hot water temperature supply and return temperature on recirculating loop. .

### 23.2.4 Heating Water Converters

- 23.2.4.1 Tube and shell design shall use water in the tubes and steam in the jacket. Straight tube design is preferred, but the U-tube design is acceptable.
- 23.2.4.2 Heating water converters shall also have 1.5" NPT branch connections on the inlet and outlet side of the heating water loop to allow for inspection and cleaning of the converter. The converter shall also be equipped with local thermometers and pressure gauges on the water piping side of the converter.

### 23.2.5 Steam/Condensate Flow Meters

- 23.2.5.1 Steam meters shall be of the "vortex-shedding" type and shall have pressure or temperature compensation capabilities to adjust for pressure and/or temperature fluctuations. Each meter shall have a flow totalizer/computer to show current flow rate, as well as totalized flow rate. These devices shall be interconnected with the B.A.S. being used. The accuracy of the flow meter shall be within +/-1.0% of the actual flow rate. The flow rate shall be measured and displayed in lbs/hr and totalized in klbs.
- 23.2.5.2 Condensate flow meters shall be of the electromagnetic flow meter type. Each meter shall have a flow totalizer computer to show current flow rate and totalized flow rate. These devices shall be interconnected with the B.A.S. being used. The accuracy of the

## DIVISION 23 – HEATING VENTILATING AND AIR CONDITIONING

flow meter shall be within +/-1.0% of the actual flow rate. The flow rate shall be measured and displayed in lbs/hr and totalized in klbs.

### 23.2.6 Control Valves

**23.2.6.1** Control valves that are used on steam applications shall be rated for high temperature applications and of the electronic or pneumatic type. The pneumatic tubing for the control valve shall be copper or stainless steel. Plastic tubing is not allowed within 3' of the control valve. All control valves shall be rolled so that actuator is not directly above steam line.

**23.2.6.2** All control valves shall have isolation valves both before and after the control valve, as well as a y-type strainer before the control valve. The control valve shall also have a globe type bypass valve.

### 23.2.7 Underground Piping

**23.2.7.1** All underground piping systems shall be direct-buried, pre-insulated piping. The water tight integrity of these systems is critical and all possible measures shall be taken to ensure water tight integrity. End seals shall be fabricated of stainless steel materials.

**23.2.7.2** All test procedures shall be followed and witnessed by a JMU representative.

### 23.2.8 Humidification

**23.2.8.1** Direct-injection humidifiers are not permitted.

**23.2.8.2** In-Direct humidifiers (Steam Heat Exchanger Humidifiers) are permitted when the air quality requirements dictate. When using indirect injection humidifiers, the water shall be pre-treated to remove impurities. Water softeners shall be installed to pre-treat the water prior to flowing into the humidifier. Deionized, demineralized or reverse osmosis water systems are other approved options for water pre-treatment.

### 23.2.9 Safety Relief Valves

**23.2.9.1** Safety relief valves shall be installed on pressure reducing stations and elsewhere as required by the current ASME Boiler and Pressure Vessel Code.

**23.2.9.2** Install safety valve discharge piping, without valves, to be vented to the atmosphere. If interior pipe chase is used for routing of discharge, the chase shall be vented and the escape piping shall also be insulated. Do not insulate the safety relief valve. Tell-Tale drains or drain holes on the valve body shall be routed to the closest floor drain. The lifting test level shall be clear of any obstructions to allow for routine testing.

**23.2.9.3** Safety valve discharge piping shall be piped independently of any other vent or escape piping

### 23.2.10 Isolation Valves For Steam & Condensate Systems

**23.2.10.1** Gate valves are the *only* permitted isolation valves for steam and condensate systems.

**23.2.10.2** Globe valves are the *only* permitted valves used for throttling applications; i.e. bypass.

**23.2.10.3** Cast Iron Valves, ball valves or butterfly valves are not permitted on steam applications unless authorized by a JMU representative.

## DIVISION 25 – BUILDING AUTOMATION SYSTEMS

### (25.1) BUILDING AUTOMATION SYSTEMS (B.A.S.)

#### 25.1.1 General

- 25.1.1.1 The intent of this specification is to establish the minimum acceptable standards of execution on all projects that impact the JMU Building Automation System. These standards exist to protect the integrity of the existing Building Automation System, ensuring its reliability and performance in support of the overall mission of JMU. These standards shall apply to both Facilities Planning and Construction (Capital Outlay) projects and Facilities Management Engineering Projects.
- 25.1.1.2 *Automated Logic Corporation* and *Siemens Building Technologies* are the pre-approved BAS vendors and shall provide a bid package to the following JMU BAS representative:

Matthew Jefferson  
Facilities Management Building  
MSC 7007 Harrisonburg Va. 22807  
Phone – (540) 568-4303

- 25.1.1.3 Internet access to the JMU BAS network is strictly limited to JMU employees. No contractors, commissioning agents or anyone else shall be given access at any time or for any reason.
- 25.1.1.4 The same BAS manufacturer shall be used throughout a particular building. JMU BAS reserves the right to waive this requirement at their sole discretion.
- 25.1.1.5 The BAS shall not be used for smoke control applications (UL 864 UUKL Compliance).
- 25.1.1.6 The BAS shall not be used for control of lighting systems.

#### 25.1.2 BAS Bid Process

- 25.1.2.1 The two pre-approved BAS vendors shall submit proposals detailing their Scope of Work to the JMU Mechanical Trades Manager and the JMU BAS Supervisor no less than ten (10) business days prior to the day bids are due. JMU BAS shall review and evaluate the proposals to ensure compliance with both the project specifications and the JMU Design and Construction Guidelines. JMU BAS shall have the opportunity to make comments on each proposal and request changes before bids are submitted. JMU BAS shall approve each proposal prior to bid submission. The BAS contractor shall provide the following information in their proposal:
- 25.1.2.1.1 An itemized Scope of Work detailing each major mechanical system to be controlled and the proposed controller(s) for each system.
- 25.1.2.1.2 A total number of zones to be controlled itemized by zone type (VAV, Fan Coil Unit, etc.) and the proposed controllers for each zone type.
- 25.1.2.1.3 An itemized breakout of any additional miscellaneous systems to be controlled and/or monitored in order to meet the project specifications.
- 25.1.2.1.4 Descriptions of any major additions to the BAS Servers or Operator Work Stations.
- 25.1.2.1.5 The cost of any required software or point count licenses.
- 25.1.2.1.6 A \$5000 allowance for networking equipment on projects with a contract value of \$100,000.00 or more and a \$2500 allowance on projects with a contract value less than \$100,000.00.

## DIVISION 25 – BUILDING AUTOMATION SYSTEMS

- 25.1.2.1.7 An allowance of \$1000 per each mechanical room containing a major mechanical system for thin-client workstations.
- 25.1.2.1.8 A total quote of the project with a written statement of any exceptions taken.
- 25.1.2.2 The BAS contractor shall provide all Variable Frequency Drives above 1 horsepower. The cost for these drives shall be included in the BAS contractor's bid price. Any excluded Variable Frequency Drives shall be explicitly noted in the proposal.
- 25.1.2.3 The BAS contractor shall provide \$5,000 in training funds on all projects with a contract value of \$100,000.00 or more. On contracts less than \$100,000.00, no training funding shall be required. JMU shall utilize these funds at their discretion to provide training in HVAC, Automation and Energy related fields.
- 25.1.2.4 JMU shall be considered a preferred customer with or without a maintenance agreement with the contractor.

### 25.1.3 Qualified Bidders

- 25.1.3.1 The following are the only approved manufacturers of BAS equipment. No other manufacturers shall be qualified to bid.
  - 25.1.3.1.1 *Automated Logic Corporation*, as installed by the *Automated Logic Corporation – Virginia* branch office located in Richmond, VA.
  - 25.1.3.1.2 *Siemens Building Technologies*, as installed by the *Siemens Building Technologies* branch office located in Richmond, VA.

### 25.1.4 Quality Assurance & Guarantee of Work

- 25.1.4.1 Materials shall be the best of their respective kinds. All materials shall be new. Work provided by the BAS contractor for each section of this specification shall be constructed and finished in every part in a substantial and workmanlike manner. Items necessary for the completion of the work and the successful operation of a product shall be provided even though not fully specified or indicated in each section.
- 25.1.4.2 Materials furnished under this section shall be standard cataloged products of recognized manufacturers regularly engaged in the production of such material and shall be the latest design.
- 25.1.4.3 Upon completion of the installation, the BAS contractor shall verify by demonstration to the owner that the system is fully functional, installed in accordance with the plans and specifications and calibrated to operational limits specified. Acceptable documentation and test procedures shall be as approved on the initial project submittals. The BAS contractor and JMU Building Automation personnel shall perform a complete point to point checkout to verify proper installation and operation, to include all control processes.
- 25.1.4.4 The BAS contractor shall guarantee the system to be free of defects in workmanship and/or material for a period of one (1) year from the date of acceptance. The system shall not be accepted until the completion of any commissioning, the point to point checkout by JMU Building Automation personnel, graphics completion, and the delivery of the As-Built drawings. All deficiencies shall be corrected in a timely manner and without additional expense to JMU.
- 25.1.4.5 The BAS contractor shall provide the JMU Building Automation supervisor with a Warranty Letter stating the date the warranty begins.

## DIVISION 25 – BUILDING AUTOMATION SYSTEMS

**25.1.4.6** JMU reserves the right to make changes to the BAS during the warranty period. Such Changes do not constitute a waiver of warranty. The BAS contractor shall warrant parts and installation work regardless of any such changes made by JMU, unless the BAS contractor provides clear and indisputable evidence that a specific problem is the result of such changes to the BAS. Any disagreement between JMU and the BAS contractor on such matters shall be subject to resolution through the contract 'Disputes' clause.

### 25.1.5 Submittals & As-Built Drawings

- 25.1.5.1** Provide complete shop drawings, catalog data sheets, schematics and other data necessary to fully describe and substantiate compliance with these specifications for all control items and systems included or connected as part of this system. On-site work shall not begin until submittals have been approved by the Engineer and JMU.
- 25.1.5.2** The exact location for all control devices located outside of mechanical rooms such as down duct static sensors, space static sensors and floor return dampers shall be noted on the final drawings.
- 25.1.5.3** The BAS contractor shall provide As-Built drawings, sequences of operation, graphics and control processes in electronic format in addition to (1) 11"x17" hard copy.
- 25.1.5.4** Provide two (2) copies of Operation & Maintenance manuals. Manuals shall include required maintenance procedures for each system provided and a list of recommended spare parts.
- 25.1.5.5** As part of the As-Built drawing package, the BAS contractor shall provide a network diagram showing the path of all Ethernet and RS-485 cabling. This diagram shall be superimposed over a building floor plan and note the location of all network devices.
- 25.1.5.6** The BAS contractor shall provide written documentation of all setup values for each utility meter installed, to include electric meters, steam meters, and water meters and any associated devices such as flow calculation computers, etc.

### 25.1.6 Project Execution

#### 25.1.6.1 General

- 25.1.6.1.1** The BAS contractor shall provide material and labor to perform start-up of each piece of equipment or system prior to the beginning of test, adjust and balance procedures.
- 25.1.6.1.2** The BAS contractor shall provide all information and assistance necessary to support commissioning and balancing.
- 25.1.6.1.3** The BAS contractor shall provide periodic adjustment as necessary to ensure proper operation of the mechanical systems after occupancy until the system is accepted.
- 25.1.6.1.4** The BAS Contractor shall provide a construction server that includes the necessary server hardware and software licensing for the successful completion of the project. Remote access to the construction server shall be the sole responsibility of the BAS contractor. The BAS contractor shall not connect any new projects to the JMU BAS network before project completion or before the completion of commissioning. JMU BAS authorization prior to connection is required. The BAS Contractor shall be responsible for migrating the database from the construction server to the JMU BAS production server.
- 25.1.6.1.5** The BAS contractor shall be responsible for all necessary revisions and upgrades to all software on the production server as required to seamlessly

## DIVISION 25 – BUILDING AUTOMATION SYSTEMS

integrate the new project into the existing BAS and provide a complete and workable system consistent with the letter and intent of the specification. Final installed software shall be of the manufacturer's latest available release.

### 25.1.6.2 BAS System Design Requirements

- 25.1.6.2.1 All air handling equipment shall be directly controlled by the BAS. Third-party or factory controls are not permitted.
- 25.1.6.2.2 Where possible, chillers shall control the primary chilled water pump, the cooling tower bypass valve, and cooling tower fan speed. The BAS shall have the capability to command these devices for maintenance.
- 25.1.6.2.3 All RS485 communication trunks shall have at least 10% spare capacity for adding controllers to the trunk in the future.
- 25.1.6.2.4 Modular-type controllers with expandable input and output capabilities are preferred over controllers with fixed point counts. The use of fixed point count controllers shall be approved in writing by JMU BAS.
- 25.1.6.2.5 Primary equipment such as AHUs and hydronic systems shall be controlled using one controller with sufficient inputs and outputs to control the system. The use of several smaller controllers in lieu of one larger controller is prohibited.

### 25.1.6.3 Coordination with Other Contractors

- 25.1.6.3.1 The BAS contractor shall coordinate the installation of all control devices and shall verify supporting work by others such as sensor wells, pressure taps, orifice plates, access panels, electric power supplies and all other related items required to support proper BAS installation, operation and maintenance.
- 25.1.6.3.2 All valves, immersion wells and flow meters, including domestic water meters, for the BAS shall be furnished by the BAS contractor for installation by the mechanical contractor.
- 25.1.6.3.3 All 120V and higher power shall be provided by the project electrical contractor. The BAS contractor shall coordinate their specific power needs with the project electrical contractor.

### 25.1.6.4 Networking/Communications

- 25.1.6.4.1 BACnet/IP is the required protocol for all tiers of the network. *Siemens* P1 and P2 protocols may be used in certain cases when approved in writing.
- 25.1.6.4.2 The BAS WAN or Wide Area Network shall be defined as the secured, dedicated IP network connecting campus buildings to the JMU BAS office. This network is physically separate from the JMU Campus Network.
- 25.1.6.4.3 The BAS LAN or Local Area Network shall be defined as the dedicated IP network connecting Management Level Devices and thin-client workstations within a particular building. This network shall utilize CAT-6 cabling in lieu of fiber optic cable whenever possible. This network is physically separate from the JMU Campus Network.
- 25.1.6.4.4 The BAS FLN or Floor Level Network shall be defined as the dedicated BACnet/IP network connecting Floor Level Devices to BACnet routers. The BAS FLN shall utilize a ring topology with Spanning Tree Protocol or Rapid Spanning Tree Protocol enabled in accordance with industry best practices.

## DIVISION 25 – BUILDING AUTOMATION SYSTEMS

- 25.1.6.4.5** Each floor shall have a minimum of one BACnet router to route BACnet/IP traffic between the BAS FLN and the BAS LAN.
- 25.1.6.4.6** The design of the hardware and software shall network existing operator workstations at the JMU BAS office with new Management Level Devices on the BAS LAN via the BAS WAN.
- 25.1.6.4.7** The BAS contractor shall receive pre-approval for all network hardware locations from JMU BAS prior to installation.
- 25.1.6.4.8** All Ethernet switches, SFP transceivers, and fiber optic patch cables shall be selected by JMU BAS, provided by the BAS contractor, and paid for out of the networking allowance. Ethernet switches shall be delivered to JMU BAS for configuration.
- 25.1.6.4.9** The BAS contractor shall provide a BAS WAN Ethernet switch for installation in the telecom MDF room.
- 25.1.6.4.10** The BAS contractor shall provide a minimum of one Ethernet switch connected to the BAS LAN in each mechanical room. In the case of controllers mounted in rooftop air handling units, the BAS contractor shall provide an Ethernet switch at each rooftop unit and they shall be connected to the BAS LAN with CAT-6 cable.
- 25.1.6.4.11** The BAS contractor shall provide any additional Ethernet switches as necessary to provide a functional and stable network.
- 25.1.6.4.12** BAS LAN Ethernet cabling shall be plenum-rated CAT-6 cabling. All Ethernet cabling shall have a pink colored jacket.
- 25.1.6.4.13** Wherever practicable, building Ethernet cabling shall be run directly to the telecom MDF room (home run). If the cabling distance exceeds the maximum distance rating for CAT-6, it shall be run to the nearest telecom IDF room and converted to fiber optic cable, subsequently terminating in the telecom MDF room. The BAS contractor shall coordinate any such fiber path with JMU Telecom. The use of Ethernet range extenders for copper cabling is unacceptable.
- 25.1.6.4.14** All IP addresses, BACnet instance numbers, BACnet network numbers, and other network parameters shall be coordinated with and approved by JMU BAS prior to implementation.

## DIVISION 25 – BUILDING AUTOMATION SYSTEMS

### 25.1.6.5 BAS Interfacing with Third-Party Subsystems

- 25.1.6.5.1 The BAS contractor shall be responsible for connecting all sub-systems to the BAS via native BACnet interfaces (provided by the equipment OEM), or if not native BACnet, a sub-system shall be integrated via a gateway that converts the proprietary protocol to BACnet. Sub-systems include, but are not limited to, chillers, boilers, domestic water heaters, and variable frequency drives.
- 25.1.6.5.2 Variable frequency drives shall have hard-wired start/stop, status, and speed control points. BACnet/IP integration to variable frequency drives is required and shall be used for monitoring purposes only.
- 25.1.6.5.3 Chillers shall have hard-wired start/stop, running status, and alarm status points. A BACnet/IP interface to chillers is required and shall be used for monitoring purposes only.
- 25.1.6.5.4 Boilers shall have hard-wired start/stop and alarm status points. A BACnet/IP interface to boilers is required and shall be used for monitoring purposes only.
- 25.1.6.5.5 If a sub-system does not include a native BACnet/IP interface, the BAS contractor shall provide a *Contemporary Controls BASgatewayLX* or other gateway approved in writing by JMU BAS. The BAS contractor shall be responsible for the configuration of any and all gateways.

### 25.1.6.6 BAS Operator Interface Requirements

- 25.1.6.6.1 The BAS contractor shall provide a color graphic for each mechanical system and a floor plan graphic for each floor. All information shall be displayed in real time dynamic fashion. All new graphics shall be similar in style to the existing system graphics and shall be pre-approved by the JMU BAS supervisor.
- 25.1.6.6.2 Each VAV, CAV or similar type equipment point names shall include the associated AHU number.
- 25.1.6.6.3 Each AHU, RTU or similar type equipment graphic shall have a detailed description of all areas served, the type of associated equipment as well as the physical location of the unit; e.g., AHU #1 serves 1<sup>st</sup> and 2<sup>nd</sup> floor VAV system, and is located in the main mechanical room in the basement.
- 25.1.6.6.4 All lead, lag, and standby controls, including chillers, pumps and boilers, shall be able to be switched by changing the state of a single point mapped to the head end.
- 25.1.6.6.5 Programming style should be consistent with existing JMU programs. The best programs are the most simplistic while still being able to provide the control needed.

### 25.1.6.7 Field Installation Requirements

- 25.1.6.7.1 All wiring, regardless of voltage, required for proper installation and operation of the BAS components shall be furnished and installed by the BAS contractor.
- 25.1.6.7.2 All wiring in mechanical and electrical equipment rooms or other areas where exposed shall be installed in EMT or similar type conduit. Blue colored conduit is preferred. Wiring exposed in occupied areas shall be installed in wire mold.

## DIVISION 25 – BUILDING AUTOMATION SYSTEMS

- 25.1.6.7.3 All wiring shall be labeled at both ends with machine-printed labels. Labels shall specify the system name of the connected device as well as the point address.
- 25.1.6.7.4 The location of all Floor Level Network controllers, down duct static sensors, and other control devices located above the ceiling shall be labeled on the ceiling grid with machine-printed labels.
- 25.1.6.7.5 All controllers shall be mounted in suitable enclosures that are environmentally maintained within the identified temperature, humidity, and vibration limits of the particular controller.
- 25.1.6.7.6 Control panels shall be equipped with a minimum of (2) 120VAC convenience outlets.
- 25.1.6.7.7 All BAS panels shall be mounted in the same room as the equipment being controlled.
- 25.1.6.7.8 Mounting of BAS control panels in locations where access requires exposure to the weather (i.e. on the side of rooftop units) is unacceptable. Controls for rooftop units shall be mounted in sheltered locations to protect the controls and the service technicians from the elements.
- 25.1.6.7.9 Each control panel shall have a packaged power supply. Acceptable products are *Function Devices* PSH series or *Siemens* PXA Service Boxes.
- 25.1.6.7.10 All line voltage wiring within control panels shall be protected behind covers and/or in raceways. Exposed line voltage circuitry is prohibited.
- 25.1.6.7.11 Control wiring within control panels shall be neatly routed and terminated without excessive cable length. Where ever possible, control wiring should be concealed by wire duct. Control wiring shall run straight into each control panel and shall not be routed through another control panel.
- 25.1.6.7.12 Control relays mounted in control panels shall be DIN-Rail mounted and provided with a visual status indicator.
- 25.1.6.7.13 All controllers or transformers powering BAS controllers shall be energized by a dedicated, suitably sized, circuit breaker energizing no other equipment.
- 25.1.6.7.14 Floor Level Network (FLN) devices such as VAV or FCU controllers shall be powered by *Functional Devices* PSH500A or equivalent transformers. These transformers shall be mounted as close as possible to the FLN management device. All circuits shall be labeled with the devices powered by that circuit.
- 25.1.6.7.15 All controllers, including Floor Level Network controllers, shall be labeled using machine-printed labels that correspond to the device name in the system database.
- 25.1.6.7.16 All equipment safeties such as freeze stats, fire stats, smoke detectors, etc. shall be hard wired to stop their respective equipment and return all controlled devices to their normal position.
- 25.1.6.7.17 All relays, CTs, E-Ps, P-Es and other safety devices that require a manual reset shall be installed in readily accessible locations. All relays shall have LED indicators and should be mounted in viewable locations.
- 25.1.6.7.18 The BAS contractor shall remove all existing controls and associated wiring or tubing no longer needed. Abandoning in place is not acceptable.
- 25.1.6.7.19 The BAS contractor shall provide full-feature space temperature sensors in private and semi-private spaces. These sensors shall include a display of the

## DIVISION 25 – BUILDING AUTOMATION SYSTEMS

room temperature as well as buttons for temporary occupancy override and room temperature setpoint adjustment.

**25.1.6.7.20** Public spaces such as hallways, atriums, and lounges shall have blank space temperature sensors.

**25.1.6.7.21** The BAS contractor shall provide, install, and configure all required refrigerant monitors. All strobes associated with the refrigerant monitor shall be amber in color. Refrigerant monitors shall be connected to the JMU automation system.

### 25.1.7 Approved Hardware

**25.1.7.1** BACnet FLN Routers: *Automated Logic G5CE, Siemens PXC00-E96.A.*

**25.1.7.2** Primary Mechanical System Controllers: *Automated Logic OF-1628/OF-1628-NR controllers, Siemens PXC100-PE96.A, Siemens PXC100-E96.A, Siemens PXC36 Compact Series.*

**25.1.7.3** Zone Controllers: *Automated Logic Optiflex controllers, Siemens DXR2 BACnet/IP controllers.*

**25.1.7.4** All main and ancillary BAS hardware components shall be manufactured by *Automated Logic Corporation or Siemens Building Technologies.*

**25.1.7.5** All laboratory controls (supply and exhaust valve controllers, room pressure controls, fume hood controls, etc.) shall be manufactured by *Automated Logic Corporation or Siemens Building Technologies.* Exceptions must be approved in writing by JMU BAS.

**25.1.7.6** All actuators shall be electronic and manufactured by *Belimo or Siemens.*

**25.1.7.7** All control valves shall be manufactured by *Belimo or Siemens.*

**25.1.7.8** All other components not made by *Belimo, Automated Logic Corporation, or Siemens,* shall be pre-approved by JMU BAS.

**25.1.7.9** All variable frequency drives (VFDs) greater than one horsepower shall be *Danfoss FC102* drives with BACnet/IP communication. *Trane* VFDs that are rebranded *Danfoss* drives are not approved.

**25.1.7.10** All domestic water meters shall be *Toshiba LF654* electromagnetic meters or *Flexim* ultrasonic meters selected by JMU BAS and provided by the BAS contractor.

**25.1.7.11** All required hot water and chilled water flow meters shall be *Toshiba LF654* electromagnetic meters or *Flexim* ultrasonic meters selected by JMU BAS and provided by the BAS Contractor.

**25.1.7.12** All electric meters and sub-meters shall be Square D model PM5560.

**25.1.7.13** All current sensing relays shall be split-core *Hawkeye* brand.

**25.1.7.14** All refrigerant monitors shall be *Bacharach* brand.

### 25.1.8 Utility Metering

**25.1.8.1** The BAS contractor shall be responsible for installation of all piping, valves, and labor necessary to install utility meters as specified unless the mechanical contractor is specified. The BAS contractor shall coordinate.

**25.1.8.2** The BAS contractor shall provide a steam meter on any project utilizing the campus steam system. The project mechanical contractor shall be responsible for the installation and setup of the meter and any additional parts needed to complete the installation. Steam meter components shall be pre-approved by the JMU Power Plant manager.

## DIVISION 25 – BUILDING AUTOMATION SYSTEMS

- 25.1.8.3** All meters shall be networked with the *JMU WebCTRL* system and provide real-time readings. The automation contractor shall provide all necessary conduit, cabling, and network equipment.
- 25.1.8.4** Meters shall be insulated at each building on each utility and shall be capable of showing cumulative energy demand and of measuring the maximum and minimum anticipated flow rates.
- 25.1.8.5** The BAS Contractor shall provide written documentation of all set up parameters for electric, steam/water meters, flow calculators and other similar metering devices.

### (26.1) ELECTRICAL

#### 26.1.1 General

- 26.1.1.1 The campus' primary electrical system is 23 K.V. and owned by the Harrisonburg Electrical Commission (HEC). Secondary services to buildings and facilities shall be 480/277V or 208/120V. Both systems shall be 3-phase, 4-wire WYE connected. All buildings shall be provided with a shunt trip main circuit breaker.
- 26.1.1.2 HEC shall provide and install transformers and make primary and secondary connections. The contractor shall provide transformer pad and HEC shall provide pad specifications and inspections. For further information contact the HEC via Mr. Zach Nyce; P.E., (540) 434-4361.
- 26.1.1.3 All damages incurred to new or existing electrical installations shall be immediately reported to the PM and repaired by the contractor at no additional cost to JMU.
- 26.1.1.4 The A/E or contractor shall provide two (2) copies of all operating manuals, diagnostic tools, software and sufficient training for all electrical systems and their components; e.g. generators, FAC system, lighting controls, etc.
- 26.1.1.5 A/E shall verify current NEC at design phase.
- 26.1.1.6 The main electrical room shall have direct exterior and interior access and be separate from any mechanical room.
- 26.1.1.7 Ceilings are not allowed in Mechanical/Electrical/Telecom rooms.
- 26.1.1.8 Use only standard type toggle switches to operate the lights in all electrical, mechanical and telecommunication rooms. The use of motion type sensors is not acceptable.
- 26.1.1.9 An Arc Flash Study shall be required and all electrical panels shall be labeled per NFPA 70e. A short circuit and coordination study shall be performed in all new building electrical systems. This should be done to ensure the proper overcurrent device will open due to a short circuit.
- 26.1.1.10 It is the responsibility of the Architect/Engineer to design a life safety electrical distribution system that does not require equipment resizing to meet the requirements of NEC selective coordination.
- 26.1.1.11 All separate variable speed drives and combination starters shall be provided by the mechanical contractor.

#### 26.1.2 Inspections

- 26.1.2.1 All electrical work shall be inspected and approved by the JMU electrical inspector. Inspections shall be scheduled by the contractor and additional inspections shall occur at the discretion of JMU.
- 26.1.2.2 Job-site construction drawings shall show actual conduit runs. They shall be marked and maintained on a daily basis throughout the entire project.
- 26.1.2.3 Upon project completion "as-built" drawings shall be submitted showing the actual finished locations of all electrical systems and any modifications to the original approved drawings.

#### 26.1.3 Service

- 26.1.3.1 All breakers shall be a minimum of 20A rated.

- 26.1.3.2** Every electrical panel board shall be rated at 225-amp minimum. The MCB and all conductors shall be sized to full panel board capacity. Sizing of conductors and MCB's shall not be based on load calculation only. Each panel board shall have its own 225A circuit from the Main Switchgear or MDP. Main lug or "Pass-Through" lug panels are not allowed, unless pre-approved for life safety reasons only. Refer to section [25.8.1](#) for sizing Life Safety panels.
- 26.1.3.3** Electrical panels shall have 40% spare capacity. Supply a minimum of eight (8) ¾" empty conduits from recessed panels to an accessible location for future use.
- 26.1.3.4** No panel boards shall be located in housekeeping closets. Provide electrical closets on each floor dedicated to electrical panels only.
- 26.1.3.5** Kitchens shall have dedicated electric panelboard(s) serving only kitchen-related outlets. Feeding kitchen-related circuits from other electrical panelboards is unacceptable. Kitchen related panelboards shall have a minimum of (8) spare ¾" conduits and two (2) 1" conduits stubbed into acceptable ceiling space for future kitchen-related circuits. Any kitchen equipment 208 volt, single or three-phase, shall be hard wired using flexible liquid-tight conduit. Disconnecting means are to be provided if panels are not in sight of said equipment.
- 26.1.3.6** All interior transformers shall be floor mounted.
- 26.1.3.7** Integrated transformer/panel boards shall not be used.
- 26.1.3.8** Switchboards, panelboards and components shall have copper buss bars.
- 26.1.3.9** Main switchboards shall contain a 10-function electronic digital monitoring system. This monitor shall have capabilities to reset approximate values, KWH in particular.
- 26.1.3.10** When panel boards are used as main service equipment, the same meter shall be installed adjacent to it and provisions for current transformers and other connections shall be made.
- 26.1.3.11** Provide written documentation of all parameters for digital electrical meters provided in the switchgear.
- 26.1.3.12** Fusible switches shall be spring-loaded types, with interlock and padlock capabilities.
- 26.1.3.13** Provide spare fuses for fusible switches. Fuses shall be stored in the main electrical room.
- 26.1.3.14** All switchgears shall have bake-lite nameplates.
- 26.1.3.15** Panel boards for light and power shall be of the dead-front, automatic C/B type. Circuit breakers shall be bolt-on or I-line type. Panel boards shall have copper grounding bars. Covers shall be sided hinged.
- 26.1.3.16** When an electrical panel is surface mounted, all under slab conduit that turns up into the electrical panel, shall transition from sch40 PVC to a rigid 90° elbow before extending through the floor. IMC conduit shall extend from the 90° elbow into the bottom of the panel.
- 26.1.3.17** All switchboards, panelboards, MCCs, transformers, disconnects, enclosed circuit breakers, and motor starters shall be labeled with plastic labels having a black background with engraved, white lettering. The labels shall be 1" in height with ½" letter height. Labels may be either fully-adhered or screw-type.

**26.1.3.18** Panelboards shall be identified with panel labels such that service personnel can determine the panel voltage, floor location, and panel contents (normal, life safety, or emergency circuits.) Panel labeling shall be ordered as follows:

“EM, “N,” or “X”	“H” or “L”	“B, G, 1, 2, 3, etc.”
-used to designate panels containing non-life safety loads, but are still connected to the building generator -“N” is used for panels with normal circuits - “X” is used for panels with life safety circuits	“H” is used for High Voltage panels (480V) - “L” is used for Low Voltage panels (208/240V)	- Numbers or letters used to match the building floor level

**26.1.3.19** Examples:

- A 208V panel, serving normal power circuits, located on the 2<sup>nd</sup> floor of a building, shall begin with “NL2.”
- A 480V panel, serving life safety circuits, located on the 1<sup>st</sup> floor of a building, shall begin with “XH1.”
- A 240V panel, serving normal power circuits, located on the basement floor of a building, connected to the building generator, shall begin with “EMLB.”

**26.1.4 Branch**

- 26.1.4.1** Single device boxes shall be a (4”x4”x2.125”) minimum size with appropriate plastering or adapter. Junction and pull boxes shall be a minimum of (4”x4”x2.125”) with appropriate cover.
- 26.1.4.2** Provide at least two (2) separate electrical 20A, 120V receptacle circuits in every residence hall room.
- 26.1.4.3** Provide (2) GFCI receptacles outside of each building entrance. Each receptacle shall be on its own dedicated 20A, 120 volt circuit.
- 26.1.4.4** All receptacle covers shall be labeled with the circuit and panel designation with an adhesive type label.
- 26.1.4.5** Wiring devices shall be hard-use, specification-grade, 125V AC, 20A, back or side wired. Devices to have clamp type terminals. Switches to be rated 277 VAC regardless of system voltage.
- 26.1.4.6** Receptacles shall be provided at each entrance foyer and at least every fifty feet 50’ in all hallways. These receptacles shall be on a dedicated circuit.
- 26.1.4.7** Provide at least one dedicated 20A, 120V receptacle circuit per bathroom.
- 26.1.4.8** Each mechanical room shall have (1) 3 phase, 50A, 250V welder receptacle.
- 26.1.4.9** Provide at least one 20A, 120 VAC GFCI receptacle in each electrical, elevator, mechanical, maintenance storage and trash room, and at each cooling tower and AHU, and on exterior of the building at the front and the rear. Each circuit shall be dedicated to its respective room.
- 26.1.4.10** Receptacles serving vending machines shall have their own 20A dedicated circuit to each receptacle. There shall be one (1) communications outlet for each bank of machines.

- 26.1.4.11 Pre-wired lighting systems shall not be used.
- 26.1.4.12 All conductors in boxes serving receptacles shall be pigtailed so that the device can be removed without interrupting the circuit.
- 26.1.4.13 Junction boxes shall not be located any closer than 4' to any steam piping.
- 26.1.4.14 All device covers shall be approved by the JMU PM.

### 26.1.5 Wiring

- 26.1.5.1 Minimum conductor size for power wiring to be #12 AWG.
- 26.1.5.2 All wire shall be insulated for 600V with stranded copper conductors with THWN or THHN insulation as applicable.
- 26.1.5.3 Use spring-type connectors for #10 AWG and below. Use solderless connectors and splices in #8 AWG and above.
- 26.1.5.4 Grounding shall use exothermic welds where appropriate.
- 26.1.5.5 Conductor color-coding for 208/120V:
  - A-Black
  - B-Red
  - C-Blue
  - N-White
- 26.1.5.6 Conductor color coding for 480/277V
  - A-Brown
  - B-Orange
  - C-Yellow
  - N-Grey

### 26.1.6 Exterior

- 26.1.6.1 Provide a 60A, 3 phase, 208/120V NEMA3R, non-fused, lockable disconnect switch on the exterior of the building. Verify the switch location with the JMU PM.
- 26.1.6.2 Provide metal-backed warning locator tape at half the distance between underground conduit and the proposed finished grade. Locator tape shall be a minimum of 12" above the conduit.

### 26.1.7 Conduit

- 26.1.7.1 All underground wiring shall be installed in sch40 PVC conduit, minimum 1.25" diameter.
- 26.1.7.2 Where two (2) or more conduits are placed in the same ditch, they shall always be placed on elevated base spacers and fully encased in concrete. Intermediate spacers shall be sized to the conduit and provided for all stacked conduits.
- 26.1.7.3 All above-grade conduit size shall be at least ¾". Pre-wired flexible conduit, other than fixture whips, shall not be used. Fixture whips shall be no more than 6' in length.
- 26.1.7.4 No conduit fittings are to be used in concealed areas.
- 26.1.7.5 Compression-type connectors or couplings shall not be used for interior applications. "Die Cast" connectors of any type are prohibited.
- 26.1.7.6 Home run conduits from distribution panels shall be installed directly to the first device. No more than three (3) 90° bends between junction boxes shall be acceptable.

- 26.1.7.7 Install pull string in all empty telecom conduits.
- 26.1.7.8 All telecom conduits shall have a junction box after two 90° bends.
- 26.1.7.9 The use of exposed wire moulding shall be kept to a minimum. When used, Legrand V700 series (or equivalent size) shall be used.

### 26.1.8 Life Safety

- 26.1.8.1 All Life Safety electrical panels are required to have a minimum breaker size of 60A.
- 26.1.8.2 All panels shall have conductors and MCB sized to full panelboard capacity. Sizing of conductors and MCB's shall *not* be based on load calculation only.

### 26.1.9 General Lighting

- 26.1.9.1 The university attracts a varying array of age levels from toddlers to the elderly for the multitude of activities and learning offered. It is our responsibility to design a safe environment for all individuals without sacrificing the natural environment. The designer shall use *Dark Skies* friendly fixtures when possible with a minimum CRI of 80.
- 26.1.9.2 The designer shall use these guidelines as a minimum value to achieve, and be able to demonstrate “good” to “excellent” facial recognition at a distance of 30 feet.
- 26.1.9.3 Sidewalk or area lighting shall match existing campus lighting. Design exterior systems based on performance criteria of existing university fixtures. **JMU** shall provide wiring system design to be used.
- 26.1.9.4 Design consultant shall submit shop drawings for the approval of all proposed lighting fixtures prior to submitting final bid documents.
- 26.1.9.5 Fluorescent fixtures shall be by Lithonia, Hubbell, Metalux or Daybrite. Lenses for troffer type fixtures to be .125” acrylic, parabolic or refraction types depending on application.
- 26.1.9.6 Number of different styles of fixtures shall not exceed 20 per building, including all exit and egress fixtures.
- 26.1.9.7 All emergency lights shall be connected to 277V circuits. Battery backed-up ballasts are not acceptable.
- 26.1.9.8 Dimming of fluorescent lighting systems is prohibited.
- 26.1.9.9 All classrooms shall be equipped with internally illuminated exit signs.
- 26.1.9.10 Provide generator transfer devices to meet egress lighting requirements in the event of a power failure.
- 26.1.9.11 All stairway lighting shall be no higher than 10’ above finished floor height and shall be accessible from a 6’ ladder.
- 26.1.9.12 Exterior lighting, including building mounted units, shall be controlled by a lighting contactor controlled by a photoelectric eye. A hand-off auto switch shall be installed in the cover of contactor enclosure. Time clocks are not acceptable (don’t even ask).
- 26.1.9.13 All multimedia rooms, classrooms and offices shall be provided with a multiple level controlled lighting.
- 26.1.9.14 Office lighting to be controlled by a ceiling mounted sensor with wall mounted toggle switch override suitable for bi-level switching.

**26.1.9.15** Lutron lighting is to be the preferred system for all computer-based lighting. All lighting systems are to be hard-wired where possible. Any WIFI systems are to be approved by JMU IT and/or JMU Electrical department.

### **26.1.10 Interior Lighting Fixtures**

**26.1.10.1** Fluorescent fixtures in new buildings shall utilize T5 lamps.

**26.1.10.2** All LED lighting shall carry at least a 5 year full product replacement warranty.

**26.1.10.3** All usage of LED lighting shall be approved by JMU prior to being included in the construction documents.

**26.1.10.4** Preferred color temperature shall be = 3500°K

**26.1.10.5** Color temperature shall not vary more than 200°K within a connected space.

**26.1.10.6** Recessed “can” type fixture shall only be used in locations with hard ceilings that allow repair access through lamp opening only. The use of these fixtures shall be kept to a minimum regardless of location. The exception is recessed fixtures with a minimum aperture of 7”.

### **26.1.11 Exterior Lighting (LED Only, all measurements taken at ground level)**

#### ***26.1.11.1 Parking Garages & other Covered Parking Areas***

**26.1.11.1.1** Parking Facilities, Garages and covered parking spaces:

**26.1.11.1.2** Average Horizontal Illuminance = 6FC,

**26.1.11.1.3** Average Vertical Illuminance shall produce a uniformity ratio of 25% of the horizontal Illuminance value.

**26.1.11.1.4** These values shall be uniformly distributed throughout the parking facility inclusive of stairs, ramps and elevators.

**26.1.11.1.5** Parking Entrances shall conform to the most current IESNA standard.

#### ***26.1.11.2 Parking Lots (Uncovered)***

**26.1.11.2.1** Average Horizontal Illuminance = 3FC

**26.1.11.2.2** Average Vertical Illuminance shall produce a uniformity ratio of 25% of the horizontal Illuminance value.

**26.1.11.2.3** These values shall be uniformly distributed throughout the parking lot inclusive of likely loitering areas.

#### ***26.1.11.3 Pedestrian Ways (Including walkways and bike paths)***

**26.1.11.3.1** Underpasses: Day – Maintained Horizontal Illuminance = 10FC, Maintained Vertical Illuminance = 5FC

**26.1.11.3.2** Underpasses: Night – Maintained Horizontal Illuminance = 5FC, Maintained Vertical Illuminance = 3FC

**26.1.11.3.3** Dense Foliage Areas: Night – Maintained Horizontal Illuminance = 5FC, Maintained Vertical Illuminance = 3FC

**26.1.11.3.4** Open Area Sidewalks and Footpaths: Night Average Horizontal Illuminance = 3FC, Vertical Illuminance values shall produce a uniformity ratio of 25% of the horizontal Illuminance value, lighting shall extend on both sides of path to a distance of 30 feet. Measurements taken at 36” above surface.

**26.1.11.3.5** Dormitory Commons Areas: Night – Average Horizontal Illuminance values shall produce a uniformity ratio of 23% of the horizontal Illuminance value.

#### ***26.1.11.4 Building***

- 26.1.11.4.1 All building uplighting or accent lighting must be approved by the AVP of Business Services prior to including in the design of a new or existing building.
- 26.1.11.4.2 Multi-colored uplighting or accent lighting of the building facade is not allowed with the exception of Wilson Hall and The Atlantic Union Bank Center where the uplighting is to be in the school colors.

### 26.1.12 Classroom

- 26.1.12.1 In all classroom and mediated meeting rooms provide a projector mounting panel. EPSON PC3 ELPMBFCP, false ceiling plate, 14' to 18' from screen. Provide a 1.5" EMT conduit from panel to deep 4 11/16" junction near or at the podium location. Provide a 20A, 120V dedicated circuit to panel using knock-out provided in panel.
- 26.1.12.2 At podium location, provide control conduit as noted in section (25.7). Additionally, provide a 20A 120V outlet and one (1) telecommunications outlet at podium location.
- 26.1.12.3 Provide box and ¾" conduit for projection screen control at teaching podium location.
- 26.1.12.4 Do not use motion detection to control lighting in lab settings.
- 26.1.12.5 No daylight harvesting is allowed in any lab setting or instructional space.

### 26.1.13 Fire Alarms

- 26.1.13.1 The fire alarm panel shall communicate on the existing 4120 Simplex network.
- 26.1.13.2 Main fire alarm panel shall be located behind a lockable door - remote command centers may be located at the entry foyer or lobby and must have voice capability.
- 26.1.13.3 Fire alarm system to be addressable with voice evacuation, fully supervised and include battery backup. Voice evacuation component shall include public address system capabilities.
- 26.1.13.4 All devices, connections, wire, etc. shall be supplied by the contractor to furnish a fully operating system, whether or not called for by items in plans or specifications.
- 26.1.13.5 Provide 6 (each) spare smoke detectors, heat detectors, audio visual devices and pull stations to JMU upon acceptance of fire alarm system.
- 26.1.13.6 All fire alarm wiring shall be in EMT conduit painted red, with junction covers painted red also. If ceilings are to be painted junction box covers must remain red and conduit must be labeled.
- 26.1.13.7 Extension of existing systems may require addressable devices and programming at the FAC panel. Power supplies may need to be increased in some cases. Notification appliance power supplies need to be easily accessible from the FAC panel.
- 26.1.13.8 Systems shall contain no propriety components that could disallow JMU, or our legally appointed contractor, from performing maintenance or modifications.
- 26.1.13.9 Provide a complete programming point list of FAC panel, including MAPNET address and device text. Verification delay on dorm smoke detectors shall not exceed 60 seconds before sounding a general building alarm.
- 26.1.13.10 No serviceable components shall be installed above ceilings or other concealed areas.
- 26.1.13.11 All FAC cabinets, battery storage cabinets and other miscellaneous cabinets shall be factory provided with CAM locks keyed to Corbin CAT 15.
- 26.1.13.12 All boxes shall be sized to match their corresponding devices.
- 26.1.13.13 Provide spares of any input modules or relays that were used in the system.

- 26.1.13.14 Use the JMU standard audio files (179/180) for fire alarm systems with voice evac (JCI has on file).
- 26.1.13.15 Cat 15 key or Simplex “B” key for all fire panels.
- 26.1.13.16 Provide true “as-built” with conduit pathways, j-boxes, sprinkler valves, drain points and labeled, addressable fire alarm devices.
- 26.1.13.17 Provide separate fire alarm input modules to monitor both the AC power of the sprinkler air compressor and the sprinkler jockey pump.
- 26.1.13.18 Add a heat detector in remotely located fire pump rooms to monitor for low temp/freezing condition. Typical janitor closet spaces shall be designed with a heat detector in lieu of a smoke detector to prevent nuisance alarms caused by steam.
- 26.1.13.19 CO detectors/combo detectors shall be programmed with a specific location attached to each device and be transmitted as a fire alarm not a supervisory signal. If the panel supports voice evacuation a different distinct message shall be played when a CO detectors alarm. “Attention there is an emergency in the building” vs “There is a fire emergency in the building”
- 26.1.13.20 Use Simplex addressable releasing device rather than a third party releasing panel.
- 26.1.13.21 If a building contains a DAS system it is the fire alarm contactors responsibility to provide the correct number of monitoring modules and connect the interface to the individual DAS systems.

### (26.2) GENERATORS

- 26.2.1 Generator package sets shall be manufactured by Caterpillar, Kohler, Blue Star or Cummins.
  - 26.2.1.1 Transfer switches and related components shall be compatible with selected generator-set manufacturer. Acceptable transfer switch manufacturers are Asco, Emerson, and Caterpillar. Proprietary equipment is not acceptable. The ATS control pad shall provide the following display features:
    - 26.2.1.1.1 Utility voltage by phase
    - 26.2.1.1.2 Emergency voltage by phase
    - 26.2.1.1.3 Frequency by phase
  - 26.2.1.2 The generator set shall be located outside of the building in a discreet location.
  - 26.2.1.3 When available, natural gas shall only be used to fuel generators up to 25kW. If a diesel generator is used, it shall be fueled by #2 diesel and be equipped with a skid mounted fuel tank. The tank shall be located in an accessible location to permit refueling.
  - 26.2.1.4 JMU may require additional emergency power beyond the typical code requirements.
  - 26.2.1.5 Diesel generators shall meet all current Environmental Protection Agency (EPA) Standards of performance for Stationary Compression Ignition Internal Combustion engines and shall include the following features:
    - 26.2.1.5.1 NEMA 3R 75-db housing for outdoor installation with lockable access doors
    - 26.2.1.5.2 Control panel viewing window
    - 26.2.1.5.3 Engine mounted solid-state start-up/stop system
    - 26.2.1.5.4 Automatic load transfer

- 26.2.1.5.5 Keypad operated run/stop switch located on transfer switch
  - 26.2.1.5.6 Coolant temperature gauge
  - 26.2.1.5.7 DC voltmeter
  - 26.2.1.5.8 Running time meter
  - 26.2.1.5.9 Lamp test switch
  - 26.2.1.5.10 Oil pressure gauge
  - 26.2.1.5.11 Fault reset switch
  - 26.2.1.5.12 Low oil pressure shut down
  - 26.2.1.5.13 Low fuel shut down
  - 26.2.1.5.14 Engine block heater
  - 26.2.1.5.15 Dual range AC ammeter and volt meter
  - 26.2.1.5.16 Phase selector switch
  - 26.2.1.5.17 Frequency meter
  - 26.2.1.5.18 Rheostat for voltage adjustment
  - 26.2.1.5.19 Rheostat for frequency adjustment
  - 26.2.1.5.20 Critical grade muffler with rain cap
  - 26.2.1.5.21 Main line circuit breaker
  - 26.2.1.5.22 Battery charger (equalizer float type)
  - 26.2.1.5.23 Over speed and over crank shutdown
  - 26.2.1.5.24 Batteries
  - 26.2.1.5.25 Secure mounting to a permanent foundation
  - 26.2.1.5.26 Relays or active contact points for generator running and for common faults to tie in monitoring system.
- 26.2.1.6 Generator set shall not serve multiple buildings.
- 26.2.1.7 Contractor to supply initial full tank of fuel and is responsible for refilling tank after all testing has been performed. Contractor to supply documentation from a fuel analysis that is performed prior to start-up. This analysis should test the following parameters:
- 26.2.1.7.1 Cetane Index
  - 26.2.1.7.2 Water
  - 26.2.1.7.3 Water and Sediment
  - 26.2.1.7.4 ISO Cleanliness
  - 26.2.1.7.5 API Gravity
  - 26.2.1.7.6 Distillation
  - 26.2.1.7.7 Micro-organisms(both bacteria & fungus)
- 26.2.1.8 Generators < 250Kva shall provide a means of connecting a portable load bank via a spare breaker or load bank dock and shall be easily accessible.
- 26.2.1.9 Generators > 250Kva shall be supplied with an external load bank, either mounted on the generator or permanently mounted within 10' of the generator. The load bank shall be sized as to provide no less than 75% of the generators Kva rating. The load bank shall have the ability to manually adjust the load. The load bank shall also have the ability to be turned off when not in use.
- 26.2.1.10 Generator shall be able to communicate warnings and critical alarms to the BAS. Locate generator annunciator panel near building main fire alarm control panel.
- 26.2.1.11 Shunt trip breakers shall be installed if the generator goes into fault shutdown.

- 26.2.1.12** Automatic Transfer Switches (ATS) shall be closed-transition type only.
  - 26.2.1.12.1** Provide at least one spare ¾" conduit and pull string between the generator enclosure and the ATS switch.
  - 26.2.1.12.2** 6 extra #12 awg wires shall be pulled in the D.C. conduit from the ATS to the generator.
- 26.2.1.13** Generator shall be provided with at least two (2) duplex convenience outlet, mounted in an accessible location within the generator enclosure. This outlet shall be fed from a minimum 20 amp capacity breaker that is clearly marked and is also on emergency power.
- 26.2.1.14** Provide JMU with two (2) sets of operation and maintenance manuals at the time of field testing. One set shall be delivered directly to the Emergency Power Shop along with one set of Genset wiring diagrams, a parts cd, all other related repair and/or troubleshooting manuals and the warranty statement.
- 26.2.1.15** All equipment, parts and related components shall be fully warrantied against defectiveness or workmanship for a period of no less than five (5) years from the date of the approved completed site field testing. It shall include all parts, labor and travel costs for the full five (5) year term and feature no deductibles.
- 26.2.1.16** Contractor shall provide a one (1) year preventive maintenance contract to include the following items at no extra cost to JMU:
  - 26.2.1.16.1** Four (4) quarterly visits, the last to include fuel filter, oil filter and oil change
  - 26.2.1.16.2** Battery acid testing
  - 26.2.1.16.3** Third visit shall also perform a coolant and engine oil test and results shall be provided to JMU Emergency Power Shop within two (2) weeks after visit



### (27.1) TELECOMMUNICATIONS

#### 27.1.1 General

- 27.1.1.1 All telecommunications cables, jacks, and components of emergency phone systems, with the exception of power, shall be furnished by JMU.
- 27.1.1.2 All conduits shall contain bushings and 210lbs tensile strength pull strings.
- 27.1.1.3 No conduit shall have individual bends that exceed 90°.
- 27.1.1.4 Equipment not directly related to telecommunications shall not be located in telecommunication rooms.

#### 27.1.2 Building Telecommunications Entrance

- 27.1.2.1 Building entry shall consist of a minimum of (6) 4"sch40 PVC conduits from the building Main Distribution Frame (MDF) into the utility tunnel or manhole specified by JMU Telecommunications Department (JMU TD). Manhole and conduit placement shall be coordinated with the Assistant Director of the JMU TD to determine the best location to connect with our existing infrastructure and network.
- 27.1.2.2 Conduits shall enter MDF within 4" of a wall.
- 27.1.2.3 There shall be one MDF per building located on the lowest floor practical without the threat of water ingress.

#### 27.1.3 Main Distribution Frame (MDF) & Intermediate Distribution Frame (IDF)

- 27.1.3.1 The MDF is a space that serves as the central point for inter-floor and inter-building connections. The MDF shall be minimally at least 12'x14' and the IDF shall be minimally at least 10'x12", and both shall have a minimum clear ceiling height of 10'. If other trades have equipment within the MDF/IDF, the room size shall be increased accordingly. Variations to these measurements shall only be approved by Assistant Director of JMU TD.
- 27.1.3.2 The MDF and IDFs shall be vertically aligned between floors when possible.
- 27.1.3.3 There shall be one MDF per building located on the lowest floor practicable.
- 27.1.3.4 There shall be at least one (1) IDF per floor, unless building size permits otherwise.
- 27.1.3.5 The MDF may also function as IDF for the floor in which it resides.
- 27.1.3.6 Finished ceilings and carpets are not allowed. Concrete floors shall be sealed.
- 27.1.3.7 Fire rated ¾" plywood backer board shall be installed over finished sheetrock wall covering to minimize dust. The backer board shall be painted white in color, the stamp of the fire rated plywood needs to be taped prior to being painted and facing in so it can be inspected by the Fire Marshall. The plywood shall be installed on all walls from 2' above the finished floor to 10' above the finished floor.
- 27.1.3.8 Lighting for these rooms shall be a minimum of 46 foot-candles in the horizontal plane and 18.6 foot-candles in a vertical plane. Fixture locations shall be coordinated with JMU TD PM.
- 27.1.3.9 The MDF/IDF shall not be located more than 250' of actual conduit from any work area outlet. If the building is too large to meet the requirement, one or more IDF rooms shall be used to ensure that no conduit run exceeds 250' from either MDF or IDF.

## DIVISION 27 – COMMUNICATIONS

- 27.1.3.10 The temperature and humidity shall be controlled in accordance with the manufacturers' specifications for the equipment anticipated to be housed in the Telecommunications Rooms. In general, temperature should be maintained between 50oF and 80oF and maintain a relative humidity of less than 55% and a minimum of at least one air change per hour. If the building has a generator installed, it shall be on generator backup via a closed transition transfer switch.
- 27.1.3.11 The climate control for the MDF/IDF shall be independent from any other space.
- 27.1.3.12 No water, drain, condensing lines, or pipes shall be routed through MDF/IDF, above or below.
- 27.1.3.13 No trades shall use any conduits dedicated to telecommunications at any time.
- 27.1.3.14 Entry to the MDF/IDF shall be from a public corridor. Entry through any other space shall only be approved by the JMU TD Assistant Director.
- 27.1.3.15 Entry to MDF/IDF shall have a door minimally sized to 3' that is lockable and swings out.
- 27.1.3.16 Lights shall be protected fixtures switched without occupancy sensors.
- 27.1.3.17 In addition to power requirements for programmed space use, there shall be a duplex work outlet receptacle in an accessible location.
- 27.1.3.18 MDF/IDF rooms shall be served by a minimum of two (2) 20A circuits per equipment rack. Exact number of equipment racks and locations shall be specified by the JMU TD.
- 27.1.3.19 When available, all circuits dedicated to the equipment racks shall be on generator backup equipped with a closed transition transfer switch.
- 27.1.3.20 In some buildings, major voice and data equipment beyond the norm and may need to be installed in the MDF. In such special cases, additional power shall be supplied in accordance with the specifications of the equipment manufacturer.
- 27.1.3.21 JMU PM shall ensure that the A/E verifies, and documents all planned equipment during the preliminary drawing phase.
- 27.1.3.22 Four (4) 4" conduits shall connect the MDF to the first IDF and each IDF to the IDF above itself dedicated for Telecom use only.
- 27.1.3.23 MDF/IDF needs to be situated so that three of the four walls do not restrict the installation of conduit(s) or pathways.

### 27.1.4 Work Areas

- 27.1.4.1 Each room of 100ft<sup>2</sup> or less is to be considered a work area.
- 27.1.4.2 For rooms that exceed 100ft<sup>2</sup>, a work area is to be considered every 100ft<sup>2</sup>, or portion thereof, within the room.

### 27.1.5 Outlet Boxes

- 27.1.5.1 Minimum of (2) 4 11/16" flush mount outlet boxes shall be installed in each work area.
- 27.1.5.2 Outlets shall be installed on opposing walls from each other.
- 27.1.5.3 Outlet locations shall be verified and approved by the JMU TD at the preliminary plan phase. The JMU PM shall coordinate and confirm this process.
- 27.1.5.4 Each work area outlet shall have a single gang plaster ring installed to accommodate the installation of a standard single gang faceplate.

## DIVISION 27 – COMMUNICATIONS

- 27.1.5.5 Outlet boxes shall also be installed as required for alarm, card readers, wireless access points, emergency phones, elevators and other special use circuits.
- 27.1.5.6 In residential rooms (dorm room), outlets shall be elevated above designed furniture.

### 27.1.6 Horizontal Distribution System

- 27.1.6.1 Each work area outlet shall be directly connected by a 1" conduit to the IDF or MDF located on the same floor. Exposed conduit is not desired and its use shall be approved by the JMU PM.
- 27.1.6.2 All conduits shall stub-out no further than 3" into the MDF or IDF.
- 27.1.6.3 All conduits shall be labeled with work space numbers.
- 27.1.6.4 All horizontal conduits shall enter the MDF/IDF from an adjacent above-ceiling space, and at no point below 90" A.F.F. If conduits must enter through the MDF/IDF floor, it shall be pre-approved by the JMU TD and conduits may not exceed two (2) rows deep.
- 27.1.6.5 Rooms may not have service fed from two different IDFs or MDF (No rooms shall be split and have services provided by two separate TRs.)
- 27.1.6.6 All junction boxes shall be installed in an accessible location even after project is complete. Junction boxes shall be covered and placed above ceiling in a public corridor.
- 27.1.6.7 Other conduits for special circuits, sound, security, card readers, or fire alarms that must enter the MDF or IDF, shall be grouped separately from the work area outlet conduits.
- 27.1.6.8 All above-grade telecommunications pathways shall be 1" EMT conduit with solid steel connectors.
- 27.1.6.9 Communications floor box and poke-through box conduits shall run to the nearest wall with ceiling access and then to an above-ceiling junction box or pull-box, before connecting to the nearest MDF/IDF.

### 27.1.7 Elevators

- 27.1.7.1 Equipment installed within the elevator cart shall be compatible with the telephone service provided by the JMU TD and shall only be programmable to dial a 5-digit extension directly to the JMU Police dispatcher.
- 27.1.7.2 "Outside call center" service shall not be acceptable.
- 27.1.7.3 Emergency Communications System: System shall provide two-way voice communication without using a handset and provide visible signals that indicate when system has been activated and when dispatcher has responded. Upon activation, system dials a pre-programmed number to JMU's Police dispatcher and identifies elevator location to dispatcher through Telecommunications phone switch. When elevator phone is called from dispatcher no additional keypad entry has to be entered by dispatcher other than the original five digits for phone to have two-way communications. Phone shall also disconnect when dispatcher ends call or "hangs up" with no additional keypad entry by dispatcher. System is contained in flush-mounted cabinet with identification, instructions for use and battery backup power supply.

## DIVISION 27 – COMMUNICATIONS

**27.1.7.4** Emergency Landing Intercoms (ELI) shall use the emergency phone equipment provided by JMU TD for the required two-way communication. These devices shall be recessed, and the size of the box shall be considered in furring out the wall.

**27.1.7.5** Add network drop to each elevator terminated at the same location as the elevator phone drop

### 27.1.8 Grounding

**27.1.8.1** A grounding bar shall be installed in the MDF and each IDF. The grounding bars shall be electrically connected to each other and to the main building ground at the building electrical service entrance. All grounding shall be designed in accordance with ANSI/TIA-607-D.

### 27.1.9 Emergency Phones

**27.1.9.1** Gai-Tronics brand equipment is the only brand used at JMU.

**27.1.9.2** The height of telecommunications outlets for emergency phones shall be specified by the JMU TD PM.

**27.1.9.3** Any exterior or parking garage emergency phones shall contain a blue light.

**27.1.9.4** Every stairwell shall have a surface mounted emergency phone installed on the landing of every floor.

**27.1.9.5** Electrical power is only required for blue light emergency phones.

**27.1.9.6** Any “pole” style emergency phone shall require the use of a template that will be supplied by the JMU TD.

### 27.1.10 Junction Boxes

**27.1.10.1** Junction boxes shall be a minimum of 4 11/16" X 4 11/16".

**27.1.10.2** Junction boxes shall be installed as a pull point every two (2) 90° bends in the horizontal cabling conduits. Conduits shall enter in-line or in a “straight-thru” manner, not to be used as a 90° bend.

**27.1.10.3** Junction boxes shall be located within a public corridor.

**27.1.10.4** If more than two (2) conduits are within the same area they shall be located in a larger pull box.

**27.1.10.5** Any above ceiling junction box over 2' X 2' shall have a lid(s) that can be removed through a drop ceiling.

**27.1.10.6** Any junction box with a measurement of 32” or larger shall have split covers.

**27.1.10.7** Wiring troughs shall not be used.

### 27.1.11 Roof Penetrations

**27.1.11.1** A roof penetration shall be required for future use. There shall be a 3” conduit run from roof penetration to the upper most IDF with a weather head installed.

**27.1.11.2** Roof penetration shall not be above MDF/IDF.

### 27.1.12 Wireless Access Points (WAP)

**27.1.12.1** WAP locations shall be determined by the JMU Information Technology department in conjunction with JMU TD.

**27.1.12.2** All WAPs shall have a 4 11/16” x 4 11/16” junction box with a single gang plaster-ring in order to maintain the infrastructure bend radius.

## DIVISION 27 – COMMUNICATIONS

- 27.1.12.3 All WAP boxes shall have conduits installed in accordance with outlet boxes and conduit specifications previously stated.
- 27.1.12.4 WAPs in "drop ceiling" areas shall have outlet boxes installed not more than 12" above finished ceiling and include single gang plaster ring
- 27.1.12.5 WAPs installed in a drywall or "hard" ceiling shall have flush-mounted outlet boxes with a single-gang plaster ring.

### 27.1.13 Classrooms

- 27.1.13.1 Classrooms that contain a projector shall require a telecommunications outlet
- 27.1.13.2 Communications outlets shall be piped back to the nearest MDF/IDF.
- 27.1.13.3 Any podium location shall require a telecommunication outlet.

### 27.1.14 Manhole Specifications

- 27.1.14.1 Contractor shall prepare area, furnish, and install a load bearing pre-cast concrete manhole of 6'x8'x7'h.
- 27.1.14.2 The manhole shall be placed on a 12" gravel base and contain a French drain or approved drainage system within the manhole.
- 27.1.14.3 Contractor shall ensure that all joints are properly sealed to prevent entrance of water.
- 27.1.14.4 Contractor shall ensure conduit penetrations into manhole be adequately sealed to prevent entrance of water.
- 27.1.14.5 Point of conduit entry into manhole shall be as close to a corner location as possible.
- 27.1.14.6 The manhole shall have a 3' diameter removable cover labeled in a way that indicates the manhole is for communications. The manhole cover shall be load bearing and suitable to withstand traffic.
- 27.1.14.7 Contractor shall furnish and install access ladder, racking on all four sides and pulling eyes within the manhole.
- 27.1.14.8 The manhole shall be installed so the cover is flush with existing grade.

### 27.1.15 Buried Conduit Specifications

- 27.1.15.1 Contractor shall furnish and install 4" schedule 40 PVC.
- 27.1.15.2 Contractor shall ensure conduits are separated by spacers intended for the purpose.
- 27.1.15.3 Contractor shall install conduits on a bed of sand or fine rock dust and encase conduits in a 3" envelope of slurry or concrete with a magnetic tape installed 12" above the concrete.
- 27.1.15.4 Contractor shall ensure backfill material shall be free of rock.
- 27.1.15.5 Conduits shall be installed so the top of the concrete is minimally 24" below finished grade.
- 27.1.15.6 Conduit runs shall not exceed 500' between pulling points. The sum of all bends between pulling points shall not exceed 180° degrees and no single bend shall be more severe than a sweep 90°.
- 27.1.15.7 Conduit penetrations into manholes or buildings shall be adequately sealed to prevent the entrance of water.
- 27.1.15.8 Conduit runs between manholes shall consist of six (6) 4" conduits unless otherwise specified.

## DIVISION 27 – COMMUNICATIONS

- 27.1.15.9** Conduit runs between a manhole and a building shall consist of six (6) 4" conduits unless otherwise specified.
- 27.1.15.10** After installation of buried conduits all disturbed areas shall be returned to their pre-installation condition.
- 27.1.15.11** Contractor shall bore underground areas where applicable.
- 27.1.15.12** The contractor shall be responsible for conforming to all applicable Erosion and Sediment Control Regulations.
- 27.1.15.13** The contractor shall coordinate all work with JMU TD Project Manager.
- 27.1.15.14** All buried conduit pathways shall include an accessible and locatable tracer wire.

**(27.1) DISTRIBUTED ANTENNA SYSTEMS (DAS)**

**27.1.1 Head-End Space**

- 27.1.1.1 All Public Safety Distributed Antenna System (PS DAS) design and components, with the exception of power and conduit/cable raceway shall be furnished by JMU TD contractor.
- 27.1.1.2 PS DAS Head-End Equipment to be located the highest IDF based on proximity to donor antenna, the closer to donor antenna roof penetration the better, or in the MDF.
- 27.1.1.3 Selected room will require increased square footage to accommodate additional PS DAS related equipment (i.e. + 500 S/F)
- 27.1.1.4 Provide 4’ x 8’ plywood BDA Back Board in designated head-end location with at least 36” of depth space out from wall for mounted and free-standing PS DAS equipment on the floor unobstructed by other conduits or utilities.
- 27.1.1.5 The requirement for (11) eleven fire alarm system test points for each of the (2) two PS DAS systems (UHF 450-470 MHz & 700-800 MHz) and their associated BBUs will be required as per outlined in the table below. The port should be connected only to the fire alarm control panel. The default length of the cable that is provided to connect to a FACP is 6m (19.5ft). The EXT alarm wiring cannot exceed 30m (98.5ft).

Pin	Color	Pin Description (24 pins)	ADRF External Alarm Box Pin Description	Alarm Type
A	Black	Donor antenna malfunction_P	1-POS	Output
B	Black	Donor antenna malfunction_N	1-NEG	Output
C	Brown	Active RF device malfunction_P	2-POS	Output
D	Brown	Active RF device malfunction_N	2-NEG	Output
E	Red	Low battery capacity (70%)_P	3-POS	Output
F	Red	Low battery capacity (70%)_N	3-NEG	Output
G	Orange	System component malfunction_P	4-POS	Output
H	Orange	System component malfunction_N	4-NEG	Output
J	Yellow	Normal AC Power_P	5-POS	Output
K	Yellow	Normal AC Power_N	5-NEG	Output
L	Green	Loss of normal AC Power_P	6-POS	Output
M	Green	Loss of normal AC Power_N	6-NEG	Output
N	Blue	Battery charger failure_P	7-POS	Output
P	Blue	Battery charger failure_N	7-NEG	Output
Q	Purple	Summary Alarm_P	8-POS	Output
R	Purple	Summary Alarm_N	8-NEG	Output
S	Grey	Donor Antenna Disconnect_P	9-POS	Output
T	Grey	Donor Antenna Disconnect_N	9-NEG	Output
U	White	Oscillation Alarm_P	10-POS	Output
V	White	Oscillation Alarm_N	10-NEG	Output
W	Pink	ANN Disconnection_P	11-POS	Output
X	Pink	ANN Disconnection_N	11-NEG	Output
Y	Light Blue	N.C.	-	-
Z	Light Blue	N.C.	-	-

## DIVISION 27 – COMMUNICATIONS

- 27.1.1.6 Monitoring modules and connections from the fire alarm system to the PS DAS system will be provided by and completed by the fire alarm contractor.
- 27.1.1.7 Monitoring modules shall be installed on the PS DAS Backboard. Location to be determined by the JMU Telecommunications PM.

### 27.1.2 Power Requirements

- 27.1.2.1 Dedicated PS DAS Electrical Circuit tied to Emergency Generator. (1) 120v 20 Amp Isolated Circuit - Quad Outlet at edge of 4'X 8' PS DAS Backboard @ 18" AFF. Location to be determined by the JMU Telecommunications PM.

### 27.1.3 Pathways

- 27.1.3.1 Depending on primary pathways, conduit/sleeves may be required as necessary to maintain fire rating.
- 27.1.3.2 (1) Additional 4" riser conduit with a maximum of a single 90-degree radius in a 30-foot run. Will be required from lowest floor to upper most floor.

### 27.1.4 Roof Penetration and Rooftop Antenna Mounting Location

- 27.1.4.1 (1) 3" rigid conduit roof penetration (location designated by PS DAS Installer or JMU Telecommunication PM) to be stubbed at least 24" above roofline with weather head.
- 27.1.4.2 Roof penetration conduit shall be capable of extending up to a height of 12' mast for donor antennas if needed.
- 27.1.4.3 Roof penetration conduit should be securely attached to the structure to handle necessary wind loading and weight of donor antennas.
- 27.1.4.4 Weighted Sled would be the most likely alternative if a suitable structural steel mounting point is not available.
- 27.1.4.5 Structure and location shall be designed to support antenna mount or sled load.

### 27.1.5 Grounding and Lightning Protection Requirements: (Rooftop, Head-End, and Coax Cable)

- 27.1.5.1 Grounding block to be provided at PS DAS backboard. (JMU Telecommunication PM to designate location)
- 27.1.5.2 Grounding point required within 6" of the roof penetrating conduit on the interior of the building.
- 27.1.5.3 Roof penetrating conduit/mast to be connected to the rooftop grounding system.

### (31.1) EXCAVATION & GRADING

#### 31.1.1 Excavation

- 31.1.1.1 The limits of all areas to be excavated shall be outlined in white paint, by the contractor requesting utility location services.
- 31.1.1.2 Any engineering firm performing design work on campus shall be responsible to call in a design ticket before preliminary site survey work takes place.
- 31.1.1.3 No excavation work shall begin until all temporary ESC controls and plant protection measures are in place and the digging permit has been cleared with VA811.
- 31.1.1.4 Strip topsoil to depth of 6" in a manner to prevent intermingling with underlying subsoil on other waste materials.
- 31.1.1.5 Stock pile topsoil from edge of excavations without intermixing with subsoil. Grade and shape stockpiles to drain surface water. Cover to prevent windblown dust and erosion by water.
- 31.1.1.6 Excavate to subgrade elevations regardless of the character of surface and subsurface conditions encountered. Unclassified excavation materials may include rock, soil and any unforeseen obstructions. No changes in the contract sum or the contract time shall be authorized for rock excavation or removal of obstructions without prior consent from JMU. Cost shall be predetermined in the allowance summary by contract.
- 31.1.1.7 All open excavations shall be protected by temporary fencing or other approved means to ensure public safety. Not more than 100 linear feet of trench may be opened at one time. The contractor should close completed trench immediately upon approved inspection. Excavated material shall be placed on the uphill side of the trench. All abounded wires, pipes, etc. shall be removed from the fill material prior to replacement in the trench.
- 31.1.1.8 Contractor shall furnish, erect and maintain all shoring, sheeting, bracing and pumping equipment required to support and protect all excavations. Contractor shall provide all barriers, signs, and lights required to protect workmen and the public in and around excavated areas.
- 31.1.1.9 All pipe ends shall be closed while unattended.
- 31.1.1.10 Blasting will be allowed with the approval of the JMU PM. All necessary precautions shall be taken to prevent damage to existing buildings, utilities, etc. The use of blasting mats is required. Blasting shall be accomplished by a company certified and licensed to do this type of work. The contractor shall be responsible for obtaining all local, state and federal permits.

#### 31.1.2 Grading

- 31.1.2.1 Place backfill and fill soil materials in layers not more than 8" in loose depth for materials compacted by heavy compaction equipment, and not more than 4 inches in loose depth for material compacted by hand-operated tampers.
- 31.1.2.2 Grading operations shall avoid soils and debris spillover. Large areas to be graded shall limit clearing the ground too far in advance, to limit erosion. Dust control shall be provided during all grading operations.

## DIVISION 31 - EARTHWORK

- 31.1.2.3** Slope gradients shall be designed to facilitate surface drainage and limit soil erosion. The preferred maximum slope for plated banks is 3:1. In geologically stable areas, up to 1:1 may be permitted for exposed rock slopes. Slopes for turf areas should be 1.5% minimum cross fall for drainage, and hardscapes should be between 1% and 2%.
- 31.1.2.4** Provide clean #57 backfill within 5' of all exterior walls adjacent to building.
- 31.1.2.5** Rocks shall not be used for any fill material. All excavated rock shall be removed from university property unless otherwise approved by project manager.
- 31.1.2.6** Trench backfill under paved areas, roadways, concrete walkways, patios, plazas and/or any other areas intended to have a permanent surface, shall be of flowable, cementitious type fill material. This is commonly referred to as "slurry."
- 31.1.2.7** All fill shall be of proper type and proper compaction. All final grading shall be smooth and blended with existing contours. All exposed stones and other debris shall be removed prior to application of topsoil or any other fill.

## DIVISION 32 – EXTERIOR IMPROVEMENTS

### (32.1) SITE

#### 32.1.1 General

- 32.1.1.1 Do not commence site clearing operations until temporary erosion and sediment control and plant protection measures are in place.
- 32.1.1.2 Protect and maintain JMU owned benchmarks and survey control points from disturbance throughout entire construction process.
- 32.1.1.3 JMU reserves the right to salvage material and equipment. The A/E shall consult with the JMU PM to determine needs per individual project.
- 32.1.1.4 Each project shall have an appropriate sign identifying the project name and scope. Sign shall be visible from the public way outside of the construction fence and its location shall be approved by JMU Director of FP&C.
- 32.1.1.5 All debris shall be removed from the site and hauled off campus. All paved areas shall be thoroughly washed. This level of cleanliness shall be maintained throughout the project.

#### 32.1.2 Utilities

- 32.1.2.1 All underground utilities design shall be conceived and designed with an “easement approach” in mind, thus facilitating their maintenance and accessibility. The schematic design utility site plan and all other utility site plans thereafter shall clearly indicate the outline of this utility easement.
- 32.1.2.2 The contractor shall secure, at the contractor’s expense, all utilities hookups and access roads for all construction projects. The contractor shall be required to make all utility connections and is responsible for the removal of all connections and any repairs that may need to be made. This work is to be scheduled with the JMU PM.
- 32.1.2.3 Connections made to existing JMU systems shall not be done without prior approval and coordination with the University. A written notice shall be submitted to the JMU PM 14-days in advance of the work being performed detailing location, manner and time of the connections. As soon as temporary connections are no longer required, they shall be immediately removed by the contractor.
- 32.1.2.4 All utility connections to JMU utilities shall be metered and charged at the current rates. The contractor shall supply and install all metering devices. Metering devices shall be periodically inspected and read by JMU personnel throughout the entire project. Any changes, replacements or alterations to any metering devices shall first be approved by the JMU PM prior to the changes being made. Meters shall be installed in accessible location.
- 32.1.2.5 Steam connections shall provide for condensate return to the JMU system.
- 32.1.2.6 As-built drawings shall mark all located lines, whether new or existing.
- 32.1.2.7 Provide metal-backed warning tape at all underground utility lines. Tape shall be located at half of the distance between the top of the utility line and the approved finished grade height as shown on the site plan.
- 32.1.2.8 Provide a #10 green insulated conductor in all utility trenches, regardless of the type of piping it contains. Both ends of the wire shall be accessible and of sufficient length to provide grade-level access, and be contained within approved junction boxes or manholes.

## DIVISION 32 – EXTERIOR IMPROVEMENTS

**32.1.2.9** Manhole covers shall be designed to VDOT load bearing requirements and shall include identification of the system involved (steam, sanitary sewer, storm drains, electric, telecom, etc.) All manholes shall be at least to ground level.

### **32.1.3 Surrounding Areas**

**32.1.3.1** Do not close or obstruct streets, pedestrian walkways or other adjacent facilities without direct permission from the Director of Facilities Engineering & Construction.

**32.1.3.2** Provide alternative route around closed or obstructed traffic ways or sidewalks.

**32.1.3.3** Provide traffic and/or pedestrian signage in the event an alternate or otherwise altered route is provided.

**32.1.3.4** Minimize interference, to the greatest extent possible, with all adjoining roads, streets, walks and other adjacent occupied facilities during excavation operations.

### **32.1.4 Site Protection**

**32.1.4.1** Standard construction site fencing should be 8' foot chain link fencing with top rail and a sight-restrictive fabric screening.

**32.1.4.2** All chain link fencing and gates shall be made of 9 gauge, 2" weave with Class 2 hot-dipped galvanized wiring. Fencing shall be black vinyl coated.

**32.1.4.3** All posts and rails shall be at least Schedule 40 hot-dipped galvanized or high-tensile galvanized steel piping. Posts shall be driven and all exposed metal painted black. Top and bottom rails shall also be painted black. All gates and hardware shall also be painted black.

**32.1.4.4** All construction gates should be double locked using contractor and JMU supplied locks.

### **32.1.5 Lighting**

**32.1.5.1** Facilities engineering will provide the concrete base detail for lighting units. Pole base detail is located in the Appendix.

**32.1.5.2** All other site lighting details are located in the electrical section.

### **32.1.6 Construction Trailer**

**32.1.6.1** Location shall be approved prior to mobilization and shown on site plan.

**32.1.6.2** Provide a full mobilization plan at the preliminary drawing phase.

**32.1.6.3** Contractor shall contact the local telephone company for service, telephones and fax machines, etc. The contractor will be permitted to access the telephone company via JMU's telecommunication system. This shall be coordinated with the JMU PM.

### (32.2) PARKING LOTS

#### 32.2.1 General

- 32.2.1.1 All parking lots are to have “CG-7” curb & gutter adjacent to any landscape area. Parking lots are to have “CG-6” curb & gutter in all other locations.
- 32.2.1.2 All non-ADA parking stalls shall be a minimum of 9’ in width and 18’ depth.
- 32.2.1.3 Provide ADA-compliant parking within 25’ of the building.
- 32.2.1.4 Coordinate motorcycle parking requirements with JMU Parking Services.

#### 32.2.2 Standard parking lots

- 32.2.2.1 This shall be used for all general use parking lots.
- 32.2.2.2 Sub-grade shall be compacted to a minimum of 95% maximum proctor density.
- 32.2.2.3 Provide a 6” layer of #21A stone compacted to >95%.
- 32.2.2.4 Provide a 2” layer of SM-9.5AL bituminous concrete surface.

#### 32.2.3 Heavy parking lots

- 32.2.3.1 This shall be used for all areas subject to eccentric vehicular loading.
- 32.2.3.2 Sub-grade shall be compacted to a minimum of 95% maximum proctor density.
- 32.2.3.3 Provide a 6” layer of #21A stone compacted to >95%.
- 32.2.3.4 Provide a 3” layer of BM-25 bituminous concrete base layer.
- 32.2.3.5 Provide a 2” layer of SM-9.5AL bituminous concrete surface.

#### 32.2.4 Asphalt Cut and Patch Requirements

- 32.2.4.1 All open pavement cuts shall comply with the VDOT “Special Provisions for Pavement Open Cuts” guidelines.

#### 32.2.5 Parking Lot Signage

- 32.2.5.1 ADA parking lot signage shall be designed and installed to meet all ADA requirements
- 32.2.5.2 Pole mounted ADA parking signage shall be located a minimum 3’-0” from the back of curb.
- 32.2.5.3 Parking lot signage design and location shall be reviewed and approved by JMU Project Manager prior to the start of fabrication.

### (32.6) LANDSCAPING

#### 32.3.1 General

- 32.3.1.1 All campus landscaping for both new and existing buildings and facilities shall comply with these guidelines.
- 32.3.1.2 All landscaping shall comply with the approved site plan landscaping design.
- 32.3.1.3 Contractor shall protect the campus landscape before, during and after construction.
- 32.3.1.4 Tree protection fencing shall be installed around all existing trees noted in the approved landscaping plan to remain. Fencing shall extend a distance from the trunk of 1.25 feet per inch of trunk diameter or 6', whichever is greater. Fencing shall be installed prior to any equipment arrival on site. Fencing shall be galvanized chain link, 4' in height. Fence shall be maintained for the duration of the project, and no storage, stockpiling or vehicle parking shall occur any time within the tree protection fencing.
- 32.3.1.5 Roots encountered outside of the tree protection area require notifying the JMU PM.
- 32.3.1.6 The contractor shall be fully responsible for the establishment, protection, watering and growth of all new grasses and other plantings. Grass shall be grown to 85% germination by the completion of the project.
- 32.3.1.7 Plants shall be fully guaranteed for one full year beyond the issuance of the Certificate of Occupancy. Replacement of failed plantings shall take place within two (2) weeks of notification.
- 32.3.1.8 Backfill in other areas that are to be planted, sodded or otherwise landscaped shall be clean fill within 6" of finished grade. Remainder to be clean, sifted and ½ inch screened high quality topsoil. This fill shall be 90% compacted in 6" lifts.
- 32.3.1.9 The F.M. landscaping department reserves the first rights to contract any or all of the required landscaping on new or renovation construction projects.

#### 32.3.2 Plantings

- 32.3.2.1 Provide a 24" minimum root barrier for all trees.
- 32.3.2.2 No tree smaller than 1.25" caliper shall be specified.
- 32.3.2.3 All trees shall be properly staked to avoid damage.
- 32.3.2.4 Trees shall not be planted with the wire cages, grow bags, plastic pots or any other root-encasing device.

#### 32.3.3 Lawns

- 32.3.3.1 *JMU Campus Sturdy Sun & Shade Grass Seed Mixture* (300 lbs. per acre):

- Bullseye Tall Fescue 30.15%
- Magellan Tall Fescue 30.07%
- Turbo Tall Fescue 29.06%
- Corsair Kentucky Bluegrass 9.90%

#### 32.3.4 Hydro-seeding

- Do not overspray on building or established planting beds.
- Low areas subject to surface drainage shall be sodded in lieu of hydro-seeding.

## DIVISION 32 – EXTERIOR IMPROVEMENTS

### 32.3.5 Drainage

- 32.3.5.1 Where possible, the drainage design should retain the site's natural drainage pattern. Other than in approved site drainage elements, the ponding of water on site ground surfaces is not allowable.
- 32.3.5.2 Hardscape area drainage shall have a minimum slope of one quarter inch per foot (1/4":1') away from building(s).
- 32.3.5.3 No landscaping features shall divert water towards buildings.
- 32.3.5.4 The landscape drainage concept shall be coordinated with the approved site drainage plan.

### 32.3.6 Water Conservation

- 32.3.6.1 The designer shall consider landscape design concepts that incorporate water and energy conservation methods. Include appropriate provisions for irrigation equipment, the selection of drought-resistant plantings and the design of adequate lawn and other maintenance-intensive areas.

### 32.3.7 Design

- 32.3.7.1 Softscapes are generally preferred to hardscapes.
- 32.3.7.2 Plantings adjacent to curb cuts at the entrance or exit of roadways, parking lots and pedestrian areas, shall be designed to provide clear visibility for persons leaving or entering the vehicular way.
- 32.3.7.3 Street trees shall be kept at a minimum of 10' from the curb.
- 32.3.7.4 No plantings shall have the center of the root ball within 10' of the exterior wall of any building.
- 32.3.7.5 The ground level surface for the entire perimeter of all buildings shall have minimum of a 4" thick layer of hard-pack clay, within a 5' band around the walls with a minimum of 6" of fall within the first 4' of the building.
- 32.3.7.6 Plantings and other landscape features shall take into account the maximum expected canopy and be designed not to extend within 5' of any exterior building walls.
- 32.3.7.7 Plants shall not block or cover building windows, security lighting, site lighting or access to any utilities.
- 32.3.7.8 When used, river-run gravel shall be 5/8" maximum size diameter, installed to a minimum thickness of 2", with an approved landscape barrier underneath.
- 32.3.7.9 No river rock or other projectile-type material(s) shall be used.
- 32.3.7.10 Retaining walls shall be incorporated into other design features; e.g. stairs, ramps, planters, etc.
- 32.3.7.11 Tree grates shall be steel type, not cast iron and in compliance with applicable ADA standards.
- 32.3.7.12 Tree canopies that project into accessible sidewalks and other designated egress path areas shall have no limbs within an 8' height above any part of the accessible route, at any stage of the life of the tree.
- 32.3.7.13 Tree wells located in sidewalks shall have the top of their root ball at the sidewalk surface.
- 32.3.7.14 See Appendix for bioretention pond requirements.

## DIVISION 32 – EXTERIOR IMPROVEMENTS

### 32.3.8 Plant Types to Avoid

- 32.3.8.1 Plants having invasive surface root system near underground utilities, building foundations and lawn areas
- 32.3.8.2 Plants unduly prone to disease; e.g. Birch, Elm, etc.
- 32.3.8.3 Plants with incompatible water requirements from existing landscaped areas
- 32.3.8.4 Plants particularly active in fruit, pollen or leaf fall
- 32.3.8.5 Plants known to have particularly brittle structures; e.g. Bradford Pears, etc.

### (32.7) IRRIGATION

#### 32.4.1 General

- 32.4.1.1 JMU prefers to have Toro Irrigation products.
- 32.4.1.2 JMU shall be responsible for temporary service if system should be down for repairs, etc. JMU will need to know immediately if service will be interrupted for greater than six (6) hours.
- 32.4.1.3 Newly installed systems are required to have a Toro TFS series flow sensor installed.
- 32.4.1.4 All irrigation systems shall be installed with an approved RPZ backflow preventer installed by a licensed plumbing contractor. (see Plumbing section)
- 32.4.1.5 All fittings installed shall be sch40 PVC pressure rated fittings unless otherwise specified. When using female adapters the fitting should be sch80 PVC with a metal reinforcement ring. All male adapters installed shall be sch80 PVC.

#### 32.4.2 Winterization

- 32.4.2.1 Contractor is to provide the initial startup, first winterization and first spring start-up.
- 32.4.2.2 All systems installed shall be fitted with an interior winterization connection where practicable. At no time shall this connection be more than 5' from the building and located in the main valve box.
- 32.4.2.3 Provide a 1" connection for an air compressor after the main shutoff valve at the winterization blowout.

#### 32.4.3 Piping

- 32.4.3.1 All sch40 pipe shall meet ASTM D-1785. When installed, the piping should be sized so that velocity shall never exceed 5 feet per second.
- 32.4.3.2 Gasketed piping is allowed as long as proper thrust blocking is provided.
- 32.4.3.3 1/2", 3/4", and 1 1/4" pipe and fittings are not to be used without prior approval.
- 32.4.3.4 Flexible pipe attached to lawn and landscape sprinkler heads shall be no less than 12" and not to exceed 2' in length.

#### 32.4.4 Pipe Installation

- 32.4.4.1 Non-winterized portions of the irrigation water main shall be buried to a minimum depth of 36".
- 32.4.4.2 A minimum of 2" horizontally is required between pipes in the same trench.
- 32.4.4.3 Pipes 3" and larger require thrust blocking. Thrust blocks are to be anywhere that the pipe changes directions, sizes, valves and terminations.
- 32.4.4.4 No trenching is permitted inside the drip line of trees.
- 32.4.4.5 All PVC piping shall have a tracer wire installed 14-gauge or larger. The recommended color for tracer wire is green.

#### 32.4.5 Valve Boxes

- 32.4.5.1 A standard valve box shall be used on 1" systems and a jumbo valve box shall be used on systems 1.5" and greater.
- 32.4.5.2 Heavy duty full-port brass ball valve for systems with 2" or smaller main line and a cast iron gate valve on systems 2.5" and larger. The valve shall be sized the same as the mainline.

## DIVISION 32 – EXTERIOR IMPROVEMENTS

- 32.4.5.3 Valve boxes shall be supported by bricks, with their tops set flush to finished grade before backfilling.
- 32.4.5.4 No more than two 1" valves per box. Valves 1 ½" and larger limited to one per box.
- 32.4.5.5 Wire splicing shall be in a 10" round box unless the splicing takes place at a valve manifold.
- 32.4.5.6 Valve boxes are to have green lid in turf areas and a brown lid in mulched landscape areas. Valve boxes located three feet or less from paved surface to be traffic rated unless otherwise approved by JMU.

### 32.4.6 Valves

- 32.4.6.1 All electric valves shall be Toro P-220 with the "Ez-Reg" pressure regulator.
- 32.4.6.2 A ball valve is required before each valve manifold to assist in repairs.
- 32.4.6.3 The ball valve shall be schedule 80 PVC or heavy duty brass.
- 32.4.6.4 A minimum of 6" of pipe is required before the ball valve and 6" after the electric valve that does not contain any fittings.

### 32.4.7 Sleeving

- 32.4.7.1 Sleeves shall be installed anywhere pipe or wire crosses under pavement, sidewalks or other finished areas. This sleeve shall be a minimum of 4" in diameter, or twice the size of the piping served.
- 32.4.7.2 Sleeves dedicated for future use shall be installed in under roads and at the specific request of JMU.
- 32.4.7.3 All sleeves shall be schedule 80 PVC.

### 32.4.8 Heads

- 32.4.8.1 Spray heads shall be 6" for lawn areas and 12" in landscape beds.
- 32.4.8.2 All sports fields' heads shall be on 1" sch40 swing joints.
- 32.4.8.3 Backfill material surrounding sprinkler heads shall be permeable same or light pea gravel to discourage ponding around sprinkler head. Sprinkler head shall be installed to the proper grade and shall be hand compacted only.
- 32.4.8.4 Heads installed along paved surface to be no less than 4" from edge. The head shall be vertical and set to grade.

#### 32.4.8.5 Approved Fixed Heads:

- ⇒ Toro 570Z series with check valve and Toro Precision nozzle.
- ⇒ Hunter Pro-Spray PRS40 with check valve and Toro Precision.
- ⇒ Rainbird 1800 SAM-PRS series with check valve and Toro Precision nozzle.

#### 32.4.8.6 Approved Rotating Heads:

##### Lawn and Landscape

- ⇒ Toro Super 800 w/check
- ⇒ K-Rain Super Pro w/check
- ⇒ Hunter PGP Ultra w/check
- ⇒ Rainbird 5000 Series w/check

##### Sports Fields

- ⇒ Toro T7 Stainless Steel
- ⇒ Hunter I-40 Stainless Steel
- ⇒ K-Rain ProSport Stainless Steel

## DIVISION 32 – EXTERIOR IMPROVEMENTS

- ⇒ Rainbird 8005 Stainless Steel
- ⇒ Toro 2001 Stainless Steel (Limited Availability)

### 32.4.9 Controller

- 32.4.9.1 Irrigation control shall be provided by a Toro Sentinel controller. Irrigation controller shall be installed by a contractor. Controllers shall be installed indoors in a stainless steel cabinet. JMU will decide whether or not the controller is to have a faceplate.
- 32.4.9.2 All circuits to be in ¾" conduit from outside building to control panel at central location.

### 32.4.10 Electrical

- 32.4.10.1 All exterior wiring shall be in an approved electrical PVC conduit.
- 32.4.10.2 All electrical splices to be in 3M direct burial splice kits.
- 32.4.10.3 All irrigation wire shall be 18-gauge for multi-strand wire and 12 or 14 gauge depending on length for 2-wire systems.
- 32.4.10.4 Systems with less than 10 zones shall be multi-strand. The white wire shall be the common. With multi-strand systems, two wires need to be left unused for future additions. The extra wires are to be labeled in the controller and not wired to anything. The ends of the wires are also to be labeled.
- 32.4.10.5 Systems with greater than 11 zones shall be Toro 2-wire.
- 32.4.10.6 Wire splices at electrical valves shall be made only with approved device listed within these specifications. Wherever a splice occurs it shall be accessible through an approved valve box. At any splice or valve box there should be a minimum of 24" of coiled wire 1" in diameter for slack in future repairs and surge protection.
- 32.4.10.7 All PVC piping shall have a tracer wire installed so that it can be located in the future. The tracer wire shall be 14-gauge or larger in size. The recommended color for tracer wire is green. A connection point shall be left at each valve box to aid in future irrigation locating.

### 32.4.11 Mapping

- 32.4.11.1 Contractor to provide a fully detailed "as-built" irrigation map of all piping, valves, vaults and all other irrigation system components to JMU within 30 days of project completion.
- 32.4.11.2 All irrigation valve circuits shall be colored and numbered to correspond to zones on irrigation map.
- 32.4.11.3 All maps shall include detailed measurements from as many reference points as necessary to determine all component locations.

### 32.4.12 Inspections

- 32.4.12.1 All piping shall be visually inspected for leaks after installation.
- 32.4.12.2 Mainlines and laterals shall be pressure tested to maximum working pressure and held at that pressure for one hour.
- 32.4.12.3 The entire irrigation system is to be guaranteed free from leaks for at least one year after installation. Any leakage occurring during this one year period shall be corrected by the contractor, at their expense.
- 32.4.12.4 The entire irrigation system shall be in working order for final inspection.

## DIVISION 32 – EXTERIOR IMPROVEMENTS

**32.4.12.5** Final inspection shall be performed by JMU’s irrigation technician. The contractor shall be on-site for this inspection and shall provide the “as-built” drawings at that time.

### **32.4.13 Repairs**

**32.4.13.1** All repairs are to be made with like materials.

**32.4.13.2** Repairs shall be guaranteed to be free from defects for one year.

**(33.1) UTILITIES LOCATING & TRACER WIRE**

**33.1.1 Utilities Locating**

- 33.1.1.1** Both locally owned and university owned utilities exist on the JMU campus. The excavating contractor shall call VA 811 at 800-552-7001 at least 48 hours, excluding Saturdays, Sundays, and legal State and National Holidays, before excavation or demolition begins, or as required by VA 811.
- 33.1.1.2** Contractor shall mark the limits of excavation with white paint or white flags prior to contacting VA 811.
- 33.1.1.3** Once VA 811 has cleared the ticket, it is the responsibility of the contractor to call VA 811 to get utility markings refreshed.
- 33.1.1.4** All digging within 2 feet of paint marks shall be done by hand or other soft digging methods. The damage to any encountered utilities shall be cause for immediate contact of the JMU Geospatial Engineering Services Department and a stop-work on all excavations.
- 33.1.1.5** The contractor shall be fully responsible for any and all resulting damages within the VA 811 marked lines for the entire excavation process. Damages repaired by JMU will be billed to the contractor at cost plus 20%.

**33.1.2 Tracer Wire**

- 33.1.2.1** Tracer wires shall be installed on all underground utilities and brought to the surface at terminations points in approved access boxes no more than 500' apart. Except on Irrigation lines. On irrigation lines a 10" round box or an Irrigation Valve box shall be installed at each pipe intersection and the tracer while should be accessible in the box for each pipe. Whether Utilities are installed by open trench, horizontal directional drilling, or pipe bursting. Tracer wire shall be installed along the full length of the utility and placed directly on top of the utility.
- 33.1.2.2** Tracer wire is not to be looped or coiled at any point along the utility.
- 33.1.2.3** Tracer wire shall be a water blocking utility locating system with a woven polyester water blocking yarns encapsulated in a 30 mil, HDPE jacket providing corrosion resistance, flexibility, impact strength and 1800 lbs. tensile strength.
- 33.1.2.4** All tracer wire systems must be designed and installed to last the lifetime of the utility it accompanies.
- 33.1.2.5** Tracer wire must be color coded according to American Public Works Association (APWA) color
- 33.1.2.6** Tracer wire is to be grounded at all termination points and access boxes. The ground wire should be accessible within 3" of the top of the lid in access boxes.
- 33.1.2.7** Tracer wire and ground rods must be accessible and protected in an access box.
- 33.1.2.8** Traffic rated access box to be placed in vehicular travel ways.
- 33.1.2.9** The tracer wire shall be grounded by use of a drive-in magnesium-grounding rod with a 10 gauge copper clad wire connected to ground rod and locate clip with a watertight cap. The ground Rod Shall be placed 90 degrees opposite the tracer wire at all dead ends stubs.
- 33.1.2.10** All connections, splices, and repairs shall be made with water blocking gel filled polycarbonate, 10-19 AWG connectors. When splices and lateral connections are made, only gel filled connectors designed for wire with a woven polyester fiber core are to be used and installed per the manufactures instructions.

- 33.1.2.11** Directional Drill Logs shall be provided for the as-built locations of tracer wire.
- 33.1.2.12** Access boxes shall be installed a minimum of 500 ft apart and 12 inches horizontal distance from the appurtenance. Except on Irrigation lines. On irrigation lines a 10" round box or an Irrigation Valve box shall be installed at each pipe intersection and the tracer while should be accessible in the box for each pipe.
- 33.1.2.13** Access boxes shall have the utility identification on the lid.
- 33.1.2.14** Tracer wire should extend a minimum of 18 inches above the top of the access box.
- 33.1.2.15** Access box lids shall be painted per APWA code
- 33.1.2.16** As-built drawings shall show tracer wire locations, access boxes and splice locations  
To insure Continuity and traceability the tracer wire shall be tested by the owner after installation completion. If tracer wire fails to function during testing, contractor must repair tracer wire before utility is accepted.

## APPENDIX A – DESIGN GUIDELINE CHECKLIST

### Site Design

- All site edges shall be designed and/or evaluated. Every completed project site must complement it's adjacent surroundings. Repair of site areas disturbed by the work of the project is not to be excluded from any project.
- Building placement must comply with all applicable master plans, design reviews, fire and service accessibility requirements.
- Building placement must connect to adjacent building pedestrian circulation and/or public way.
- All facility design must be fully functional within the project itself; all infrastructure and delivery of utilities or services must be included as an integral part of the project.
- All exterior drainage must drain away from structures, facilities, and hardscape areas. Drainage shall not flow across sidewalks. Sheetting, ponding, or sedimentation at building entries, walkways, bicycle paths, and other hardscape areas is unacceptable.
- Landscape maintenance must be considered in the site design. Planted areas whether grass, shrubs or trees must have accessible water. Verify locations and quantities of such infrastructure with JMU PM on a project by project basis.
- All loading docks, mechanical equipment, and other utilitarian areas shall be designed to fit within the campus context. Screening shall be included in the design of any such element. Landscape materials, fencing, and other screening materials shall be specifically approved by the Director of Facilities Planning and Construction.
- Each project site shall be provided with a project sign identifying the project name, scope, etc. This sign shall be the only construction sign permitted. Content shall be specifically authorized by the Director of Facilities Planning & Construction.
- Staging areas shall be specifically indicated on the plans. Limitations and requirements shall be specifically defined in the project manual. Requirements for the submission of traffic control plans by the Contractor shall be clearly defined by the consultant and confirmed by the JMU PM. JMU PM shall coordinate all access restrictions with campus entities effected.
- The consultant shall identify to the JMU PM all project impacts on University facilities and services whether direct or indirect. JMU PM shall coordinate all such events with the impacted university entity.
- Adjacent access and traffic paths shall be protected, as well as the protection of adjacent functions and/or facilities from noise, dust or disruption of services.
- All sidewalks shall be minimum 8 feet wide and six inches thick with sufficient reinforcing to support delivery and fire truck use.
- Adequate fire lanes and fire suppression equipment access shall be provided for each building. This requires a minimum of twelve feet width, eighteen feet where turns are involved.
- Construction fences enclosing sites shall be installed in locations indicated on the drawings. Extent of construction site shall be specifically approved by JMU, with full definition of the protection of adjacent uses and traffic. No barbed wire is allowed. All gates shall be double locked using contractor and university padlocks.
- Parking lots shall have type A (curb and gutter) curbs unless specifically approved.

## APPENDIX A – DESIGN GUIDELINE CHECKLIST

- Parking stalls shall be nine feet wide and eighteen feet deep minimum.
- Parking lot design shall provide for and identify immediately adjacent snow storage area equal to 15% of the entire parking lot area.
- DEB requirement for ADA parking within 25 feet of the building entry must be met.
- Hardscape areas must have a minimum ¼" per foot slope for drainage.
- Plant types and locations must be specifically approved by FM Grounds.
- Four inch capped conduits with pull strings shall be installed under all new sidewalks eighteen inches deep at 100 foot intervals. Marking/locator tapes shall be installed above conduit.
- Walkways or plazas utilizing pavers shall be fully supported by a reinforced concrete base. The edges shall be held in place by integral concrete curbs matching the height and width of the pavers.
- Install standard CG-2 concrete curbs along all access roads and fire lanes.
- Site and foundation design shall include geotechnical engineering of the site. For deep foundations and multiple floor structures A/E services shall include accomplishment and analysis of core drilling, electrical resistivity testing, seismic testing and other appropriate types of on-site investigation.

### Landscaping

- The landscape design shall be an integral component of any project. It shall respect existing site attributes and respond to its surroundings. Site design must provide adequate access, egress, views and noise buffers.
- The landscape vocabulary must be compatible with the University campus-wide elements such as plant materials, canopies, portals, covered walkways, passageways, shaded areas, and hardscapes. Softscapes are generally preferred to hardscapes.
- JMU PM shall verify that the design incorporates adequate resources for maintenance, i.e. water sources, power, etc., at all new or modified landscape areas.
- All buildings shall be equipped with exterior automatic freeze-proof key operated wall hydrants no more than fifty feet apart.

### Signage

- There is a need on campus to provide a holistic approach to signage. Exterior and interior signage should be designed from the existing vocabulary. JMU to review and approve any signage prior to fabrication.
- Room Identification signs will be included in the design, but provided by the University. Area and use identification as well as building directories shall be included in the design and provided by the contractor.

## APPENDIX A – DESIGN GUIDELINE CHECKLIST

**Acoustical Privacy** - These guidelines apply to all rooms requiring acoustical protection and/or isolation. A/E's are required to analyze designs on a project specific basis to determine where these or more stringent parameters apply.

- All plumbing penetrations in walls must be caulked airtight with acoustical caulk.
- Where recessed fixtures of any type are installed (e.g. medicine cabinets, fire extinguisher cabinets, electric panels, drinking fountains, bookcases, etc.) the A/E must ensure that the required acoustical isolation extends behind these elements.
- Installation of noise-generating devices (telephones, vending machines, etc.) should be avoided on the outside face of wall for any room requiring acoustical privacy. Such devices must also not be located in common hallway or corridor areas adjacent to noise sensitive areas.
- Locate doors to room requiring acoustical protection so that neighboring rooms do not have adjoining doors or openings on opposite sides of corridors facing each other. Such sensitive doors should also not be located opposite stairways, elevator lobbies, or restrooms.
- Do not locate restrooms or lounges directly over rooms requiring acoustical protection, stack restrooms whenever possible.
- Separate studs, with a structural in-wall air gap, must isolate the jambs of heavily used corridor doors from any adjacent rooms requiring acoustical isolation.
- Mechanical equipment, piping, and conduit in spaces above, beside, or below rooms requiring acoustical isolation must be vibration isolated from walls, floors, and ceilings.
- Demising walls for general purpose instructional spaces should have a Sound Transmission Coefficient (STC) rating of 50, although higher ratings may be required depending upon the rooms proximity to noise generating spaces such as mechanical rooms, lobbies, shafts, elevators, restrooms, etc. Ceiling height and materials shall provide a Noise Reduction Coefficient (NRC) of 0.55 to 0.65.
- Back to back utility installations shall be avoided. Place these installations one stud spacing apart to avoid sound transmission.
- Walls at faculty and/or management level staff offices shall extend full height to structure with acoustical insulation and gypsum board on each side to achieve acoustic separation.

### Building Configuration

- Design massing and volumes to respect and respond to visually adjacent existing buildings.
- Minimize the ratio of surface area of wall and roofing to the gross building area as much as possible to reduce heat loss and/or gain.
- Design roofs to shed snow, ice and rain in a controlled manner away from the path of building occupants. All entries and exits must be protected from snow fall by their specific roof design, not by roof or entry level barriers.
- Orient primary entries and exits, mechanical intakes, and mechanical discharges with respect to prevailing weather patterns. Buffer all entries through the use of vestibules. Shield all

## APPENDIX A – DESIGN GUIDELINE CHECKLIST

mechanical entries from moisture, snow, or frost intrusion through the use of orientation and of plenums, freeze proof preheat coils, or other means.

- Locate all mechanical and equipment areas such that a clear defined path is maintained for removal and replacement of equipment. Provide all necessary structural and finish elements needed to allow for movement of associated devices and elements. A/E shall demonstrate in Preliminary and Working Documents the plan for removal and replacement of components. Rooftop equipment must be specifically authorized by JMU.
- All roofs shall be single-ply fully adhered EPDM or TPO membrane or clay tile unless specifically approved by JMU.
- All buildings shall be construction of maintenance free materials (i.e. brick, concrete masonry units, precast concrete) unless otherwise specifically approved by JMU.
- Building entry areas shall be hard surface, preferably terrazzo. Recessed mats shall not be used.
- Building entries shall utilize airlocks to minimize air and dust intrusion.

### Custodial Areas

- One custodial closet shall be provided per 10,000 s.f., per story, for every story in the building. If multiple closets required per story, closets shall be a minimum 300' between closets.
- Ideally custodial closets should be located near elevators, toilets, and centralized among the areas they will serve. Do not locate custodial closets on stair landings.
- Entrances to custodial closets through restrooms, mechanical rooms, or similar intermediate spaces or visa versa are not permitted.
- The typical custodial closet floor needs to be a minimum of eighty square feet (approximate dimensions 8' x 10') with a clear ceiling height of nine feet minimum.
- Do not locate components of any telecommunications, electrical or mechanical systems in custodial closets. Specifically, the following shall not be located inside custodial closets:
  - Desks
  - Telephone panels
  - Electrical panels or switchgear
  - Data distribution panels or equipment
  - Water heaters
  - Circulation pumps
  - Mechanical equipment
  - Roof hatches / access panels
  - A large capacity floor sink with hot and cold running water and a floor drain must be provided in each custodial closet. Sinks are best located near the door, and should be positioned so that cleaning machines and equipment can be maneuvered easily and emptied into the sink prior to being refilled.

## APPENDIX A – DESIGN GUIDELINE CHECKLIST

- Provide doors that open outwards. A three-foot wide single door is adequate except in cases where the closet is wide and relatively shallow in depth. In those cases double doors may be required.
- Provide shelving on three walls for a minimum of fifteen lineal feet with a minimum of fourteen inches clearance vertically between shelves. Mop hangers and racks for mops, hoses or brooms must also be provided.
- At least two 125 volt, 20 amp, GFI electrical duplex outlets are required in each custodial closet. Heavy duty protected lighting fixtures with occupancy sensor light control is mandatory. Lighting level design standard should be at least 50 to 75 maintained footcandles. When occupied adequate ventilation and exhaust are essential; provide a minimum of fifteen air changes per hour.
- Floors should be either quarry tile, ceramic tile, or sealed concrete. If sealed concrete floor shall be cleaned of all stains and dirt prior to sealing. Wall finishes should be lead-free ceramic tile or other impervious material up to fifty-four inches above finished floor. Semigloss or gloss epoxy paint is a minimum wall finish. A finish ceiling is not required, but exposed overhead shall be painted out in a light color acceptable to JMU.
- A large capacity Terrazzo floor sink with stainless steel rim, stainless steel splash protectors, hot, cold and tempered running water and a floor drain shall be provided in each custodial closet. Sinks are best located near the door, and should be positioned so that cleaning machines and equipment can be maneuvered easily and emptied into the sink prior to being refilled. 4' high FRP paneling wainscot minimum 4' each side of the centerline of the sink. Blocking shall be provided at the wall beside the floor sink for chemical dispenser.
- No return air shall be taken from custodial closets.
- In addition to the wet custodial closet a one hundred twenty square feet Custodial Supply Storage Room shall be provided for each building. This room should be located in proximity to the elevator.
- In addition to or incorporated in to the above, each facility shall be provided with a custodial staff area. This area shall include lockers, table and chairs, a sink, cabinetry and countertop, electrical outlets for countertop equipment, a bulletin board, and a wall clock. Size and location of the area shall be verified and confirmed by the project manager.
- Custodial areas shall be provided with hot and cold hose bibs.

### Equipment Rooms

- At each mechanical, electrical, elevator, substation, or penthouse equipment room provide at least one telephone and one data outlet with adjacent 125 volt GFI duplex outlet.
- All mechanical equipment rooms must have a 3 phase, 50 amp receptacle for welder's equipment.
- Cooling towers and chillers shall be located at ground level. They shall never be roof mounted or enclosed at midfloor levels.
- Transformers, boilers, chillers, and other large equipment shall be located to permit easy servicing, operation and removal. Equipment room layouts must indicate graphically how

## APPENDIX A – DESIGN GUIDELINE CHECKLIST

servicing, operation and repair clearances are assigned. This graphic representation(s) must include all necessary carrying beam/crane/pick point locations as well as equipment and personnel moving paths from the equipment location to the point of building egress. Clearly delineate all housekeeping pads. Similarly, roofing or roof mounted equipment servicing, maintenance, operation, and replacement clearances must be considered and graphically illustrated when designing both equipment and roof access.

- Provide adequate circulation around equipment, including valves and accessory piping. Access to equipment rooms must never be by means of ladders, ships ladders or alternating tread ladders. Access to and from equipment rooms must be clearly diagrammed on Preliminary drawings.
- Mechanical rooms and the equipment contained must be thermally, acoustically, and vibration isolated from adjacent spaces.
- Semigloss or gloss epoxy paint is a minimum wall finish. A finish ceiling is not required, but exposed overhead shall be painted out in a light color acceptable to JMU.
- All switchgear, main electrical panels, and subordinate electrical panels shall be located in electrical closets, not in public or programmed spaces.
- Where roof access by stairs is not a code requirement alternative solutions must be specifically approved by the Director of Facilities Planning & Construction. Access shall be provided without entrance through any other space, i.e. not through custodial, electrical, mechanical or programmed space. A preferred solution would be to have a stair, ships ladder, or ladder in a space specifically designed for that access.

### Maintenance Materials Storage Rooms

- Every new building or major remodel project must provide a maintenance materials storage room. This room shall be one hundred square feet (approximate dimensions 10' x 10') with nine feet clear ceiling. Each room shall have a three foot wide entry door.
- Locate the maintenance materials storage room near the service entry.
- Two 125 volt, 15 amp, GFI duplex outlets must be provided in the maintenance materials storage area.
- The maintenance storage room must have heavy duty protected lighting fixtures with occupancy sensor lighting controls.
- Semigloss or gloss epoxy paint is a minimum wall finish. A finish ceiling is not required, but exposed overhead shall be painted out in a light color acceptable to JMU. Sealed concrete is an acceptable floor finish provided that prior to sealing all stains and dirt are removed.

### Trash and Recycling Facilities

- A recycling room of approximately one hundred square feet (approximate dimensions 10' x 10') must be provided in each facility. This room must be located near the loading/service area.

## APPENDIX A – DESIGN GUIDELINE CHECKLIST

- All trash and recycling areas shall be sheltered from the wind, and easily accessible by custodial staff. Locations must consider the unpleasant odors often generated by these spaces.
- Trash collection, pick up, and disposal operations and vehicular accessibility must be carefully studied. Preliminary documents must diagram these considerations.
- Screen all trash collection locations with materials compatible with adjacent building materials.
- Provide a hose bib at all trash collection & handling areas.
- Provide integrated screened dumpster sites at all facilities.
- Semigloss or gloss epoxy paint is a minimum wall finish. A finish ceiling is not required, but exposed overhead shall be painted out in a light color acceptable to JMU. Sealed concrete is an acceptable floor finish provided that prior to sealing all stains and dirt are removed.
- Provide hot and cold hose bibs and floor drain.

### Loading/Unloading Areas

- All new or remodeled facilities shall be provided with off-street adequate service loading and unloading areas. The A/E shall quantify the scope and scale of loading capabilities required with the both the program and facilities management representatives.
- Loading facilities shall allow the use of multiple scales of delivery. Access shall be provided on grade or with ramps for hand truck or cart deliveries to the loading area. Loading docks shall be 34 inches above top of pavement.
- Interior and exterior staging, packaging, unpacking, and temporary storage areas for loading and unloading shall be included in the facilities.
- Access to and from the loading area must be clearly diagramed on the Preliminary Design Drawings.
- Semigloss or gloss epoxy paint is a minimum wall finish. A finish ceiling is not required, but exposed overhead shall be painted out in a light color acceptable to JMU. Sealed concrete is an acceptable floor finish provided that prior to sealing all stains and dirt are removed.

### Offices

- Faculty and managerial level staff office areas shall include space and services to allow current or future provision of an L-Shaped desk, a return, a three-foot lateral file and/or bookcase, and two guest chairs, and a four-foot square whiteboard. . Each office shall also have one wired pathway and one future pathway for , data, and video. All walls to receive markerboard must be constructed with appropriate blocking.
- Faculty and managerial level staff offices shall maintain a maximum allowable ambient noise level meeting or exceeding NC 30-35.

## APPENDIX A – DESIGN GUIDELINE CHECKLIST

- Non-managerial level offices shall be designed utilizing open office partition systems. Project manager shall confirm that the design incorporates all necessary provisions for acoustic privacy, i.e. background pink or white noise generation, acceptable panel NRC ratings, etc.

### Instructional Spaces (including Conference Rooms)

- All classroom furnishings, lighting fixture layouts, presentation equipment, and accessories must be clearly diagrammed in the Preliminary Documents.
- Lighting shall be designed to allow presentation on white boards, projection on screen with concurrent note taking, and fully lit classroom functions.
- Typical general purpose classroom equipment must include, but not be limited to, the following:
  - Instructor area desk and podium with computer connection, power, telephone connection, and video connection.
  - Chalkboards and/or markerboards
  - Tackable display surfaces
  - Student Seating, verify type and orientation on a room by room basis
  - Trash and recycling receptacles near the classroom door
  - Motorized retractable projection screen
  - Wall clock
  - Video and data outlets with adjacent power outlets, verify quantities and locations on a room by room basis
  - Ceiling mounted Data/video display unit, associated infrastructure and associated voice augmentation
  - General purpose electrical outlets for both operation and maintenance
- A certain number of instructional spaces (as a minimum one of each size in a given facility) must be provided with the distance learning equipment infrastructure. This infrastructure must include space availability, system capability, structural capacity and pathways for cameras, control/operation areas, monitors, projection devices, etc.
- Instructional spaces acoustical characteristics shall be as follows:
  - Walls – minimum of STC 50
  - Floor/Ceiling assemblies – STC 58 to 60
  - Ceilings – The surface of the ceiling must be designed to accommodate the required acoustical properties stipulated for each individual room. The area of the ceiling that should be covered with a .55 to .65 NRC rated acoustical tile is directly related to the ceiling height as follows:
    - Eight feet clearance: forty to fifty percent
    - Ten feet clearance: fifty to sixty percent
    - Twelve feet clearance: sixty to seventy percent
  - Mechanical system ambient noise level must meet or exceed NC 25 to NC 30.

## APPENDIX A – DESIGN GUIDELINE CHECKLIST

- Reverberation must be controlled by applying acoustical material to walls as necessary. This application must be integrated with the overall space design rather than simply applied as an afterthought.

### Restrooms

- Direct or reflected line of sight into restroom shall be broken.
- No return air shall be taken from restrooms.
- Lighting shall be provided above all enclosed stalls.
- All wall mounted fixtures and accessories shall have adequate backing. Some rooms may require full plywood backing behind sheetrock. Verify each room's specific requirements with the project manager.
- Provide lead free ceramic tile wall or wainscots fifty-four inches high minimum with epoxy paint finish above at all restrooms.
- All lavatories shall be ceramic. Steel lavatories with enamel finish are not allowed.
- Floors shall be lead-free ceramic tile with unglazed, sealed, lead-free integral dark grout.
- Locations of ALL restroom accessories must be shown on the documents regardless of whether or not they are part of the construction contract.
- All shower surrounds and toilet partitions must be fully detailed, providing clear definition of the fabrication and installation quality required. All toilet partitions shall be solid plastic.
- Restrooms and bathrooms shall be constructed with watertight floor/wall systems with integral floor drains. Floor drains shall be equipped with passive self-priming devices.
- Provide floor mounted toilet fixtures unless specifically approved by the university.
- Provide one 125 volt, 15 amp GFI duplex outlets located adjacent to the lavatory in each restroom.

### Lobbies

- Access to buildings shall be through central, enclosed, lockable lobby areas.
- Provide a vestibule at all building main level entries unless otherwise indicated in the detailed project program. All vestibules must have walk off carpet, for the full extent of the vestibule, as approved by Facilities Management through the project manager.
- The building lobby shall contain a building directory, a lockable bulletin board and provision for the installation of two telephones.
- Provide terrazzo flooring at all lobbies unless otherwise specifically authorized.
- Entrance doors shall be recessed or protected by canopies or wing walls.
- Servicing and/or replacement of all lighting in lobbies, atriums, and other high ceiling, high volume spaces, must be carefully studied in Preliminary Design. The placement of any and all fixtures which require periodic or sporadic servicing and/or maintenance must be specifically authorized. It is mandatory that the A/E itemize and identify all such elements in the Preliminary Design submittal.

## APPENDIX A – DESIGN GUIDELINE CHECKLIST

### Safety

- Notify the University's Department of Public Safety of any anticipated or actual hazardous waste generated by the project.
- Material Safety Data Sheets (MSDS) for all materials used in the project are an essential part of the required project closeout documents to be provided to the University.
- Areas of rescue assistance and elevator emergency telephones must be designed to be fully compatible with the University emergency telecommunication system. Each shall be equipped with an emergency telephone which connects at the push of a single button with the campus police station, identifying its specific individual location and allowing direct interactive voice communication through the existing campus telephone system. These elements and systems are NOT to be vendor or contractor designed through the submittal process. A full and complete design is required from the A/E.

**Security** – In general there are three levels of security for most campus facilities although in some special cases a fourth level may be required.

- 1) Level One for Public and Semi-Public Spaces – This level applies to public spaces with intense traffic and no clear ownership definition. Among public spaces are lobbies, unrestricted public corridors, vestibules, classrooms, stairs, elevators, public restrooms, food service facilities, bookstores, recreation facilities, parking facilities, etc. Examples of semi-public spaces include reception areas, seminar rooms, libraries/resource centers, theaters, lecture halls, auditoriums, study areas and conference rooms. The following security measures are recommended for public and semi-public spaces:
  - Clearly defined hours of use
  - Well lighted entries, lobbies, & corridors
  - A view into spaces before entering
  - Doors lockable only by maintenance staff or university police
  - Visibility from adjacent occupied spaces
  - Emergency telephones linked to university police
  - Easily identifiable and accessible exit routes
  - Fire/smoke alarm system
  
- 2) Level Two for Private and Locked Semi-Public Spaces – Parts of a facility may be secured by locked doors. In those areas traffic flow is smaller and controlled, and more valuable equipment and/or risk factors are involved. Examples of private spaces at this level include faculty & staff offices, teaching labs, exercise facilities, health and safety areas, lecture hall preparation areas, projection booths, dark rooms, private toilets, special collection areas, campus operation and maintenance spaces, building mechanical/electrical/telecommunication spaces, etc. In addition to the security measures recommended for Level One, these areas should included the following:

## APPENDIX A – DESIGN GUIDELINE CHECKLIST

- Secured doors with inside vandal-proof or pinned hinges and latch guard
- Lockable windows
- Controlled/programmable keying system
- Non-lift sliding windows or doors (if used)

3) Level Three for Secure Spaces – Among these are high value equipment holding spaces, special collection areas, high value exhibit spaces, supply rooms, computer mainframe rooms, special secured areas, confidential file rooms, vaults, etc. The security requirements for these spaces must be determined on a case by case basis, but as a general rule of thumb the following may be considered in addition to all the security features noted for Levels One and Two:

- Motion sensors
- Intrusion alarms
- Electronic surveillance
- Time clock access restrictions
- Security guard/patrol intervals
- Special ID detection/access systems

Exterior Security – The protection of people and vehicles at building exteriors is extremely important. Security at walkways, entries, loading and unloading areas, near ground floor windows, and at building indentations can be significantly enhanced by applying the same principles followed in the design of other public spaces.

- Exterior illumination should never be below one footcandle and all plantings which might serve as a hideaway must be kept below three feet in height or above six feet clear trunk with a clear visibility zone between them. All exterior lighting should be vandal-resistant, and where possible directed downwards.
- All elevators shall have the capability of being key operated after regular working hours.
- At all new or remodeled buildings install a two inch empty conduit from building telecommunications room to telecommunications room and a one half inch empty conduit from each building entry to the telecommunications room for future connection of a security and/or card access system. All necessary power and signal infrastructure shall be provided for future installation of electric strikes, card readers, resultant emergency exiting devices, etc.
- All latchsets, locksets, locks, door hardware and accessories shall comply with the JMU lock shop standards. JMU PM shall coordinate all related design elements with the lock shop.

### Stairs

- All stairway light fixtures must be accessible from landings using a six foot (maximum) ladder.

## APPENDIX A – DESIGN GUIDELINE CHECKLIST

- All exit stairs must have hard surface floor coverings. Terrazzo floors shall be used at main stairways. Terrazzo is preferred for secondary stairs, but rubber tread covers with integral risers, stringer skirts, and rubber flooring at landings will be considered.
- Provide one 125 volt, 15 amp GFI duplex outlet at each stairway floor level landing.

### Overhead Glazing

- Overhead glazing shall be vertical monitor or clerestory. Skylights are not desired and must be specifically authorized by the Director of Facilities Planning & Construction.
- Where overhead glazing is designed, an acceptable method for maintaining and cleaning must be included as part of the Preliminary Design submittal.

### Public Corridors

- All corridors must have 125 volt, 15 amp GFI duplex outlets located no farther apart than eighty feet from each other.
- A/E must verify and include the quantity, type, and sizes of all programmatically required display cases, cabinets, or bulletin boards located in public spaces.
- No vending machines shall be located in main public corridors. Where vending machines are authorized A/E shall design all appropriate power, water, drain and telephone/data connections.
- Provide terrazzo flooring at all main corridors unless otherwise specifically authorized.

### Lighting

- Lighting types and levels shall comply with Professional Services and Construction Manual and JMU Facilities Management directives. Project Manager shall review and coordinate these requirements.
- No ceiling mounted or supported light fixture shall be less than eight feet above finish floor.
- In preliminary design the ability to repair, relamp, and replace light fixtures of each type and at each installation condition shall be demonstrated to the satisfaction of the university.

### Telecommunications

#### General –

A telecommunications wiring system at JMU may carry analog and/or digital signals for voice, data and video systems or a combination of these elements. Today's technology permits the use of selective conductor types:

## APPENDIX A – DESIGN GUIDELINE CHECKLIST

- "unshielded twisted pair" (UTP) wire to interconnect voice and many common data communications systems;
- "universal cabling system" (UCS) composed of both UTP and coaxial cable to interconnect voice, data and video communications
- multimode fiberoptic conductors
- single mode fiberoptic conductors
- coax cable

The general parameters for installations is the prudently cynical approach that the telecommunications infrastructure provided shall be designed and installed to the most stringent or restrictive requirements of the conductors listed above. In other words any pathway must be able to function for each of the above conductor types. All pathways shall be in conduit unless specifically waived by the University. Such exception shall only be granted with the full prior knowledge of the University administrative bodies having responsibility for the associated systems.

Infrastructure shall be designed and installed in a manner which enables the following operational patterns:

- Star Topology - The media is distributed only from designated frames within the system. This topology improves signal quality by limiting the number of connections.
- Cross-connects - Cross-connects provide the system with the flexibility to make changes to the voice and data service quickly and easily using jumper wires or modular jacks.
- Head End - The head end is comprised of the equipment necessary to control the video network and allows universal service changes to be made from one location.
- Universal Outlet - Universal outlets provide a standard interface that permits devices to connect to any service by changing the connection to the outlet and not the outlet itself. The connection to the universal outlet may be accomplished directly or by using adapters when necessary.
- Administrative System - The administrative system is used to record new installs, track moves and changes and maintain an inventory of telecommunications equipment. The use of this system will help minimize labor and material cost and assist in capacity monitoring.

Physical Telecommunications Pathways -

## APPENDIX A – DESIGN GUIDELINE CHECKLIST

This section contains the specifications for the physical telecommunications pathway within a building.

### Building Telecommunications Entrance –

- A minimum of two 4 inch conduits shall be provided as telecommunications pathways into a building. The conduits shall begin outside of the building at a manhole or utility tunnel specified by the university. The conduits shall terminate inside the building at the main distribution frame. Any conduits that are not planned for use prior to occupancy shall be capped at both ends.

Main Distribution Frame - The main distribution frame (MDF) is a space that serves as the central point for inter-floor and inter-building connections.

- There shall be one MDF per building.
- The MDF shall be located on the lowest floor practical. It shall be placed so that the MDF is not more than 295 actual cable feet from any work area outlet.
- The MDF shall be at least 200 square feet in size and have a minimal ceiling height of 8 feet.
- Exterior grade 3/4" plywood backboard shall be installed on all walls. This backing shall be painted with gray fire retardant paint of a type approved by the University. All installations upon the backboards shall be square, plumb, and in an organized manner segregating differing technologies or systems to the greatest degree possible.
- All ceilings, walls (except backboards) and floors shall be made non-porous with paint or commercial sealant in order to minimize dust. Only paints that contain water or mineral spirits are recommended. Turpentine or ethylene should not be used. Carpeting is not allowed.
- The temperature and humidity shall be controlled in accordance with the manufacturer's specifications for the equipment anticipated to be housed in the MDF. In general, temperature should be maintained between 50 and 85 degrees Fahrenheit. The room should be well ventilated and where possible maintain a humidity of less than 70% (non-condensing).
- Entry into the MDF shall be off a public corridor. Entry through any other space is permitted only with the specific approval of the Director of Facilities Planning & construction. The entry door to the MDF shall be lockable. This door should swing out wherever possible.
- Lights shall be protected fixtures switched with occupancy sensors. In addition to power requirements for programmed space use, there shall be a duplex work outlet located near the latch side of the entry door.
- Minimal program use power shall include two dedicated power circuits located in the MDF.

## APPENDIX A – DESIGN GUIDELINE CHECKLIST

- Each power circuit shall have at least two duplex outlets. The power circuits shall be 115 +/-10% VAC, 15 +/-1 amp and 60 +/-2Hz. If the building is equipped with a backup generator, there shall be a generator driven circuit in the MDF.
- In some buildings, major voice and data equipment beyond the norm may need to be installed in the MDF. In such special cases additional power shall be supplied in accordance with the specifications of the equipment manufacturer. Project Manager shall ensure that the consultant verifies and documents all planned equipment during the preliminary document phase.
- The MDF may also function as an intermediate distribution frame for the floor on which it resides.

Intermediate Distribution Frame - The intermediate distribution frame (IDF) is a space that serves as an interconnect between the building communications riser and the horizontal distribution path for a given floor.

- There shall be at least one IDF per floor. Each IDF serves the floor on which it physically resides.
- The IDF(s) shall be placed so that they are not more than 165 actual cable feet from the farthest work planned or potential area outlet box on the floor it serves.
- IDFs shall be stacked vertically directly above each other from floor to floor in the building.
- The IDF shall be a minimum of 40 square feet in area with a minimum horizontal dimension of 5 feet. A minimum vertical clearance is 8 feet. Finished ceilings are not desired.
- Exterior grade 3/4" plywood backboard shall be installed on all walls. This backing shall be painted with gray fire retardant paint of a type approved by the University. All installations upon the backboards shall be square, plumb, and in an organized manner segregating differing technologies or systems to the greatest degree possible.
- All ceilings, walls (except backboards) and floors shall be made non-porous with paint or commercial sealant in order to minimize dust. Only paints that contain water or mineral spirits are recommended. Turpentine or ethylene should not be used. Carpeting is not allowed.
- A finish ceiling is not required, but exposed overhead shall be painted out in a light color acceptable to JMU.
- The temperature and humidity shall be controlled in accordance with the manufacturer's specifications for the equipment anticipated to be housed in the IDF. In general, temperature should be maintained between 50 and 85 degrees Fahrenheit. The room should be well ventilated and where possible maintain a humidity of less than 70% (non-condensing).
- Entry into the IDF shall be off a public corridor. Entry through any other space is permitted only with the specific approval of the Director of Facilities Planning &

## APPENDIX A – DESIGN GUIDELINE CHECKLIST

construction. The entry door to the IDF shall be lockable. This door should swing out wherever possible.

- Lights shall be protected fixtures switched with occupancy sensors. In addition to power requirements for programmed space use, there shall be a duplex work outlet located near the latch side of the entry door.
- Minimal program use power shall include two dedicated power circuits located in the IDF. Each power circuit shall have at least two duplex outlets. The power circuits shall be 115 +/-10% VAC, 15 +/-1 amp and 60 +/-2Hz. If the building is equipped with a backup generator, there shall be a generator driven circuit in the IDF.
- In some buildings, major voice and data equipment beyond the norm may need to be installed in the IDF. In such special cases additional power shall be supplied in accordance with the specifications of the equipment manufacturer.
- Telecommunications Riser Pathway - Two 4" conduits shall connect the MDF to the first IDF and each IDF to the IDF above itself
- Grounding - A grounding bar shall be installed in the MDF and in each IDF. The grounding bars shall be electrically connected to each other and to the main electric ground for the building.
- Work Area - Each room of 150 square feet or less is considered to be a work area. For rooms larger than 150 square feet, a work area is considered to occur each 150 square feet within the room.
- Outlet Boxes - Two 4" x 4" flush mount outlet boxes shall be installed in each work area. The boxes shall be installed on opposite walls from each other. Box location shall be established in the Preliminary document phase by the University telecommunications department as agreed to by the planned space occupant. The Project Manager shall coordinate and confirm these activities. Each box shall be equipped with a plaster ring to accommodate the installation of a 2" x 4" faceplate.

### Horizontal Distribution System –

- Each outlet box shall be directly connected by a 1" conduit to the IDF located on the same floor.
- Exposed conduit is not desired and must be specifically approved by the Director of Facilities Planning & Construction.
- No conduit pathway shall contain any one bend greater than 90 degrees or cumulatively more than the equivalent of four 90 degree bends.
- Each conduit shall contain a pull string.
- No conduit run shall be greater than 165 feet from outlet to IDF termination. Pull boxes are discouraged and may only be installed with prior university approval.
- To accommodate future expansion, two additional 4" conduits shall be installed at each IDF. The conduits shall originate in the IDF, stub into the ceiling in the nearest hallway and be capped.

## APPENDIX A – DESIGN GUIDELINE CHECKLIST

- Raceways or Cable Trays - Raceways or cable trays are not desired. If extenuating circumstances do convince the University to specifically approve their use it is mandatory that the consultant design the system with extreme attention to access and operational requirements. In a vane similar to the requirements for documenting and affirming access to mechanical equipment, the consultant is required to ensure access and ability to remove, lay, and modify conductors throughout the cable tray system. The consultant will be required to obtain specific approval any adjacencies of light fixtures, ductwork, mechanical devices, fire sprinkler equipment, ceiling grids, exit lights, etc. which in the university's perspective impede or impact access to the cable tray or it's contents.

### Room Numbers

- Room numbers shall be established by the University at the beginning of the Preliminary phase. These numbers shall be developed by the University space planning departments and coordinated by the JMU PM.
- All mechanical device, telecom jack, electrical circuitry, and other identifiers shall utilize this common set of space numbers.
- Room numbers shall not be changed without specific authorization by the University.

### General

- Storm Water Management Plan included as approved by DCR
- Erosion & Sediment Control plan included as approved by DCR
- Environmental Impact Report approved by DEQ
- Exterior Renovation approved by Historic Resources
- Building approved by Art & Architectural Review Board
- Floodplain modifications approved by FEMA & DCR
- Fire Suppression Sprinkler design approved by Fire Marshal and/or DEB
- Fire Alarm design approved by Fire Marshal and/or DEB
- All masonry and stonework shall match visually adjacent in color, texture, bond, and scale. Blue limestone shall be obtained from sources ensuring the lack of rust, bleeding, staining and other post installation discoloration.
- Gutters and downfalls shall be copper. Downfalls must have an accessible cleanout at grade level.
- All masonry must have 20 year breathable sealer.
- Full vapor barriers must be provided in all enveloping building systems. Documents must detail intersections and terminations of vapor barrier and the system testing for acceptance.
- All wood doors must be solid core.
- Pivot hinges shall not be used without specific university approval.
- Floor mounted closers shall not be used without specific university approval.
- Overhead doors must be insulated, with steel protective layer at door interior.

## APPENDIX A – DESIGN GUIDELINE CHECKLIST

- Provide key locks on all accessible access doors.
- No wood windows are allowed on academic or administrative buildings.
- Windows in residence halls shall be operable and lockable.
- Window screens and window operators shall be of commercial grade. Physical samples shall be provided by the A/E for specific university approval.
- The University locksmith shall approve all locks and door hardware.

### Mechanical

- All buildings shall be heated and cooled. Residence halls will be designed so that heating and cooling systems do not operate simultaneously.
- All buildings shall be heated with steam from the University's central distribution system. If steam is not available, and with specific University approval, buildings shall be heated with two natural gas fired hot water boilers.
- Residence Halls shall be equipped with separate gas-fired domestic hot water heaters. Electric domestic hot water heaters may be used in administrative and academic building.
- Humidity control shall be provided in academic buildings.
- All building HVAC controls shall be interfaces with and remotely controllable by the University's building automation system.
- System capacities and the ability to expand to reflect projected changes in building use shall be included in the design. A/E shall specifically confirm system capacities with FM Engineering.
- Confirm specification content for pipe and device painting and labeling per JMU standards.
- Confirm full and specific compliance with JMU standards.

### Electrical

- All high voltage distribution system designs shall comply with Harrisonburg Electric Commission (HEC) standards and requirements. A/E shall coordinate transformer site, sizing and installation with HEC. Transformer location and size must also be specifically approved by the University.
- All buildings shall be equipped with an emergency electrical generator system that is powered by Number 2 fuel oil, propane or natural gas. This system shall support, at a minimum, emergency lighting and fire suppression systems. Battery inverter systems are not acceptable.
- System capacities and the ability to expand to reflect projected changes in building use shall be included in the design. A/E shall specifically confirm system capacities with FM Engineering.
- Magnetic contactors shall be used to control site and exterior lighting. Contactor shall have HOA feature and be controlled by a photoelectric switch.
- Site lighting must match visually adjacent devices. Bollard style lighting is not acceptable.
- Confirm full and specific compliance with JMU standards.

### Furnishings & Equipment

- All designs shall include a furnishings layout by the A/E. Furnishing indicated will be based upon a general definition approved by the university. Design shall include a tabulation of elements by room including description of element, components, manufacturer, etc. used as a basis for design. This shall be provided with Preliminary Design submittal and updated for each construction document submittal.
- All designs shall include provisions for power and telecom connectivity to furnishings and equipment from source to point of ultimate connection.
- Window fabric blinds shall be included for all exterior windows, unless specifically waived by the university.
- All designs shall include tabulations of all planned movable equipment, including the following information at a minimum:
  - Device model and manufacturer
  - Location
  - Power requirements
  - HVAC requirements
  - Whether provided by contractor or university

## APPENDIX B – CARD READER DETAILS

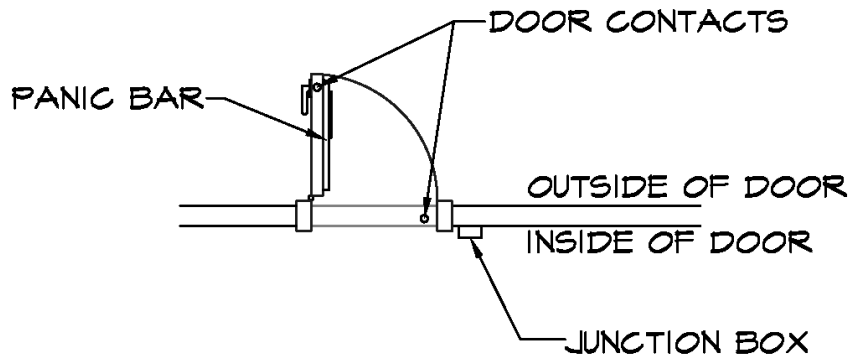
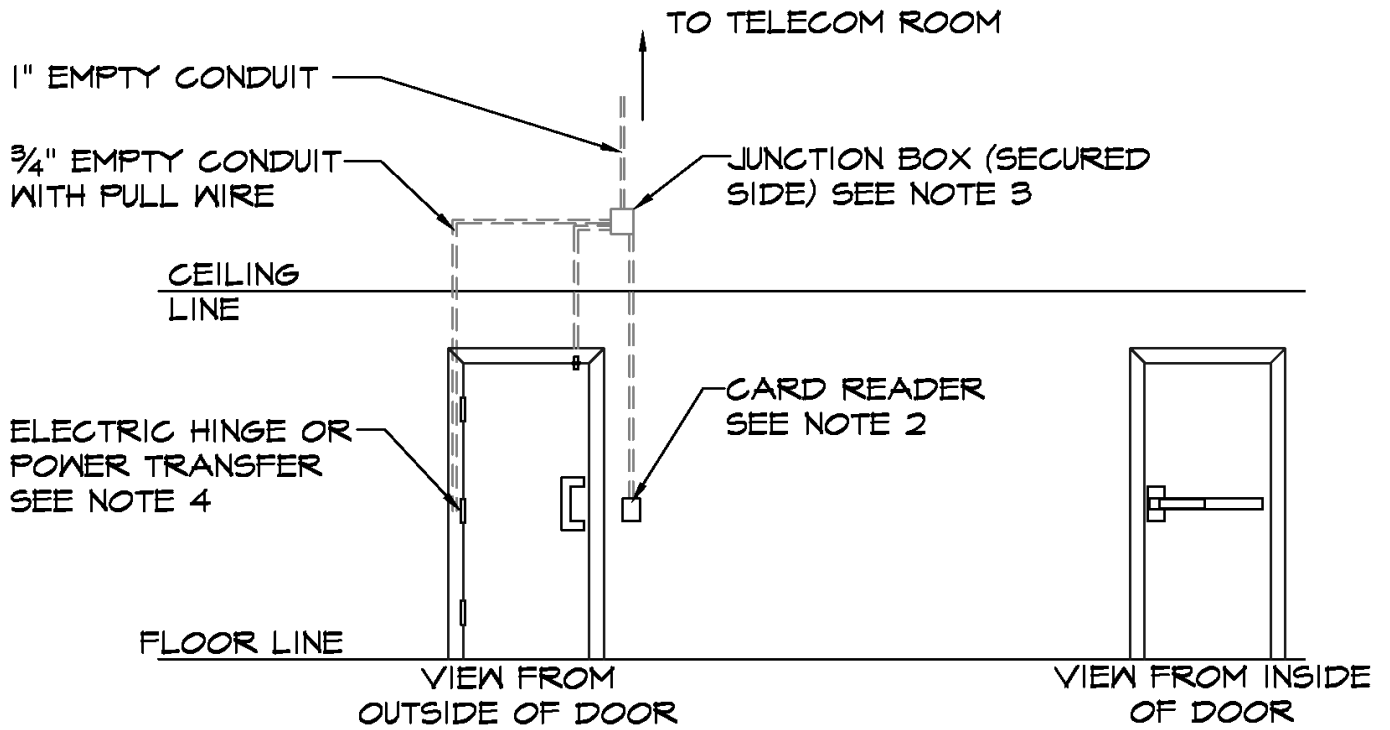

SINGLE CARD READER WITH  
PANIC HARDWARE  
SCALE 1/4" = 1'-0"

## APPENDIX B – CARD READER DETAILS

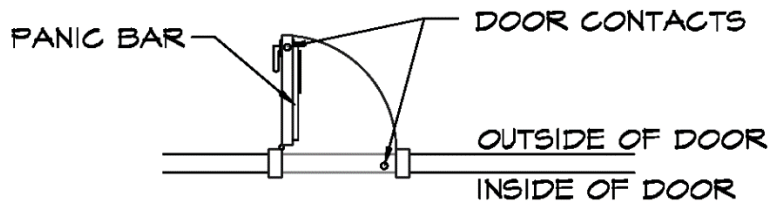
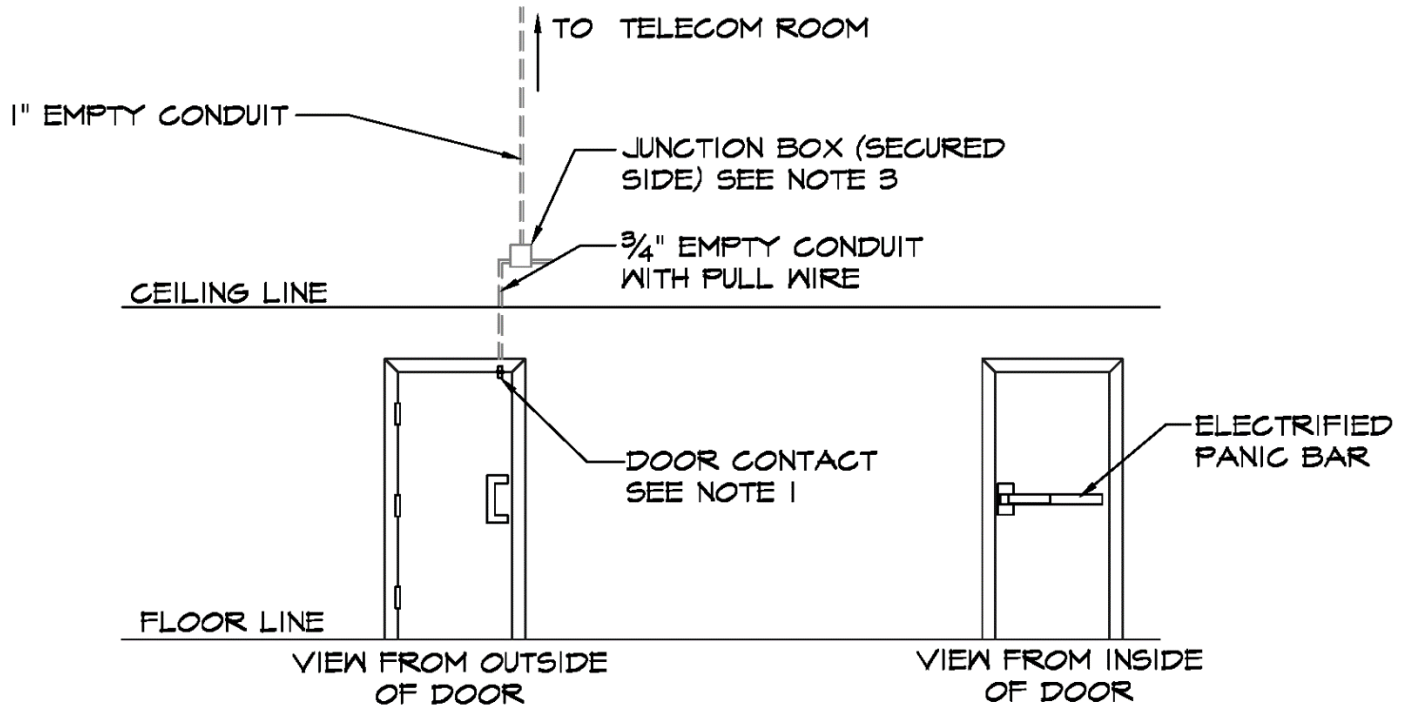

### SINGLE DOOR PROP DOOR ALARM

## APPENDIX B – CARD READER DETAILS

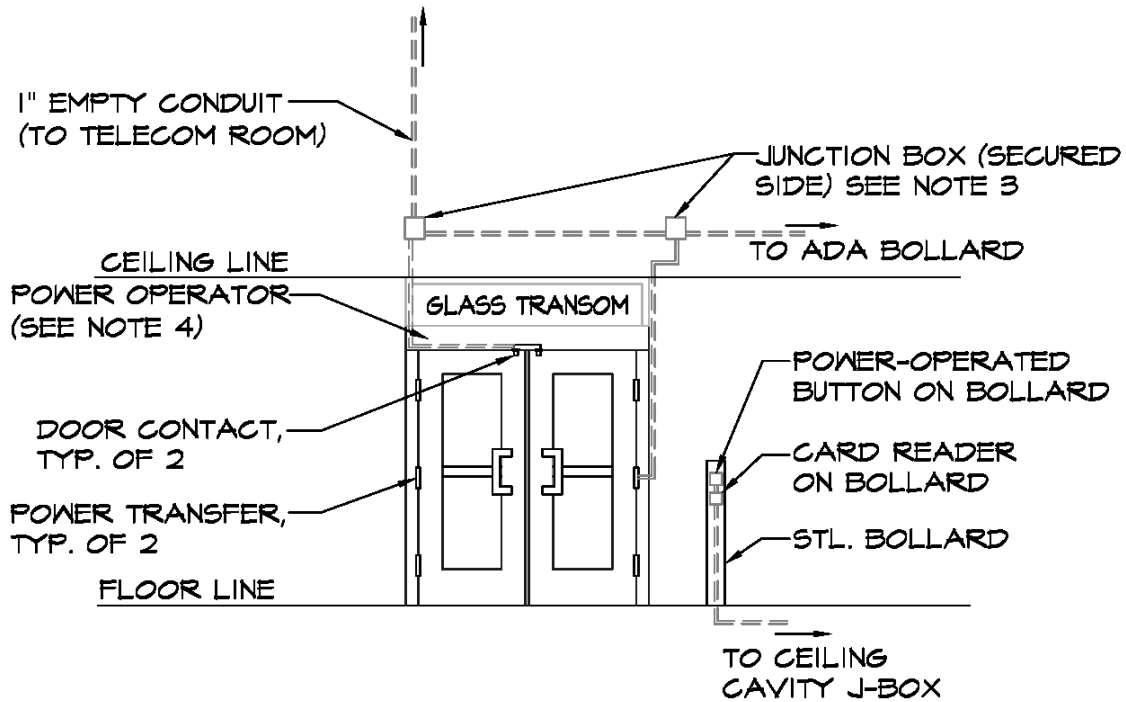

**CARD READER FOR HANDICAP DOOR**

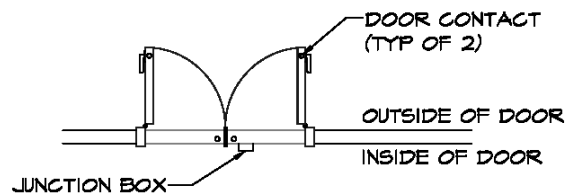
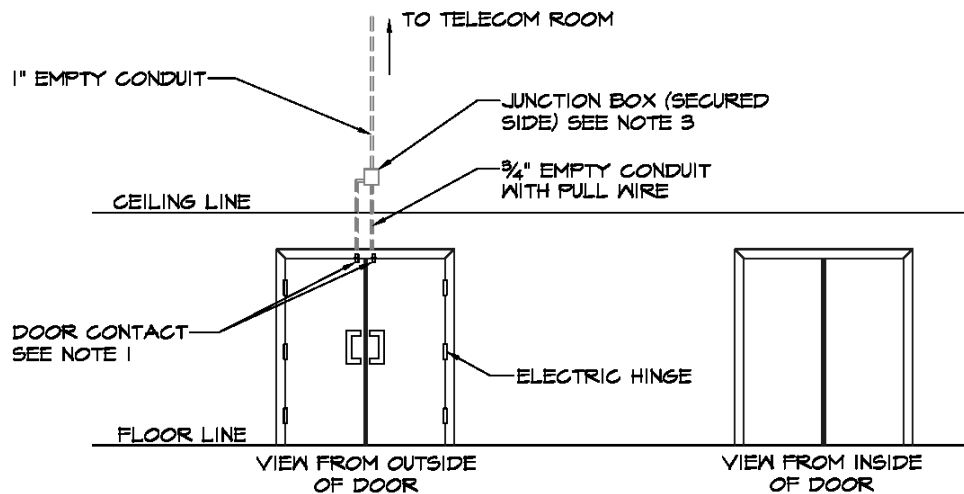

**DOUBLE DOOR PROP DOOR ALARM**

APPENDIX B – CARD READER DETAILS

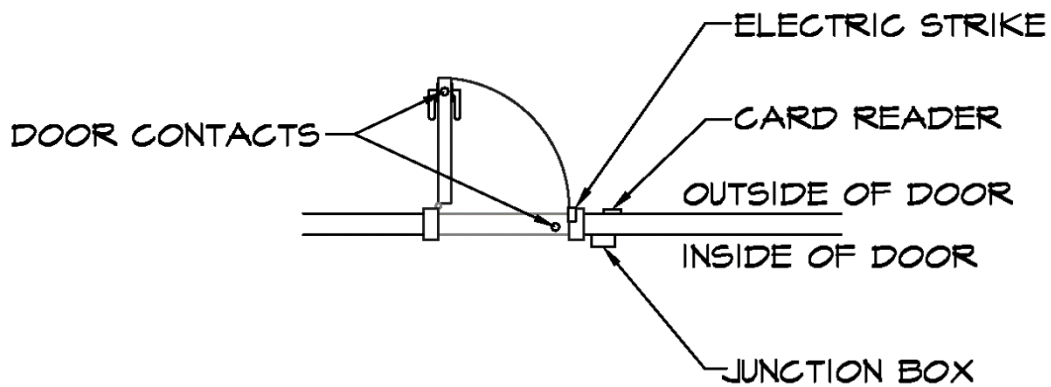
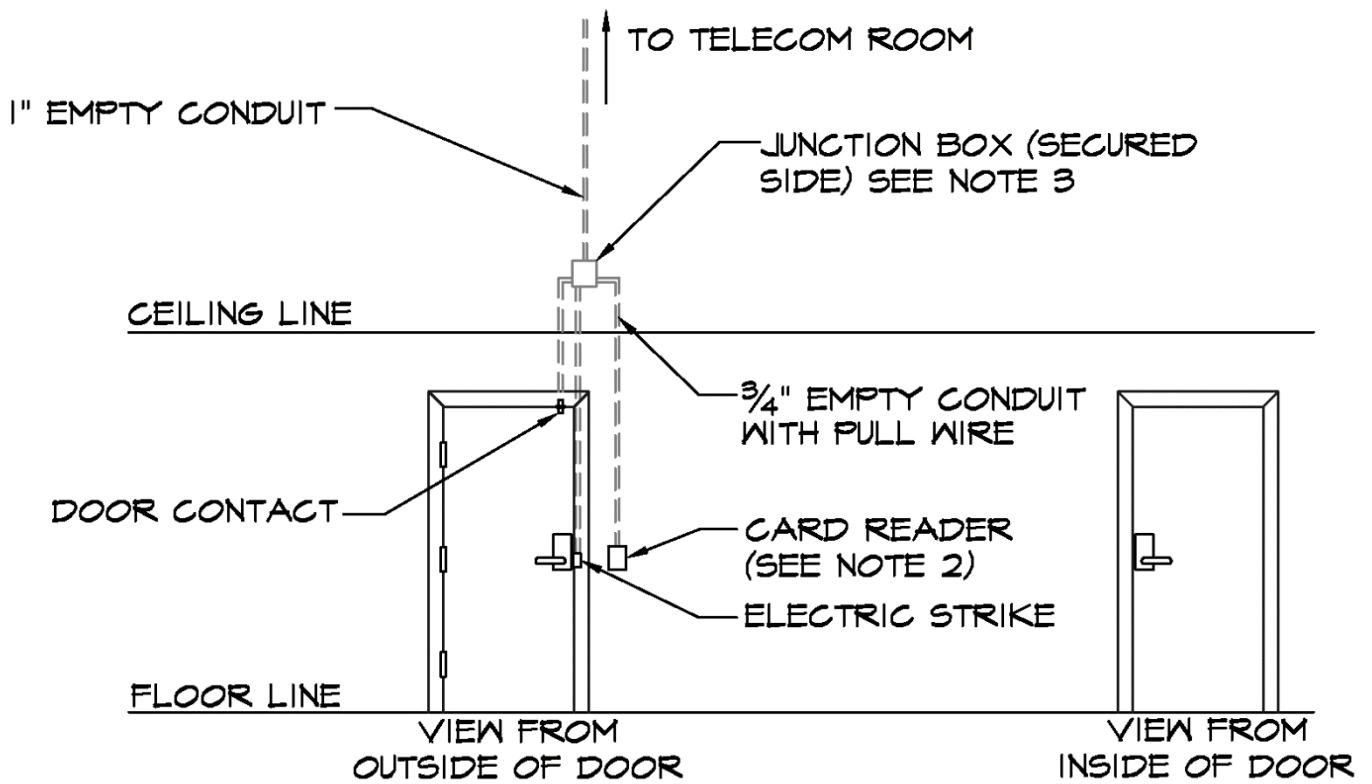

CARD READER FOR ELECTRIC STRIKE

APPENDIX B – CARD READER DETAILS

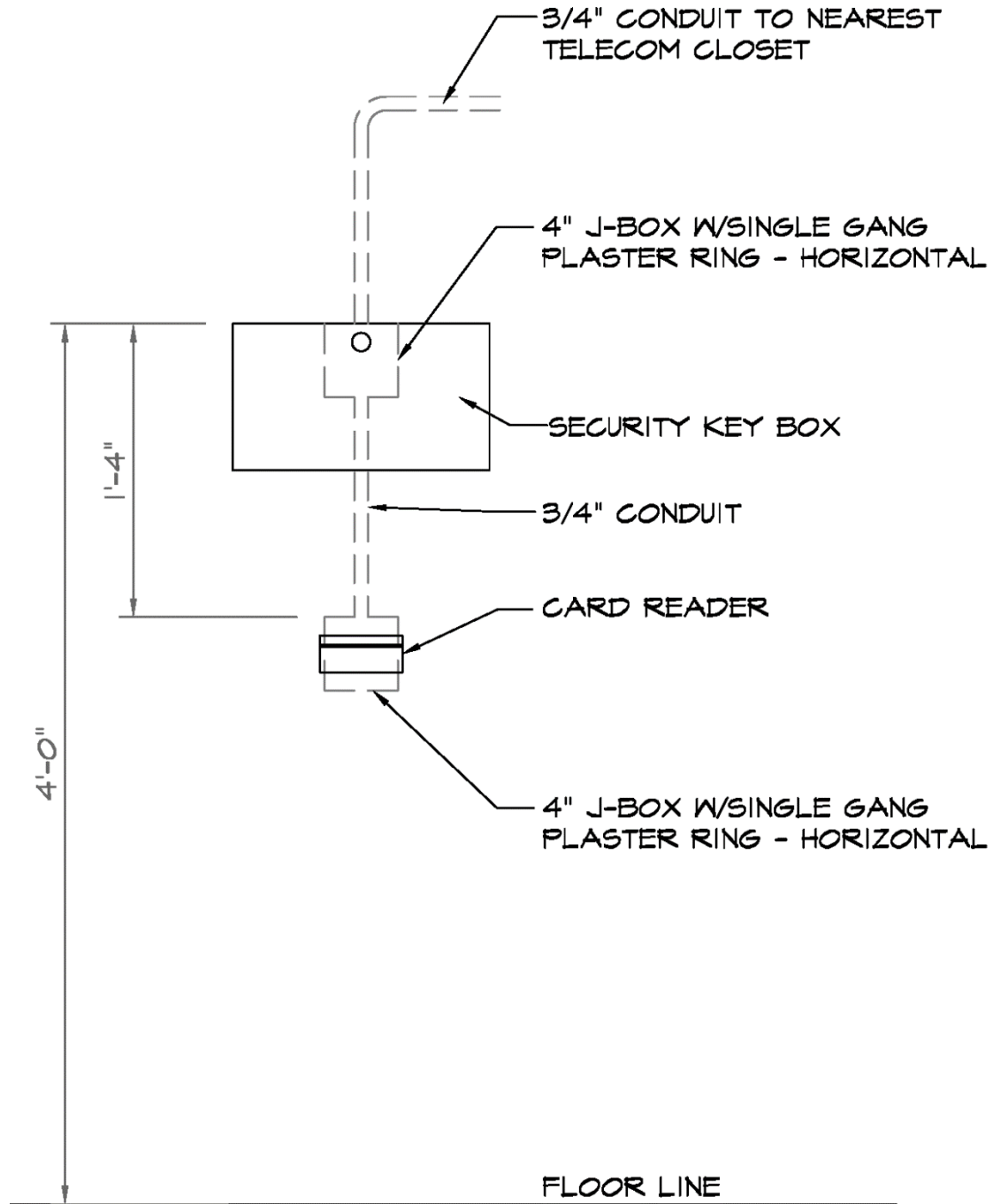

ORL KEY BOX ROUGH-IN  
DIAGRAM (TYPICAL)

GENERAL ELECTRICAL NOTES:

1. ALL 120 VOLT POWER MUST BE AN EMERGENCY CIRCUIT.
2. DOOR HARDWARE MUST BE 24 VOLT DC FAIL SECURE.
3. HANDICAP OPERATOR POWER MUST BE ON AN EMERGENCY CIRCUIT.
4. ALL DOOR FRAMES PREPPED FOR CARD READER AND DOOR POSITION SENSOR.

GENERAL NOTES

NOTE 1 - SINGLE GANG TILE BOX IN JAMB, STRIKE SIDE.

NOTE 2 - SINGLE GANG BOX MOUNTED VERTICALLY.

NOTE 3 - DEEP DOUBLE GANG BOX.

NOTE 4 - ALL ELECTRIC PANIC DEVICES NEED POWER SUPPLY PROVIDED FOR DEVICE.

NOTE 5 - ALL TO HAVE A CLOSURE.

NOTE 6 - GREENFIELD OR 1/2" CONDUIT IS NOT PERMITTED TO BE USED.

## APPENDIX C – CURED-IN-PLACE PIPE TECHNICAL SPECIFICATIONS

### 1. SCOPE OF WORK

- A. This specification consists of the method and process for furnishing all labor, materials, tools, equipment and incidents necessary to provide complete rehabilitation of gravity sanitary sewers by installation of a thermo setting, polyester or epoxy vinyl ester resin, vacuum impregnated flexible polyester fill tube having an impermeable inner surface.
- B. Sewers to be rehabilitated, tested and sealed under this process are shown on the plans.
- C. All necessary bypass pumping, including appurtenances necessary to maintain sewer service is also part of the work specified under this Section.
- D. Qualification

#### 1. Contractor

All work shall be performed by a qualified contractor using cured-in-place piping from a qualified manufacturer. The qualified contractor shall be a licensed contractor of the qualified manufacturer. In order to qualify for the project, contractors shall have successfully installed a minimum of 50,000 lineal feet of similar sized cured-in-place pipe. Any contractors wishing to qualify shall submit a qualification submittal to the Engineer. Submittals must be received with the bid package.

The qualification submittal shall include the Contractor's name with a contact person, license number, address, phone number, fax number, description of previous projects totaling a minimum of 50,000 lineal feet of similar sized pipe, and at least three (3) references who are familiar with the cured-in-place process and the quality of the Contractor's work. A contact person and phone number shall be provided for each reference.

Prime Contractors that have been pre-qualified on previous cured-in-place lining projects shall not be required to resubmit qualification documentation for this project.

#### 2. Manufacturer

Any manufacturer wishing to qualify shall have successfully had 100,000 lineal feet of similar sized cured-in-place pipe installed. The manufacturer shall have a minimum of three (3) years experience in the installation of cured-in-place pipe. Any manufacturers wishing to qualify shall submit a qualification submittal to the Engineer with the bid package.

## APPENDIX C – CURED-IN-PLACE PIPE TECHNICAL SPECIFICATIONS

The qualification submittal shall include the Manufacturer's name, address, phone number, fax number, description of previous projects totaling a minimum of 100,000 lineal feet of similar sized pipe, number of years with experience in the installation of cured-in-place pipe, and at least three (3) references who are familiar with the cured-in-place process and the quality of the Manufacturer's product. A contact person and phone number shall be provided for each reference. The manufacturer shall also submit general information about the product, including documentation that the product meets applicable ASTM standards, and any other information that would help the Engineer determine the qualification of the manufacturer.

Manufacturers that have been pre-qualified on previous cured-in-place lining projects shall not be required to resubmit qualification documentation for this project.

### 2. **SYSTEM DESCRIPTION**

- A. The CIPP when cured shall have the following values when tested in accordance with ASTM F 1216:

<u>Physical Characteristic</u>	<u>Minimum Values</u>	<u>Test Method</u>
Flexural Strength.....	4,500 psi.....	ASTM D790 mod.
Modulus of Elasticity.....	250,000 psi.....	ASTM D790 mod.
Tensile Strength.....	3,000 psi.....	ASTM D638
Chemical Resistance .....	Loss not to.....	ASTM D453
	exceed the	
	above values	

- B. The existing host pipe shall be considered **fully deteriorated** for design calculations.
- C. Contractor shall confirm loadings on buried pipe based on depths, soil conditions and water table. The height of water table shall be the same as the depth of soil above the pipe. The design soil unit weight shall be 120 pounds per cubic foot. The pipe shall also be designed for an additional AASHTO HS-20 highway live load condition.
- D. All pipes shall be designed with a minimum of 2% ovality in the circumference. Any deviation must be approved by the Engineer.
- E. Thickness of CIPP shall be rounded to the next higher multiple of 1.5 mm, after adding an allowance of 5% to the design thickness for resin migration per manufacturer recommendation.

## APPENDIX C – CURED-IN-PLACE PIPE TECHNICAL SPECIFICATIONS

The minimum CIPP design thickness shall meet the requirements of equations XI.1, XI.2, XI.3, and XI.4 in the appendixes of ASTM F 1216.

G. The following values shall be used in submitted design calculations:

Initial Flexural Modulus	=	250,000 psi
Long-Term CIPP Creep	=	50%
Overall Safety Factor	=	2.0
Soil Height	=	maximum project soil height
Modulus of Soil Reaction	=	700 psi
Ground Water Height	=	maximum project soil height
Bending Stress Safety Factor	=	2.0
Initial Flexural strength	=	4500 psi
Resin Seal Factor	=	5%
Pipe ovality or Deflection (as a %)	=	2.0%
Long-Term Flexural Modulus	=	125,000 psi
Long-Term Flexural Strength	=	2,250 psi
Water Buoyancy Factor	=	0.67 minimum

Values not listed in this specification shall be approved by the Engineer prior to submittal of design calculations.

H. **The minimum acceptable installed liner thickness for a 6” diameter shall be 4.5 mm. The minimum acceptable installed liner thickness for an 8” diameter shall be 6.0 mm. The final liner thickness shall not include non-structural thickness of calibration tubes.**

### 3. QUALITY ASSURANCE

- A. The materials and the method of installation shall be in accordance with ASTM standards and in accordance with manufacturers recommendations.
- B. The Contractor shall test all sewers, service line connections and piping reconstructed under this Contract.
- C. All testing shall be done by the Contractor or an independent testing firm approved by the Engineer.

### 4. REFERENCES

- A. Codes, specifications, and standards, referred to by number or title, shall form a part of this specification to the extent required by the reference thereto. Latest revision shall apply in all cases.

## APPENDIX C – CURED-IN-PLACE PIPE TECHNICAL SPECIFICATIONS

1. Following is a partial list of American Society of Testing & Materials which are applicable to this specification.
  - a. ASTM-F1216-93 Standard Practice for Rehabilitation of Existing Pipelines and Conduits by the inversion and Curing of a Resin-Impregnated Tube
  - b. ASTM-F1743-96 Standard Practice for Rehabilitation of Existing Pipelines and Conduits by Pulled-in-Place Installation of Cured-In-Place Thermo Setting Resin Pipe (CIPP)
  - c. ASTM-D-5813-95 Standard Specification for Cured-In-Place Thermosetting Resin Sewer Pipe
  - d. ASTM-D-790-00 Standard Test Methods for Flexural Properties of Unreinforced and Reinforced Plastics and Electrical Insulating Materials
  - e. ASTM-D-638-01 Standard Test Method for Tensile Properties of Plastics

### 5. **SUBMITTALS**

#### A. SHOP DRAWINGS

The Contractor shall submit at least five (5) copies of shop drawings to the Engineer for approval. The shop drawings shall include the items listed below:

1. Contractor's Stamp verifying Contractor's approval on each shop drawing. Shop drawings shall not be approved without a Contractor's stamp.
2. The design installed wall thickness of CIPP to be rehabilitated as recommended by manufacturer. Design calculations used to determine wall thickness shall be provided. The liner thickness shall be approved by the Engineer prior to liner manufacture or installation.
3. Data on resin and recommended curing cycle to Engineer for approval.
4. Proposed installation method.

#### B. PRE-CONSTRUCTION VIDEO

1. Provide two (2) copies of tapes of the video inspection performed no longer than 24 hours prior to installation of the CIPP. Videotapes shall include voice description, as appropriate, with stationing of services indicated. Data and stationing to be on videotapes. Videotapes shall begin at Station 0.0 Ft.

## APPENDIX C – CURED-IN-PLACE PIPE TECHNICAL SPECIFICATIONS

### C. POST CONSTRUCTION SUBMITTALS

1. Provide two (2) copies of videotapes of sewer after installation of CIPP. Video tapes shall include voice description as appropriate with stationing of services indicated. Data and stationing to be on videotapes. Videotapes shall begin at Station 0.0 ft.
2. Provide one (1) copy of multiple CD's containing one MPV file for each post TV inspection of the liner from manhole to manhole. The CD's may be filled to capacity with as many MPV files that will fit on a CD. Each MPV file will be labeled with corresponding manhole numbers of the line segment inspected. For example, a file containing TV information of a liner inspected from manhole 28000 to manhole 28001 would be labeled "28000- 28001.MPV".
3. Certified copies of all test reports on the properties of the selected resin and later, on the field liner samples, performed by an approved independent testing company, shall be submitted to the Engineer.

### 6. **PRODUCT HANDLING**

1. The Contractor shall use all means necessary to protect sewer line materials before, during, and after installation and to protect the installed work and materials of other trades. In the event of damage, the Contractor shall immediately make all repairs and replacements necessary to the approval of the Engineer, at no additional cost to the Owner.

### 7. **SITE CONDITIONS**

- A. The Contractor shall satisfy himself of the condition of the sewer sections or pipeline to be lined. The Contractor shall be responsible for verifying the size and condition of the existing sewer and his ability to insert the CIPP liner, prior to ordering materials, by TV inspection and shall not receive compensation for excavations to remove obstructions due to conditions of which he could have informed himself.
- B. Prior to entering access areas such as manholes or inspection hatches and performing inspection or cleaning operation, an evaluation of the atmosphere to determine the presence of toxic, flammable vapors or lack of oxygen must be undertaken by the Contractor in accordance with local, state and federal OSHA safety regulations.
- C. TELEVISION INSPECTION

1. No longer than 24 hours prior to installation, all sewer sections and

## APPENDIX C – CURED-IN-PLACE PIPE TECHNICAL SPECIFICATIONS

pressure pipelines which are to receive the CIPP are to be inspected by closed circuit television to confirm any changes that may have occurred from the date of the original inspection. All sewers or pipelines are to be cleaned as stated below prior to the television inspection.

2. The television inspection shall be performed in order to supply a visual and audio record of the location of obstructions in the sewer that would interfere with or prohibit lining of the sewer and provide the location of service laterals that are to be reconnected to the new CIPP. A color television inspection camera with pan and tilt capability is required for all inspections.
3. Videotapes, CD's, and hard copy reports shall be made for each line inspected. The quality of the tapes shall be such that obstructions and service lateral locations are clearly identified and can be located. The Contractor shall make the tapes, CD's, and reports available to the Owner for review. Areas in the pipe where camera is underwater shall be cleared of debris prior to or during inspection to allow complete survey of pipe. Post construction video with "camera underwater" conditions due to debris will not be accepted.
4. If there is an obstruction in the sewer line that will not allow the television camera to pass, then the camera shall be backed out of the line and an attempt shall be made to televise the line from the manhole at the other end. If the entire length of the sewer line cannot be televised because of two or more obstructions, then the Engineer shall be notified and a determination of how to proceed shall be made by the Engineer.
5. The Contractor shall provide a videotape and CD of the finished CIPP after accepted by the Owner.
6. The cost of the television inspection, videotapes, CD's, and reports shall be included in the unit cost of the CIPP.

### 8. **WARRANTY**

The manufacturer shall warrant all materials to be free from defects in workmanship and materials for a period of one (1) year after final acceptance.

### 9. **MATERIALS**

#### A. TUBE

1. The tube should consist of two or more layers of flexible needled felt or

## APPENDIX C – CURED-IN-PLACE PIPE TECHNICAL SPECIFICATIONS

an equivalent nonwoven material capable of: carrying resin, withstanding installation pressure, installation tension (if pulled in place) and curing

temperatures, and should be compatible with the resin system recommended by the manufacturer.

2. The material shall be able to stretch to fit irregular pipe sections and negotiate bends.
3. The tube shall be fabricated to a size that, when installed, will tightly fit the internal circumference and the length of the original sewer or pipe.
4. Allowance shall be made for circumferential stretching during installation.
5. The fabric tube and seam (if applicable) shall be tested in accordance with Test Method D1682. The tube shall have a minimum tensile strength of 750 psi in both the longitudinal and transverse directions.

### B. RESIN

1. The resin system shall be a corrosion resistant polyester, vinyl ester, or epoxy and catalyst system that meets the requirements of ASTM F1216 and the physical properties herein.

## 10. SURFACE PREPARATION

- A. All sewer sections that are to receive the CIPP are to be thoroughly cleaned and all debris, roots and other obstructions removed. All material removed from the existing sewer sections shall be properly transported to an approved disposal site obtained by the Contractor on a daily basis. Under no circumstances will the Contractor be allowed to accumulate debris or to create a public nuisance.
- B. The method used to clean the sewer sections shall be at the option of the Contractor and may include high pressure water jet cleaning, brushes, balls, swabs, bucket machine or other methods. The Contractor shall be responsible for damage to the sewer sections due to improper cleaning methods.
- C. The cost of preparatory cleaning shall be included in the unit price of the CIPP.
- D. REMOVAL OF OBSTRUCTIONS IN SEWER
  1. Obstructions in the sewer sections which cannot be dislodged or cleared by cleaning, bucketing, dragging a mandrel, or other internal methods shall be cleared by excavation. The Contractor shall notify the Engineer

## APPENDIX C – CURED-IN-PLACE PIPE TECHNICAL SPECIFICATIONS

prior to any excavation work that is performed that is not indicated on the plans.

2. The excavation shall conform to requirements of Section VI-1, “Excavation,” and shall be located to minimize the obstruction of traffic where possible. The size of the excavation shall be kept to a minimum and shall be shored and sheeted as required.
3. The existing sewers shall be repaired, after the obstruction is removed, in accordance with MSD Standards.
4. If more than two obstructions require excavation in any one sewer section, the Contractor shall notify the Engineer and a determination of how to proceed shall be made by the Engineer.

### 11. **FIELD MEASUREMENTS**

The Contractor shall make all necessary measurements in the field to ensure precise fit of items in accordance with the drawings. In the event of a discrepancy, the Contractor shall immediately notify the Engineer. The Contractor shall not proceed with installation in areas of discrepancy until all such discrepancies have been fully resolved.

### 12. **INSPECTION OF PIPE LINER**

Each pipe liner shall be subject to inspection by the Engineer immediately before it is installed. Defective liner or undersized tube thickness liner will be rejected for use on the project.

### 13. **INSTALLATION**

#### A. INSERTION OF CURED-IN-PLACE PIPE

1. The Contractor shall make every effort to maintain service usage throughout the duration of the project. In the event that a service will be temporarily out of service, the maximum amount of time of no service shall be 8 hours for any property served by the sewer. The Contractor shall be required to notify the Owner and all affected properties whose service laterals will be out of commission and to advise against water usage until the sewer main is back in service. Such notifications shall be provided to Owner at least one week prior to service disconnecting.
2. The Contractor shall provide for continuous sewage flow around the sections(s) of pipe designated for insertion of liners, when required for acceptable completion of an insertion process. The pump and bypass line shall be of adequate capacity and size to handle the flow.
3. The Contractor shall designate a location where the felt tube will be impregnated (“wetted out”) with resin using distribution rollers and vacuum, to thoroughly saturate the felt tube prior to its dispatch for

## APPENDIX C – CURED-IN-PLACE PIPE TECHNICAL SPECIFICATIONS

installation. The Contractor shall inform the Engineer in advance to inspect the materials and the wet out procedure. A catalyst system or additive(s) compatible with the

resin and tube may be used as per the manufacturer's recommendation. They shall, however, not impair or reduce the resin's quality to withstand the minimum chemical resistance criteria.

4. The wetted out tube shall be transported and kept in a refrigerated truck until it is inserted through an existing manhole by approved techniques/process of the installer or the Contractor. The insertion area, equipment platform, etc., shall be securely protected, and all damaged yards, driveways, walks, etc., shall be repaired at no cost to the Owner.
5. The liner may be installed by inversion method per ASTM F1216 or by the pulled-in-place method per ASTM F1743.
6. Water inversion shall be accomplished by using natural water pressure (head) only. Natural water pressure shall be achieved by erecting platforms or scaffolding to an elevation determined by the Contractor necessary to provide adequate inversion heads (pressures). CIPP installation vessels/units used to create water pressure shall not be used. Water pressure shall not be varied by any means throughout the inversion process except by increasing the height of the platform/scaffolding. The Contractor shall submit required inversion heads for each installation, as a shop drawing without delay and claim to confidentiality of product/installation privacy.
7. After the insertion is completed, the Contractor shall use a hot water re-circulation system, capable of delivering desired heat uniformly throughout the section, for a consistent cure of the resin. All water used shall be from metered supply and paid for to the Water System Owner through the regular billing system. The curing temperatures shall be recommended by the resin/catalyst system of the resin manufacturer. The heat source shall be fitted with suitable monitors to gauge the temperature of the incoming and outgoing heat source. Another such gauge shall be placed between the impregnated tube and the invert to the original pipe at the manhole(s) to determine the temperatures during the resin curing process. Initial cure may be considered completed when the exposed portions of the felt tube pipe appear to be hard, and the remote sensing device indicates the temperatures to be adequate, as recommended by the resin/catalyst system manufacturer, and approved by the Engineer. Curing temperatures and duration shall comply with previously submitted data and information.
8. The Contractor shall cool the hardened pipe to a temperature below 100°F before relieving the water column. Cool water may be added to the water column while draining hot water from a small hole at the opposite end of the CIPP, so that a constant water column height is maintained until cool-down is completed. Care shall be taken in the release of the water column

## APPENDIX C – CURED-IN-PLACE PIPE TECHNICAL SPECIFICATIONS

so that a vacuum will not be developed that could damage the newly installed pipe. Liner samples shall be obtained for testing at this time.

Cool down process may vary depending on the installation technique of the manufacturer/contractor.

9. The finished CIPP shall be continuous over the entire length from manhole to manhole and be free from visual defects such as foreign inclusions, dry spots, keel, boat hull, pinholes, wrinkles and other deformities. The liner passing through or terminating in a manhole shall be carefully cut out (also for samples) in a shape and manner approved by the Engineer. The invert and benches shall be streamlined and improved for smooth flow. The area/annular space between existing and the CIPP shall be sealed with approved materials in an approved manner described within the specifications. It shall also meet the leakage requirements of pressure test as specified. During the warranty period, which shall be defined as twelve

(12) calendar months after final acceptance by the Owner, any defect which will affect the integrity or strength of the pipe or impede the flow through the pipe shall be repaired at the Contractor's expense, in a manner mutually agreed to by the Owner, Engineer and the Contractor.

### B. SEALING AND BENCHES IN MANHOLE

1. The CIPP shall make a tight fitting seal with the existing pipe(s) in the manhole. 1/2" diameter activated oakum band soaked in Scotch Seal 5600 or equal, shall be applied circumferentially near the annular space touching the end of existing pipe and encased with a cementitious mortar. Top half of the pipe shall be neatly cut off and not broken or sheared off, at least 4" away from the walls and a pipe collar built over pipe. The channel in the manhole shall be smooth continuation of the pipe(s) and shall be merged with other lines or channels, if any. Channel cross-section shall be U-shaped with a minimum height of 6" for 8" pipe and full depth for greater sized pipes. The side of the channels shall be built up with mortar/concrete to provide benches at a 1 in 12 pitch toward the channel. All grout work including invert bench and pipe collars are to have a steel trowel finish.
2. Payment for above work shall be incidental to sewer rehabilitation by the CIPP method, since that payment is made from centerline to centerline of manhole(s), be that the end of the liner.
3. The CIPP and the existing pipe in the manhole must be sealed as above before proceeding on to the next manhole section, and all manholes shall be individually inspected for liner cut-offs, benches and sealing works.

### C. SERVICE / OUTSIDE DROP RECONNECTIONS

## APPENDIX C – CURED-IN-PLACE PIPE TECHNICAL SPECIFICATIONS

1. After the pipe liner has been formed in place, the Contractor shall reconnect the existing active service connections as designated by the Engineer. This shall be done without excavation unless otherwise directed by the Engineer,  
from the interior of the pipeline by means of a television camera and a cutting device that re-establishes the service connections to not less than 90 percent capacity.
2. The exact location and number of service connections shall be determined from TV tapes and/or in the field. It shall be the Contractor's responsibility to accurately field locate all existing service connections whether in service or not. *The Contractor shall reconnect all active service connections to the liner pipe, unless directed otherwise by the Engineer.* The Contractor shall be responsible for restoring/correcting without any delay, all missed or faulty reconnections, as well as for any damage caused to property owners for not reconnecting the services soon enough or for not giving notice to the Owners. All services which are reconnected to rehabilitated liner shall be shown on the "Record Drawings" with the exact distance from the nearest upstream/downstream manhole.
3. All existing service connections shall be reconnected by Remote TV Controlled Cutting Device method. In the event that the remote cut does not meet the Engineer's approval with respect to quality and workmanship, the service connection shall be performed by excavation at no additional cost to the Owner.
4. The Engineer may direct the Contractor to replace the service lateral from the main line to the clean-out assembly (See No. 6 of this section).
5. Service Connection by Remote Cut
  - a. All service connections shall be done by TV controlled Remote Cutting Device unless otherwise directed by the engineer. These shall be made by experienced operators so that no blind attempt or holes are made in the liner pipe. Location shall be re-verified carefully with earlier tapes for accuracy, especially where dimples are not defined or clearly ascertained. The Engineer reserves the right to require service connection by excavation at certain or all locations at no additional cost to the Owner, if the quality, workmanship and approval rating for remote cut is poor and not satisfactory.
  - b. The remote cut shall be smooth and circular in nature as seen by a 360° TV camera. The hole shall be a maximum of 100% and a minimum of 90% of the service pipe diameter. It shall be properly aligned and be concentric to the existing connection. The

## APPENDIX C – CURED-IN-PLACE PIPE TECHNICAL SPECIFICATIONS

locations of all remote cuts shall be verified carefully to match with earlier tapes for their exact locations. Excess, wrong holes or trial cuts shall not be made and must be repaired at no cost to the Owner to the full satisfaction of the Engineer. The Engineer may check the completed

remote connections for the minimum 90% requirement by excavating the site, in which case payment shall be made for the excavation at the location and for any special backfill, if necessary. Defective connections shall be repaired to the Engineer's satisfaction at no extra cost.

- c. Protruding taps that will obstruct or hinder the insertion of the liner, shall be removed to allow the liner to pass through. If these taps are to be reinstated at a later time by excavation, the initial removal will be incidental. If the camera equipment cannot pass, the trimming will be paid as a removal of protruding service by remote cut upon approval by Engineer.
- d. Outside drop pipes at drop manholes shall be reconnected by remote cut. Payment for this reconnection shall be the same as for a service connection by remote cut.

### 6. Service Connection by Excavation

- a. In the event of poor quality or workmanship of the remote cut, or if service lateral replacement is directed by the Engineer, the existing service connections may be done by Excavation method with the Engineer's approval. The existing sewer (now the carrier or host pipe for the liner) shall be carefully broken/removed to expose the liner to the extent necessary. The liner pipe shall not be damaged and shall be allowed to normalize to ambient temperature and cool down, before a 4" or 6" diameter hole is cored out with a hole saw. This coupon shall be retrieved and handed over to the Engineer for inspection of the liner thickness at that location, if so required. The size of new service shall match the existing service size.
- b. A three piece service connection shall be installed consisting of an IPS/Schedule 40 PVC hub, rubber sleeve and 301 stainless steel band. The service connection shall be a compression fitting such as INSERTA TEE as manufactured by Inserta Fittings Company or equal for 8" and larger mains. The rubber sleeve shall meet ASTM C443. The PVC hub gasket shall meet ASTM F477.

## APPENDIX C – CURED-IN-PLACE PIPE TECHNICAL SPECIFICATIONS

- c. The rubber sleeve shall be lubricated as recommended by the manufacturer. The rubber sleeve shall be inserted into the pipe liner such that the entry lip forms a complete seal between the inside of the pipe liner and the sleeve entry lip. The PVC hub shall be inserted into the rubber sleeve to the mark shown on the outside of the hub. The hub shall not protrude into the pipe liner such that a TV camera cannot pass.
- d. Place the stainless band around the top of the rubber sleeve and tighten down. Install lateral service pipe in the normal manner.
- e. If directed by the Engineer, the contractor shall replace the existing service line to the clean-out assembly.
- f. One or more homes discharging into a common connection shall be considered as one service connection. Damage repair to residences or properties due to delay or faulty connections shall be incidental.
- g. Compression fittings shall not be used on 6" main lines. Saddles shall be used for 6" lines as shown on the plans.

### D. TESTING

A sample shall be cut from a section of cured CIPP at the installed liner termination point, that has been inverted through a like diameter pipe which has been held in place by a suitable heat sink, such as sandbags. Each sample shall be large enough to provide a minimum of three specimens and a recommended five specimens for flexural testing.

Thickness measurements, flexural stress, flexural modulus of elasticity, and tensile tests shall be performed for each sample. Eight thickness measurements shall be made per ASTM D2122 and the average thickness shall be the determined sample thickness. The minimum wall thickness at any point shall not be less than 87.5% of the specified thickness.

Five specimens of each sample shall be tested for flexural stress and flexural modulus of elasticity per ASTM D790. The dimensions of each specimen including width, depth, and span shall be reported. Data items shall be reported for each of five specimens tested as follows:

Specimen Number  
Displacement at Yield  
(in) Strain at Yield (in /  
in) Load at Yield (lbs.)  
Stress at Yield (psi)  
Modulus of Elasticity  
(psi)

The mean, standard deviation, minimum value, and maximum value for

## APPENDIX C – CURED-IN-PLACE PIPE TECHNICAL SPECIFICATIONS

the group of specimens shall be reported for each data item.

Each report shall contain sample identification information for each sample including project name, sample number, date sample received, date sample tested, diameter of liner sample, upstream manhole number and downstream manhole number where sample taken.

Sample conditioning information such as humidity and temperature shall be provided on each report. Sample reports submitted to the Engineer without the specified data shall be rejected. The sample report, *which is included at the end of this section*, shall be used as a guide for this project.

Tensile tests shall be performed per ASTM-D-638-01.

### 14. **SERVICE LATERAL REHABILITATION**

- A. For all service connections that do not currently have a clean-out assembly installed at the edge of the road right-of-way or prescriptive right-of-way, the Contractor shall install a clean-out assembly on the existing service lateral. Laterals to have clean-outs installed shall be approved by the Engineer's field representative prior to installation.

Clean-out assemblies shall be installed in accordance with Owner's standard details and technical specifications.

- B. In addition to the television inspection that will be required prior to installation of the cured-in-place pipe, all service laterals shall be inspected. The method of televising service laterals may be chosen by the Contractor, but must be coordinated and approved by the Engineer prior to inspection of the laterals.

The Contractor shall coordinate each service lateral inspection with the Engineer's field representative. At the time of the inspection, the field representative shall make a decision whether to replace the lateral or not. The field representative may determine that replacement of the lateral is not required.

- C. If it is determined that the lateral needs to be replaced, the Contractor shall replace the existing service line from the clean-out to the main collection system line by means of open-cut excavation. Service laterals shall be constructed in accordance with Owner's standard details, the Special Conditions (Section V), and Section VI  
– II of the Technical Specifications.

### 15. **FIELD QUALITY CONTROL**

- A. The manufacturer of the CIPP material shall provide technical and installation

## APPENDIX C – CURED-IN-PLACE PIPE TECHNICAL SPECIFICATIONS

advice to the Contractor work force when first installing the CIPP. The service of an experienced installation representative shall be provided for a minimum of two days at no additional cost to the Owner.

- B. Video tapes shall be required after the liner has been installed in the existing sewer pipe, at no additional cost to the Owner. The televising shall be done after all service connections have been made, unless required earlier by the Engineer.
- C. A smoke test shall be performed on all service line connections made by open excavation that are constructed due to poor quality or workmanship of the remote cut, at no extra cost to the Owner. No excavated taps shall be backfilled until completion of this test. The Contractor shall isolate the manhole section to be tested from the adjacent manhole sections to prevent smoke from migrating into lines not being tested, as well as to provide a concentration of smoke in the section being tested.
- D. All smoke testing shall be closely coordinated with and scheduled through the Owner. Before smoke testing, written notice(s) shall be given to the area residents not fewer than two (2) days, nor more than seven (7) days, prior to the proposed testing. Notice shall also be given to the local Police Department and local Fire Station, twenty-four (24) hours prior to actual smoke testing. This test shall be conducted by forcing smoke from smoke generators, through the newly rehabilitated sanitary sewer main. The smoke generators shall have a minimum duration of five (5) minutes with a capacity of 1500-2000 cfm.
- E. Smoke shall be introduced as per the Manufacturer's recommendations. The Engineer, accompanied by the Contractor, shall check each service line connection being tested. Sources of all leaks must be found and noted for correction.
- F. All service line connections noted as leaking shall be repaired or replaced and then retested. The Contractor may be allowed to leave the service line connection exposed in one (1) manhole section at a time, to minimize inconvenience and hazard to the residents. If service line connection repair or replacement, testing or retesting, and backfilling of the excavation is not completed within the work day, the Contractor shall properly cover each excavation with steel plates, plywood, or some other approved material, to keep the area secure from accidents or hazard.
- G. In houses where smoke does not issue from the plumbing vent stacks to confirm the reconnection of the sewer service to the newly installed liner, a dye test may be required to confirm the reconnection. Dye shall be introduced into all service lines and then each line shall be flooded with water. The Contractor and the Engineer shall look to the downstream manhole to detect the dye coming out of the sewer main. This shall confirm a reconnection. If any more than one service connection is dye tested at a time, these dye tests shall be done with enough time allowed between each test to allow the dye to be purged from the line. Otherwise, different colored dyes shall be used. Dye testing shall be performed by the

## APPENDIX C – CURED-IN-PLACE PIPE TECHNICAL SPECIFICATIONS

Contractor at no additional cost to the Owner.

### 16. **POST TELEVISIONING OF COMPLETED SECTIONS**

- A. The Contractor will provide to the Engineer a color video tape taken by a 360° radial view camera for close up view, showing the completed work, including the condition of the restored pipes prior to requesting payment.
  
- B. Television inspection, tapes and report, etc., shall be as specified elsewhere in this section. Upon completion of the installation work and testing, the Contractor shall restore/clear the project area affected by his operations. No trash, rubbish etc., shall be stored at any site, be the work in progress or not.

### 17. **CLEAN-UP**

- 1. The contractor shall restore or replace all removed or damaged paving, curbing, sidewalks, gutters, shrubbery, fences, sod or other disturbed surfaces or structures in a condition equal to that before the work began, to the satisfaction of the Engineer, and shall furnish all labor and material incidental thereto.
  
- 2. Surplus liner material, tools and temporary structures shall be removed by the Contractor. All dirt, rubbish and excess earth from operation shall be legally disposed of by the Contractor, and the construction site shall be left clean, to the satisfaction of the Engineer.

### 18. **PATENTS**

The Contractor shall Warrant and save harmless the Owner against claims for patent infringement and any loss thereof.

# FIRE ALARM PERFORMANCE GUIDELINES

**TABLE OF CONTENTS**

**PART 1 GENERAL ..... 3**  
     1.1 RELATED DOCUMENTS ..... 3  
     1.2 SCOPE..... 3  
     1.3 QUALITY ASSURANCE..... 3  
     1.4 SUBMITTALS ..... 5

**PART 2 PRODUCTS..... 6**  
     2.1 MANUFACTURER'S / MODEL'S..... 6

**PART 3 SPECIFIC SYSTEM PERFORMANCE GUIDELINES..... 6**  
     3.1 FIRE ALARM CONTROL PANEL (FACP) ..... 6  
     3.2 DIGITAL ALARM COMMUNICATOR TRANSMITTER (DACT) ..... 12  
     3.3 AUXILIARY POWER SUPPLY PANELS (APS)..... 12  
     3.4 ANNUNCIATION DEVICES ..... 14  
     3.5 EMERGENCY VOICE / ALARM COMMUNICATIONS ..... 16  
     3.6 INITIATING DEVICES..... 17  
     3.7 MONITOR AND CONTROL DEVICES..... 20  
     3.8 MISCELLANEOUS SYSTEM ITEMS..... 21

**PART 4 SYSTEM TESTING & CERTIFICATION..... 23**  
     4.1 CONTRACTOR/INSTALLER TESTING & CERTIFICATION ..... 23  
     4.2 A/E TESTING & CERTIFICATION ..... 23  
     4.3 OWNER TESTING & INSPECTION..... 23  
     4.4 SYSTEM ACCEPTANCE ..... 24

**PART 5 SYSTEM DOCUMENTATION, TRAINING & MAINTENANCE ..... 25**  
     5.1 SYSTEM DOCUMENTATION..... 25  
     5.2 SYSTEM TRAINING AND MAINTENANCE..... 26

**PART 6 ALTERNATES AND ATTACHMENTS..... 27**  
     6.1 ALTERNATES ..... 27  
     6.2 ATTACHMENTS..... 29  
         A. TRANSFER OF SYSTEM RESPONSIBILITY/LIABILITY ..... 29

## PART 1 - GENERAL

### 1.1 RELATED DOCUMENTS

- A. Drawings and general provisions of Contract, including General and Supplementary Conditions and Division-1 Specification sections, apply to work of this section.

### 1.2 SCOPE

- A. This section of the specifications includes the furnishing, installation, and connection of the microprocessor controlled, addressable reporting fire alarm equipment required to form a complete coordinated system ready for operation. It shall include, but not be limited to, alarm initiating devices, alarm notification appliances, control panels, auxiliary control devices, annunciators, power supplies, smoke evacuation systems, and wiring as shown on the drawings and specified herein. It also includes the connections and appurtenances necessary to interconnect with the existing system as described above.
- B. The University maintains and services all fire alarm equipment on campus. The Contractor shall provide any site specific and end user type training of the system. Additionally, where any specific computers, printers, cabling, software and/or license agreements are necessary for the University to have the capability to develop a database and/or modify any operating scenario for the buildings fire alarm system without permission from outside distributors, a schedule of available manufacture certification training shall be provided. This training and certification shall recognize the University as a trained and licensed Fire Alarm System installer independent of local distributors and shall not be included in the price of the base bid. The authorized representative will coordinate training arrangements, costs, and specific support equipment needs with the owner.

### 1.3 QUALITY ASSURANCE

- A. **Manufacturer's Qualifications:** Firms regularly engaged in manufacture of fire alarm systems of types, sizes, and electrical characteristics required, and whose products are Listed and Labeled by UL, Inc. All products, including initiating devices and notification appliances, shall be as produced or supplied by the same manufacture as the main fire alarm control panel. Products of firms that do not maintain factory authorized service organization and spare parts stock are not acceptable for use on this project.  
Manufacturer's shall agree to make factory training/certification, product programs and/or operating systems, and continued product updates and/or Tech notes available to the University. Any licensing and/or proprietary agreements between the manufacture/distributor and the University must be completed and in place prior to the manufacture and/or product being acceptable for installation.

- B. Installer’s Qualifications:** An experienced company who is an authorized representative of the FACP manufacturer for both installation and maintenance of all equipment is required for installation of the FACP and connection of all circuits for any project. The Installer in charge shall have a minimum of 5 years documented experience installing fire detection and alarm systems similar in size and scope to this project. The Installers technicians shall be individually certified NICET Level 1 and by the manufacturer of the equipment and trained and certified on the specific model being installed. The Installer shall have at least one technician on staff certified NICET Level 3. Certifications shall be current to latest release and must have occurred in the most recent 24 months. All connections to the FACP, system programming, and/or programming changes shall be accomplished only by the Installer technicians compliant with qualifications, and must be present for the 100% pre-test, Engineer’s inspection, and Owner inspections to include SMFO inspections.
- C. Codes and Standards:** The codes and standards listed below are utilized as design criteria for “**minimal**” system coverage. The University may require additions to these codes and standards based on historical consensus criteria for design and installation of fire alarm systems specific to facility applications within University type settings.
1. **NFPA Compliance:** Comply with current applicable requirements of NFPA-72, National Fire Alarm Code.
  2. **NEC Compliance:** Comply with current applicable requirements of NFPA-70, National Electrical Code (NEC) standards pertaining to fire alarm systems.
  3. **State Building Code Compliance:** Comply with applicable requirements of the Virginia State Building Code.
  4. **Testing Laboratory Compliance:** Comply with provisions of UL safety standards pertaining to fire alarm systems. Provide products and components, which are Listed and Labeled.
  5. **FM Compliance:** Provide fire alarm systems and accessories, which are FM approved.
  6. **Comply with Authority(ies) Having Jurisdiction (AHJ):**
    - a) **VA State code requirement issues:** Virginia State Fire Marshall's office
    - b) **City of Harrisonburg code requirement issues:** Harrisonburg City Fire Marshall
    - c) **University code requirement issues:** JMU Risk Management
    - d) **University policy and system application requirements:** JMU Life Safety Shop

**D. Assumption of Existing System Responsibility/Liability:** Any construction project additions and/or renovations that will require changing the current programming of an existing fire alarm system in any way shall require an official transfer of the entire FACP system responsibility to that contractor. This also includes significantly impairing any active system to accommodate phased construction projects where the FACP will either be: removed in its entirety at the completion of the project and/or significantly modified and/or totally replaced through a dual system coverage conversion type project. A signed letter transferring the responsibility of the system as well as an emergency contact list shall be provided to the owner prior to the start of any construction. (See **Attachment A**).

**A.** Submittals shall demonstrate compliance with technical requirements by reference to each subsection of this specification. Where a submitted item does not comply fully with each and every requirement of the specifications, the submittal shall clearly indicate such deviations and may be subject to rejection. Identification requirements for non-complying features of items are very specific.

1. **Installer Certifications:** Copies of manufacturer signed certifications and NICET certifications as required in section 1.3.B above.

2. **Product Data:** Submit Manufacturer's technical product data, including specifications and installation instructions, for all system components (i.e, boards, devices and/or modules, duct mounted smoke detectors, flow switches, tamper switches, supervisory switches, and/or other similar items which require mechanical installation.) that will support the entire fire alarm system. Submit technical product data on any required fire alarm system servicing and/or support equipment.

3. **Maintenance Data:** Submit maintenance data and parts lists for each type of fire alarm equipment installed, including furnished specialties and accessories. Include this data, product data, and shop drawings in maintenance manual.

4. **Standby Battery Sizing Calculations:** Battery calculations shall be sized considering the University has its own Central Station and provides runner service. The University is considered Proprietary and a contiguous campus. For those facilities off campus, they shall be sized as a remote station.

5. **Owner Training and Certification:** Provide the owner a current factory approved certification/ training schedule for the specific system installed.

6. **Maintenance Contract:** Provide maintenance contract per [Alternate E1](#) if agreed to by all interested parties. Interested parties include: JMU Facilities Planning Project Manager, and the Life Safety department.

7. **Network Interface Connection:** Provide product data, as required above,

## APPENDIX D – FIRE ALARM PERFORMANCE GUIDELINES

for the specific equipment that is required, by the selected manufacture, to interface with Simplexgrinnell SURGuard Reciever and TrueSite Workstation Clients.

### PART 2 - PRODUCTS

#### 2.1 MANUFACTURER'S/MODELS

A. **Manufacturer's/Models:** Subject to compliance with requirements in section 1.3.A above, the current manufacturer's and corresponding panel models that are acceptable to be incorporated into the contract are limited to the following:

1. Simplex 4100ES & 4010ES or applicable model.

### PART 3 – SPECIFIC SYSTEM PERFORMANCE GUIDELINES

#### 3.1 FIRE ALARM CONTROL PANEL (FACP)

A. **FACP - Minimum Requirements:**

1. The system shall be electrically supervised for open or (+/-) ground fault conditions in SLC, alarm circuits, and control circuits. Removal of any detection device, alarm appliance, plug-in relay, system module, or standby battery connection shall also result in a trouble signal. Fire alarm signal shall override trouble signals, but any pre-alarm trouble signal shall reappear when the panel is reset.
2. Detect the activation of any initiating device and the location of the alarm condition. Operate all notification appliances and auxiliary devices as programmed.
3. Visually and audibly annunciate any trouble, supervisory or alarm condition on operator's terminals, panel display, and annunciators.
4. The FACP shall include a full featured operator interface control and annunciation panel that shall include a backlit, multi character liquid crystal display, individual, color coded system status LED's, and an alphanumeric keypad for the field operations and control of the fire alarm system.

B. **System Capacity and General Operation:** The system shall have the following capacities and general operation modes:

1. **Signal Line Circuits (SLC's):** Capacity for expansion up to at least 127 total addressable devices per SLC and up to at least 2048 total annunciation points per system. The number of SLC's provided shall be as indicated on the Drawings, with a minimum of (1) one spare for future use.

2. **Digitized Electronic Signals:** Shall employ check digits or multiple polling. In general a single ground or open on any system signaling line circuit, initiating device circuit, or notification appliance circuit shall not cause system malfunction, loss of operating power or the ability to report an alarm.

3. **System Response to an Alarm Condition:** When a fire alarm condition is detected and reported by one of the system initiating devices or appliances, the following functions shall immediately occur:

- a) The system alarm LED shall flash.
- b) A local piezo-electric signal in the control panel shall sound.
- c) The LCD display shall indicate all information associated with the fire alarm condition including: the type of alarm point, the initiating device address and the description of its physical location within the protected premises.
- d) History logging of all information associated with the event, including time and date of occurrence.
- e) Activate all system outputs, including program assigned via control-by-event equations, shall be executed by the particular point in alarm. Exact programming shall be provided by the Contractor to meet the Owners requirements prior to acceptance.
- f) Activate all fire alarm Notification Appliances in the building, sounding and flashing in synchronization continuously until manually silenced, or until the initiating device and control unit has been reset to normal condition.
- g) Activate digital alarm communication to the central station
- h) Deactivate door hold control relay such that all smoke doors are allowed to close.
- i) Deactivate control relays allowing HVAC units to stop.
- k) Activate elevator recall sequence if smoke is detected in any elevator lobby or in the elevator equipment room.
- l) Release all doors, which may be secured by “fail secure” methods.
- m) Transmission of all data to any remote annunciation panels.

4. **System Response to Trouble Conditions:**

- a) The system trouble LED(s) shall flash.
- b) A local piezo-electric signal in the control panel shall sound, and be silenced after one tone.
- c) The LCD display shall indicate all information associated with the

## APPENDIX D – FIRE ALARM PERFORMANCE GUIDELINES

trouble condition including: the type of device point, the device address and the description of its physical location within the protected premises.

- d) History logging of all information associated with the event, including time and date of occurrence.
- e) Activate digital alarm communicator.
- f) System AC power trouble signal shall not be sent unless maintained for 1 hour (or more).
- g) Provide adjustable time delay for all trouble signals prior to transmission if applicable.
- h) Transmission of all data to any remote annunciation panels.

### 5. **System Response to Supervisory Conditions (typically associated with sprinkler system monitored type devices only):**

- a) The system supervisory LED(s) shall flash.
- b) A local piezo-electric signal in the control panel shall sound, and be silenced after initial tone.
- c) The LCD display shall indicate all information associated with the supervisory condition including: the type of device point, the device address and the description of its physical location within the protected premises.
- d) History logging of all information associated with the event, including time and date of occurrence.
- e) Activate digital alarm communicator.
- f) Transmission of all data to any remote annunciation panels.

### C. **System Features:** The FACP shall be capable of providing the following features:

1. Upload/Download to PC Computer
2. Charger Rate Control
3. Drift Compensation
4. Automatic Day/Night Sensitivity Adjust if applicable
5. Device Blink Control
6. Pre-alarm Control Panel Indication
7. NFPA 72 Smoke Detector Sensitivity Test
8. Walk Test
9. System and Device Status and History Reports
10. Periodic Detector Test

11. Alarm Verification, by device, with tally
12. Printer and CRT Display Interface if applicable
13. Non-Alarm Module Reporting
14. Block Acknowledge
15. Smoke Detector Maintenance Alert - When any smoke detector approaches 80% of its alarm threshold due to gradual contamination.
16. Control-By-Time and Event

D. **Operator's Terminal:** Provide an operator's terminal, which allows the following minimum functions. In addition, the operator's terminal shall support any other functions required for system control and/or operation:

1. Acknowledge (ACK/STEP) Switch
2. Signal Silence Switch
3. System Reset Switch
4. System Test Switch
5. Lamp Test Switch
6. Bypass Switches

E. **Remote Transmissions:** On board communicators shall be acceptable on the condition of total compatibility with the owners receiving station equipment, provides dual line capability one of which is capable of communications via LAN.

F. **Power Supply(ies):** The FACP power supply(ies) shall operate on 120 VAC, 60 Hz and shall be adequate to power all equipment and functions in full alarm continuously utilizing only 80% of the rated output. Signal circuits shall each be loaded no more than 80% of their rated capacity. All modules and drivers must be able to withstand prolonged short circuits in the field wiring, either line-to-line or line-to-ground, without damage.

G. **Emergency Power Supply:** Components include batteries, charger, and automatic transfer circuitry.

1. **Batteries:** Shall be completely maintenance free, sealed lead acid type. Battery nominal life expectancy of 4 years, minimum, is required. Battery voltage and capacity shall be determined by the measured load calculations required by the FACP and related connected equipment. Batteries must be labeled in a permanent way with install date.
2. **Battery Charger:** Solid state, fully automatic, variable-charging-rate type. Provide capacity for 150% of the connected system load while maintaining batteries at full charge. If batteries are fully discharged, the charger charges them completely within twenty four hours. Charger output is supervised as part of system power supply supervision.
3. **Integral Automatic Transfer Switch:** Transfers the load to the battery without

loss of signals or status indications when normal power fails.

**H. Network Interface Capability:** The FACP and any additional specific equipment/hardware, required by the selected manufacture, must guarantee network interface capability with Simplexgrinnell SURguard receiver and Truesite Workstation program.

**I. Enclosures:** The FACP shall be housed in a UL listed cabinet suitable for surface or semi-flush mounting. Cabinet and front shall be corrosion protected, given a rust-resistant prime coat, and manufacturer's standard finish. The door shall provide a key lock and shall include a glass or other transparent opening for viewing of all indicators. For convenience, the door may be hinged on either the right or left side (field selectable). Where multiple enclosures are required in the same area, the cabinets shall all be the same size and color. Cabinet doors **must be electrically bonded** to enclosure it serves.

**K. General Requirements:**

1. A copy of the final building floor plans with all device locations and assigned system addresses shall be permanently mounted or stored at the location of the main FACP. All AV circuit EOL's, riser cabinets, and Isolation Modules shall also be included on these drawings. A separate sheet shall be provided for each floor. Sheets shall be laminated. Provide legend for symbols.
2. All external modules required to be mounted at the main FACP location shall be housed in a UL listed cabinet suitable for surface or semi flush mounting. Cabinet and front shall be corrosion protected, given a rust resistant prime coat, and manufacturer's standard finish. The door shall provide a key lock. For convenience, the door may be hinged on either the right or left side (field selectable). Where multiple enclosures are required in the same area, the cabinets shall all be the same size and color. Cabinet doors **must be electrically bonded** to enclosure it serves.
3. The system shall be new and furnished with a warranty (parts & labor) of at least one year from the date of final inspection and acceptance by the Owner. Equipment, initiating devices, and alarm appliances shall be arranged as described in the Drawings; annunciator zones shall be configured as described in the Drawings.
4. All system components shall be attached to walls and ceiling/floor assemblies and shall be held firmly in place (*e.g.*, **detectors shall not be supported solely by suspended ceilings**). Fasteners and supports shall be adequate to support the required load. Adhesives are not permitted to mount fire alarm system components to building surfaces or structure. All junction boxes shall have covers, where feasible EOL resistors shall have their own dedicated labeled junction box.
5. Loops shall be confined to one floor of coverage and shall not include any devices/modules located or serving other floor areas of coverage. Loop 1 shall be assigned to the lowest elevation level of the building. Loop numbers shall

## APPENDIX D – FIRE ALARM PERFORMANCE GUIDELINES

increment with elevation levels of the building floors. Device numbering starts the loop with address 001 and increments sequentially accordingly as electrically connected in the circuit to the return of the loop.

**Note:** With the written prior approval of JMU Life Safety, multistory buildings with small footprints may be allowed more than one floor per loop.

6. The FACP must have an Alarm Silence switch, and be equipped with the Subsequent Alarm (alarm resound) feature. Any remote annunciators or graphic displays located away from the alarm area must also include an audible signal with alarm resound feature and must be silence- able from the main panel.
7. A supervised programmable "Hot Key" for defeating or bypassing all AV circuits, including sounder base units, must be provided in the FACP. The switch must indicate "Normal" or "Off Normal" position.
8. If the system design includes any type of door control features, a supervised programmable "Hot Key" for defeating or bypassing all door hold open circuits and fire shutter doors or smoke curtains must be provided in the FACP. The switch must indicate "Normal" or "Off Normal" position.
9. If the system design includes any elevator controlling equipment, a supervised programmable "Hot Key" for defeating or bypassing all elevator capture and shunt trip features must be provided in the FACP. The switch must indicate "Normal" or "Off Normal" position.
10. If the system design includes AHU shutdown or smoke removal startup, silencing the alarm (without resetting) must not reverse them. A supervised programmable "Hot Key" for all AHU Shutdown Defeat modules must be provided in the FACP. The switch must indicate "Normal" or "Off Normal" position. In addition, provide supervised Hand-Off-Auto switch(es) at the FACP for any building smoke control equipment (pressurization, smoke purge or exhaust fans).
11. The coverage of each fire alarm loop as described in the Drawings shall be indicated on the FACP and any remote annunciator. This may be accomplished by engraved labels, framed directories, and/or graphic displays. Label tape or handwritten labels are not acceptable.
12. Installer shall program a piezo inhibit function for all trouble and supervisory conditions.

### **L. Input Power Requirements:**

1. All fire alarm equipment 120 VAC supply power shall be fed from the facility "Emergency Power" circuit if available. Systems are to be provided with a separate and independent source of emergency power. Switching to emergency power during alarm shall not cause signal drop-out. Batteries must meet the appropriate NFPA capacity requirements, with a 25% safety factor. This requirement is in effect even if generator power is supplied to the Fire Alarm Control Panel.

## APPENDIX D – FIRE ALARM PERFORMANCE GUIDELINES

- a) Provide an engraved label in the FACP and at any expander panels identifying its 120 VAC power source. This label shall include panel board location, identification and circuit number.
2. Provide 120V receptacles for technician use at the main panel.

### LI. Wiring:

1. Style 7 Circuits Required: Systems with one or more addressable sub-panels that (1) have an integral addressable loop controller, or (2) monitor multiple conventional initiation zones, shall comply with the NFPA 72 requirements for Style 6 circuits.
2. All wiring shall be color coded and labeled inside the FACP, which shall be maintained throughout the system, without color change in any wire run.

<u>Addressable Devices</u>	<u>Approved Manufacture</u>
Signal Line Circuit	<u>Data</u> Any jacket with
cable	Red(+)/Black(-) Red
Alarm Indicating Appliance Circuits	Jacket Red(+)/Black (-)

3. All wiring and cable must be in EMT, 3/4" minimum diameter, unless indicated otherwise on the Drawings or elsewhere in the Specifications. All fire alarm system raceway, couplings, and connectors must meet the performance and installation requirements of Section 16000 "RACEWAYS". Couplings shall be steel compression type and connectors shall be steel compression type with insulated throats.
4. All wiring shall be checked for grounds, opens, and shorts, prior to termination at panels and installation of detector heads. The minimum resistance to ground or between any two conductors shall be ten megohms (10 MW), as verified with a megger. Provide advance notice to the A/E of these tests.

### **3.2 DIGITAL ALARM COMMUNICATOR TRANSMITTERS (DACT'S)**

- A. **Remote Transmissions from non network buildings:** Provide a Digital Alarm Communicator Transmitter (DACT) which is fully compatible with the Owner's Proprietary alarm receiving equipment or the listed central station as indicated on the Drawings. The DACT must be capable of interfacing with the FACP. The following signals, in order of precedence shall be reported as applicable:
  1. Fire
  2. Trouble
  3. Supervisory
- B. The DACT shall be capable of and equipped with:
  - a) 2-channel minimum,
  - b) Backup batteries with an automatic battery charging circuit,
  - c) Capable of performing a self test every 24 hours and generating a 24 hour test report to the receiving station equipment,
  - d) Any failure shall initiate a trouble condition, The "Trouble" signal for AC power loss must not be sent unless maintained for 1 hour or more to avoid nuisance transmissions due to momentary 120 VAC power outages or alarm verification cycles,
  - e) Dual phone line capability,
  - f) Network connectivity,
  - g) Any off-normal condition shall be report to the DACT for transmission,

2. DACT's requiring programming of Electronic memory (i.e, PROM flashing/burning type), are not acceptable.

### 3.3 AUXILIARY POWER SUPPLY PANELS (APS)

- A. **Auxiliary Power Supply(ies) - General:** Typical applications for usage of APS panels include but are not limited to: notification appliance circuits (NAC), door holders, control relays, and repeater power extenders.
- B. **APS - Minimum Requirements:** All APS(s) shall operate on 120 VAC, 60 Hz and shall have a continuous rating adequate to power all equipment and functions in full alarm continuously utilizing no more than 80% of the total rated ampere output capacity. All modules and drivers must be able to withstand prolonged short circuits in the field wiring, either line-to-line or line-to-ground, without damage. All APS's shall be capable of providing the following general requirements, features, and functions when utilized as an integral part of the system:
  1. Each APS utilized in the system shall be supervised **individually** by the FACP. This may be accomplished by:
    - a) On board means of setting the FACP assigned address.
    - b) Utilization of a system addressable monitor type module.
  2. Each APS must capable of supervising all input/output circuitry with on board LED's for specific fault indications. On board supervision includes:
    - a) AC power failure,
    - b) Battery fault,
    - c) Ground fault,
    - d) Individual output circuit faults,
    - e) And any auxiliary power output circuits.
  3. Shall provide multiple regulated and conditioned +24VDC output circuits.
  4. Shall provide at least (1) one +24VDC auxiliary type output.
  5. Shall be capable of being externally triggered or initiated by the FACP, via an addressable control module, for all required output activations.
  6. Shall provide at least (1) Form "C" dry contact or other on board form of dry contact output that will change states during any fault condition detected, for connection to (1) one addressable monitoring device for individual APS, FACP supervision.

## APPENDIX D – FIRE ALARM PERFORMANCE GUIDELINES

7. Output circuits shall have the capability of being selectively disabled, via on board switch configurations, during any AC power failures.
- C. **Enclosures:** The APS shall be housed in a UL listed cabinet suitable for surface or semi-flush mounting. Cabinet and front shall be corrosion protected, given a rust-resistant prime coat, and manufacturer's standard finish. The door shall provide a key lock. For convenience, the door may be hinged on either the right or left side (field selectable). Where multiple enclosures are required in the same area, the cabinets shall all be the same size and color. **Cabinet doors must be electrically bonded to enclosure it serves.**

### 3.4 ANNUNCIATION DEVICES

- A. **Alarm Notification Appliances - General:** Both audible and visible alarm signals shall be provided. Visible signals must be the strobe (flash discharge) type, with white or clear lens.
  1. All and each AV circuits shall have a supervised means to individually bypass.
  2. In ADA designated locations, where placement of additional specialized AV devices are required, those device shall follow the action of the room sounder base.
- B. **Audible (Horns/Speaker):** Shall be located as shown on the Drawings; sounders located outdoors or indoor locations subject to moisture, shall be listed for use in wet locations. Electric sounders shall have the following specifications:
  1. **Voltage:** Horns shall operate on 24 VDC nominal.
  2. **Programming:** Horns shall be field selectable without the use of special tools, to provide slow whoop, continuous, three pulse temporal or interrupted tones or voice. Evacuation signal shall be the ANSI 53.41 three-pulse temporal pattern. Animal quarters and patient areas must be served by chimes. Animal quarters shall have means to bypass chimes with supervised override switch to facilitate testing of system.
  3. **Mounting:** All weatherproof devices shall be sealed via an approved method before mounting devices.
- C. **Visual (Strobes):** Strobes shall be located as shown on the Drawings. Strobes indicated for use exterior to the building or indoor locations subject to moisture, shall be mounted at the indicated elevation and listed for use in wet locations.
  1. **Voltage:** Strobe lights shall operate on 24 VDC nominal.
  2. **Mounting:** All weatherproof devices shall be sealed via an approved method before mounting devices.
- D. **Audible/Visual Combination Devices:** Shall be located as shown on the Drawings and shall comply with all applicable requirements for both Audible and Visual.

## APPENDIX D – FIRE ALARM PERFORMANCE GUIDELINES

- E. **Sounder Bases:** Where indicated on the Drawings, provide bases with a built-in (local) sounder rated at 85dB minimum. Configure sounder bases such that sounders are activated under conditions as described or otherwise indicated on the Drawings. All areas that require the installation of Sounder Base Units shall be configured to function as follows:
1. **Voltage:** The sounder base power shall be supervised by the FACP.
  2. **Programming:** All areas that require the installation of Sounder Base Unit Devices shall be programmed to perform the following sequence of operation:
    - a) The sounder base initiating device shall report the 1<sup>st</sup> alarm condition locally and to the FACP, which in turn shall sound that individual sounder base and any special ADA AV device additionally required in that area ONLY and be reset by fanning the detector.
    - b) The 2<sup>nd</sup> alarm received by the FACP shall initiate standard evacuation procedures.
    - c) All sounder bases shall sound on any general alarm condition initiated by any common area initiating device including: smoke detectors, thermal (heat) detectors, manual stations, water-flow, duct detectors( except when programmed as a supervisory), or by a 2<sup>nd</sup> or subsequent alarm from any other sounder base initiating device.
    - d) Individual sounder bases must and be capable of alarm resound.
- F. **Bells:** Shall be 10" diameter vibrating type located as shown on the Drawings; bells located outdoors shall be listed for use in wet locations. Bells shall have the following specifications:
1. **Voltage:** Bells shall operate on 24 VDC nominal.
  2. **Mounting:** Provide flush mounting devices. Bell mounting elevation shall be as described on the Drawings.
- G. **Device Remote Annunciation:** Remote annunciator indicator lights (RAIL's) shall be provided in locations where indicated on the Drawings. In addition, RAIL's shall have the following features:
1. RAIL's shall be provided with a key type switch for testing of the annunciated device. Testing device activation shall be accomplished through direct hardwiring to the device NOT through software activation, be program activated, or by any external logic controlling.
  2. **Voltage:** RAIL's shall operate on 24 VDC nominal.
  3. **Mounting:** Device shall be mounted in/to the wall at the same height requirements per NFPA72 as A/V devices. Do not mount in ceiling tiles. Devices shall be located in the nearest corridor or public area and identified by an engraved affixed label.
- H. **Alphanumeric Display Annunciators:** Shall be supervised and remotely located as specified on the Drawings.

1. Unit shall have a back-lit LCD display containing a minimum of (80) eighty characters for alarm annunciation in clear English text.
  2. The LCD annunciator shall display all alarm, trouble, and supervisory conditions in the system and provide duplicate “active” manual switching functions of the FACP, including: Acknowledging, Signal Silencing, System Reset, and Test/Drill.
  3. The annunciator shall be in a lockable cabinet keyed the same as the FACP.
  4. **Connections:** The annunciator shall connect to a remote microphone unit for firefighter operation and repeater units where such are indicated on the Drawings.
  5. **System Capacity:** The system shall allow a minimum of one LCD annunciator. In addition to annunciation functions, each LCD annunciator shall be capable of the following software programmed system functions: Acknowledge, Signal Silence and Reset and bypass hotkeys.
- I. **Serially Connected LED Annunciator:** Annunciator shall communicate with the fire alarm control panel and shall individually annunciate all zones in the system. System zones shall be as indicated on the Drawings.
1. **Annunciator Indicators:** The annunciator shall provide a red Alarm LED , yellow Trouble LED, and Supervisory Trouble LED. The annunciator shall also have an AC power LED, local piezo sounder, local acknowledge/lamp test switch, and custom zone/function identification labels. Annunciator switches may be used for System control such as, Global Acknowledge, Global Signal Silence, and Global System Reset. All annunciator switches and indicators shall be software programmable, if programmed they must be labeled.
  2. The annunciator shall be in a key lockable cabinet.
- J. **LED Graphic Display Panel:** In high rise, complex, or higher square footage facilities, a Graphic Annunciator shall be installed. A display graphic will be provided by the contractor, or JMU life safety.
1. **Annunciator Indicators:** The annunciator shall provide a red Alarm LED, yellow Trouble LED, and Supervisory Trouble LED, and indicate system operational status. The annunciator shall also have an "Ac power" LED, local piezo sounder, local acknowledge/lamp test switch, and custom zone/function identification labels. Annunciator switches may be used for System control such as, Global Acknowledge, Global Signal Silence, and Global System Reset. All annunciator switches and indicators shall be software programmable. Piezo inhibit functions shall be programmed for all trouble and supervisory conditions. Bypass buttons if applicable must be labeled and functional.
  3. The annunciator shall be in a key lockable cabinet.

### 3.5 EMERGENCY VOICE/ALARM COMMUNICATIONS

- A. Where emergency voice communications systems are indicated on the Drawings, provide systems with the following characteristics and features:
1. One-way voice/alarm systems shall be dual channel, permitting the application of an evacuation signal to one or more zones simultaneously with manual voice paging to the other zones. Communication zones shall be capable of being selected in any combination.
  2. Provide duplicate tone generators, pre-amps, and power amplifiers. Failure of any of these shall automatically result in the defective unit being promptly switched off-line and replaced with the backup so that operation as described elsewhere is uninterrupted.
  3. Normal amplifier power shall be a minimum of 125% RMS of the full speaker load, per channel. For purposes of this calculation, use the amplifier's continuous two-tone output rating and assume one watt per speaker. A copy of this calculation shall be included with the submittals.
  4. Communications equipment shall be housed in the FACP and/or in adjacent cabinets(s) of matching appearance and size. All connections between the FACP and the voice communications panel shall be made via cables or harness assemblies, which have been prewired and tested by the system manufacturer.
  5. Evacuation signal shall be a "three-pulse" temporal pattern complying with ANSI S3.41-1990 accompanied by voice.
  6. Existing Wiring: Where existing wiring is reused provide a written guarantee that it is acceptable for use with the equipment provided under this contract. Existing wiring may be used only with the owner's written permission.

### 3.6 INITIATING DEVICES

- A. **Non-Addressable Type Devices – General:** In some cases, the use of non-addressable devices with an addressable monitor type module is acceptable. These areas shall be identified on the Drawing with the acceptable device type for the specific locations. Affected areas may include where:
1. **Temperature Ratings:** Non-addressable devices shall be utilized in unconditioned spaces where temperature and/or humidity ranges can exceed the manufactures recommended ratings of the electronic component circuitry for proper operation of addressable type devices. Acceptable substitutions with these non-addressable type devices may include:
    - a) Thermal Detection Devices
    - b) Manual Stations

- c) Tamper Switches
- d) Duct Smoke Detectors

2. **Harsh Environments:** Areas that is environmentally detrimental to addressable type devices. Acceptable substitutions with these conventional type devices may include:

- a) Explosion proof devices
- b) Flame detection devices

3. **Mounting:** When using non-addressable type devices monitored with an addressable monitor type modules. Mount addressable monitor type modules in nearest conditioned space and indicate its address on the outside of the enclosure by means of a label.

**B. Addressable Type Devices – General:** Unless otherwise indicated on the Drawings all initiating devices shall be individually addressable and labeled with **accurate descriptions**. Addressable devices shall comply with the following general requirements:

1. **Address Setting:** Addressable devices shall provide an address setting means inherent within the device. Devices, which are addressed by the FACP are also acceptable.
2. **Device Identification:** Addressable devices shall store an internal specific identifying “type” code that the FACP shall use to identify the type of device.
3. **Temperature Ratings:** Addressable devices shall not be utilized in unconditioned spaces where temperature and/or humidity ranges can exceed the manufactures recommended ratings of the electronic component circuitry for proper operation.
4. **Operational Indications:** Addressable devices shall provide powered LED’s. LED’s shall flash under normal conditions, indicating that the device is operational and in regular communication with the FACP. LED’s shall be placed into steady illumination by the FACP to indicate that an alarm or off normal condition has been detected. The flashing mode operation of the detector LED’s shall be optional through the system field program. An output connection shall also be provided in the device base to connect an external/remote LED indication of an alarm or off normal condition in specific required locations.
5. **Device Mounting:** Unless otherwise specified all devices shall provide the following mounting criteria:
  - a) All detectors shall be ceiling-mount. Any device mounted in excess of 12’ft shall have a RAIL unit with device address affixed at eye level in proximity.
  - b) All other addressable devices, remote LED indicators, remote test switches, and isolation modules shall be wall-mount type.
  - c) **Devices shall not be mounted with cordless drill drives to include terminal wiring connections.**

C. **Addressable Manual Stations (Pull Stations):** Unless otherwise indicated on the Drawings all pull stations shall comply with the following additional requirements:

1. All pull stations shall have a dual-action mechanism requiring two actions to initiate an alarm condition. Labels with device address must be affixed to the unit.
2. All pull stations shall provide a clear visual indication when operated, and shall utilize a key type reset for restoral to normal operation. Pull stations that employ a glass break rod are not acceptable.
3. An LED shall be provided that shall flash under normal conditions, indicating that the control module is operational and is in regular communication with the control panel.
4. **Construction:** Pull stations shall be constructed of Lexan or other material suitable to the installation environment with clearly visible operating instructions provided on the cover. The word FIRE shall appear on the front of the stations in raised letters, 1.75 inches or larger. Stations shall be suitable for surface mounting or semi flush mounting as shown on the plans.
5. In facilities that are fully sprinklered the University requires additional manual stations located at all exits from the building and at all exits per floor within the building (including rooms that only have outside entrances with no access into the facility such as outside mechanical, electrical, and sprinkler riser rooms etc.).

CI. **Addressable Smoke Detectors:** Unless otherwise indicated on the Drawings all smoke detectors shall comply with the following additional requirements:

1. All smoke detector sensitivity shall be set through the FACP and shall be capable of adjustment in the field through the field programming of the system. Sensitivity shall be capable of being automatically adjusted by the FACP program on a time-of-day basis. Devices shall be capable of reporting obscuration levels and maintenance alerts when any smoke/duct detector approaches 80% of its alarm threshold due to gradual contamination.
2. In facilities that are fully sprinklered the University requires additional smoke detection in telecommunication closets, electrical closets, and rooms that contain significant electronic equipment such as computer server rooms and audio and/or video projection rooms.
3. Must be the plug-in/snap in type, each having a separate base, to facilitate replacement and maintenance. When installed in a room, detectors shall be oriented so their alarm light is visible from the nearest door to the corridor. All lights shall be oriented similarly.
  - a) In areas where smoke detector placements are not easily visible a Remote Alarm Indicator Light (RAIL) must be provided, or in areas that will allow, a RED circle shall be painted on the floor directly below the detector with the device system address.

4. Spot type smoke detectors mounted within 12 feet of a walking surface shall have their built-in locking device activated.
5. Unless suitably protected against dust, paint, etc., detectors shall not be installed until the final construction clean-up has been completed. **Contaminated detectors must be REPLACED by the Contractor at no additional cost to the Owner.**
6. Identification of individual detectors is required. These device numbers, which must also be shown on the shop drawings, shall be permanently affixed to the detector base. Device labels may not be affixed to the device. Identification labels must be printed labels with black lettering on a clear background. Handwritten labels or labels made from embossed tape are not acceptable.
7. Smoke detector guards, where indicated on the Drawings shall be Listed for use with the specific model of smoke detector being protected. All smoke detector guards are to have a separate base which must be very securely anchored to wall or ceiling. The cover must be readily removable by the Owner for periodic detector cleaning and servicing but, to prevent unauthorized entry, must be secured to the base by a lock or tamper resistant screws approved by the A/E. Metal guards must be 16 gauge or heavier steel.
8. Devices used for elevator capture are identified on the Drawings by the designation EL adjacent to the detector. Primary and/or alternate recall points are indicated on the drawings. Elevator capture or control signals must come from the FACP as relayed by control modules. Use of detector auxiliary contacts for elevator capture is not acceptable or permitted.

### 6. ALARM VERIFICATION FOR SMOKE DETECTORS

1. The fire alarm system shall be equipped with logic method of verifying the presence of smoke.
2. Alarms from other than spot type smoke detectors must not be delayed by Alarm Verification. Alarm Verification is NOT to be applied to linear beam, duct smoke detectors, elevator lobby and machine room detectors, nor to any software configured "cross zoned" detection devices. When programming the system, activate the automatic drift compensation feature for all spot- type smoke detectors. Whether or not to activate the alarm verification feature for such detectors is to be determined by the design engineer/ owner's representative.

NOTE: Most applications of analog addressable smoke detectors do not require alarm verification to prevent nuisance alarms, unless there are transient ambient conditions, which may create problems. A short operational test period will usually provide information to determine this.

3. Systems with Alarm Verification must be permanently labeled to indicate that fact.
4. While a verification cycle is in progress, an alarm, which occurs on another zone,

## APPENDIX D – FIRE ALARM PERFORMANCE GUIDELINES

must not cause the verification cycle under way to be restarted or extended. It may have the same effect on the system as a verified alarm.

5. The equipment must be Listed for Alarm Verification purposes. It must either be installed at the factory, or field programmable and tested by the Manufacturer's authorized representative.

**F. Addressable Thermal Detectors (Heat):** Unless otherwise indicated on the Drawings all addressable heat detectors shall comply with the design criteria of the conditioned protected space.

**G Addressable Duct Smoke Detectors:** Unless otherwise indicated on the Drawings all duct smoke detectors shall be the photoelectric type.

1. **General:** The contractor shall mark the direction of airflow on the duct at each duct detector location. Provide duct access doors.

- a) Air duct/plenum detectors must have device remote annunciation. See section 3.3.G above for guidelines pertaining to these specific devices.

- b) These detectors shall be installed in a manner that provides suitable access for required periodic cleaning and calibration.

- c) Contractor shall program Duct Detectors for auto restore with a 30 second time delay by means of a 2 part custom control equation.

2. **Air Sampling Tubes:** The preferred method for providing support is to extend the intake tube through the far side of the duct, seal around the tube where it penetrates the duct wall, and plug the end with a rubber stopper. This facilitates visual inspection, intake tube cleaning, and injection of smoke or equivalent aerosol for testing the detector. Those over 36 inches long must be provided with center support.

### **3.7 MONITOR AND CONTROL DEVICES**

**A. Addressable Dry Contact Monitor Modules:** Addressable Monitor Modules shall be provided to connect (1) one non-addressable device or to supervise a non-addressable IDC zone (either Style D or Style B) of conventional type alarm initiating devices (any Normally Open [N.O.] dry contact device) to one of the Fire Alarm Control Panel Signaling Line Circuit Loops. Monitor modules shall be installed as required by the system configuration. All required monitor modules must be shown on the Drawings.

1. **Indication of Operation:** Unless otherwise indicated on the Drawings an LED shall be provided that shall flash under normal conditions, indicating that the Monitor Module is operational and in regular communication with the FACP.

2. **Mounting Requirements:** Shall be mounted at the same height requirement as Notification Appliance devices in a clearly visible location.

**B. Addressable Control Modules:** Addressable Control Modules shall be provided to

## APPENDIX D – FIRE ALARM PERFORMANCE GUIDELINES

supervise and control the operation of (1) one conventional Notification Appliance Circuit (NAC) of compatible, 24 VDC powered, polarized Audio/Visual (A/V) Notification Appliances. For fan shutdown and other auxiliary control functions, the control module may be set to operate as a dry contract relay. The control module shall provide address-setting means using decimal switches and shall also store an internal identifying code that the control panel shall use to identify the type of device. An LED shall be provided that shall flash under normal conditions, indicating that the control module is operational and is in regular communication with the control panel. Control modules shall be rated for the load they control. (Inductive Loads require inductive rated modules.)

1. **Mounting Requirements:** Shall be mounted at the same height requirement as Notification Appliance devices in a clearly visible location.
  2. **Configuration:** The control module NAC circuit should be wired for Class A operation with up to 1 Amp of inductive A/V signal, or 2 Amps of resistive A/V signal operation, or as a dry contact (Form C) relay. The control module should be suitable for pilot duty applications and rated for a minimum of 0.6 amps at 30 VDC. The relay coil should be magnetically latched to reduce wiring connection requirements, and to insure that 100% of all auxiliary relay or NAC's may be energized at the same time on the same pair of wires.
  3. **Power Source:** Audio/visual power shall be provided by a separate supervised power loop from the main fire alarm control panel or from a supervised, UL listed remote power supply. A/V power sources and connections are not shown on the Drawings.
  4. Supervision required: The connection between individual addressable modules and their contact type initiating device(s) must be supervised.
- C. **Isolator Modules:** Isolator Modules shall be provided to automatically isolate wire-to-wire short circuits on an SLC loop. The Isolator Module shall limit the number of modules or detectors that may be rendered inoperative by a short circuit fault on the SLC Loop.
1. **Operation:** Isolator Modules shall operate such that if a wire-to-wire short occurs, the Isolator Module shall automatically open-circuit (disconnect) the SLC loop. When the short circuit condition is corrected, the Isolator Module shall automatically reconnect the isolated section. The Isolator Module shall not require any address setting, and its operations shall be totally automatic. It shall not be necessary to replace or reset an Isolator Module after its normal operation.
  2. To minimize the impact of a wiring fault on the system, isolation modules must be provided as follows:
    - a) After each 50 devices/control points on any addressable circuit.
    - b) For each circuit extending outside the building.
    - c) In the FACP, at each end of the loop.

- d) On loops containing less than the 25 devices place an isolator at each end of the loop and one in the electrical center of the loop.
3. **Mounting:** The Isolator Module shall be wall mounted at the same height as A/V devices in a clearly viewable area in corridors. It shall provide a single LED that shall flash to indicate that the Isolator is operational and shall illuminate steadily to indicate that a short circuit condition has been detected and isolated.

### 3.8 MISCELLANEOUS SYSTEM ITEMS

- A. **Door Hold-Open Magnets:** Door hold open magnets shall be furnished with keepers, door chains, and other accessories as required to properly hold open doors as indicated on the Drawings. Holding force of the magnet shall be appropriate for the door to be held open. Door hold open magnets shall operate in a fail-safe manner, *i.e.*, the door shall release in event of a failure of voltage to the device.
  1. **Power Supply:** Door hold open magnets shall be configured to operate from a nominal 24 VDC system as supplied by the FACP or other power supply listed for the purpose. All hold open magnet supply sources, whether a part of the FACP or whether derived from a separate power supply, shall be supervised. Door hold open magnets which use step-down transformers, 120 VAC, or local relays are acceptable. Magnets shall release on a power failure.
  2. **Device box support:** Door hold open magnet device boxes shall be securely attached to the building structure by effective means. Boxes attached directly to only one metal stud or boxes supported by means of expansion type fasteners are not acceptable.
  3. Wall mounted magnetic door holders and separate heavy-duty closers shall be used, instead of combination door control units. The electromagnets shall be controlled by the building's smoke detection system FACP. Individual smoke detector auxiliary contacts shall not be used to release door holders.
- B. **Rolling Fire or Smoke Doors:** Rolling Fire or Smoke Doors shall be motor operated. No manual reset doors are permitted.
  1. **Remote Power Supplies:** Where remote power supplies are required, they shall meet the same requirements as those for the main fire alarm control panel, including the requirements for batteries and supervision.
  2. **Keys and Locks:** All panels, terminal cabinets, and pull stations shall be keyed alike. Coordinate key/lock with the Owner's requirements.
- C. **Building Automatic Door Locking Systems Interface Requirements:**

1. Automatic door locks controlled by the system must be either fail-safe magnetic

## APPENDIX D – FIRE ALARM PERFORMANCE GUIDELINES

locks or fail- safe electro-mechanical with reverse bevel dead bolts.

2. All lock protected doors must immediately unlock upon fire alarm, loss of AC power, disablement of the fire alarm system (defined as loss of 24 VDC power) or upon manual operation of an unlocked supervised switch at a constantly attended location.

### D. Spare Parts Requirements:

1. **Spare Parts:** Provide the following spare parts with the system, each individually packaged and labeled. For multi-building projects, calculate separately for each building:

Fuses	1 of each size used in
Isolation	system 2% of installed
Modules Manual	quantity
Stations Indoor	2% of installed
Horns/Strobes	quantity 10% of
Spot Smoke Detectors, Bases	installed quantity 5%
	of installed quantity

2% of installed quantity

Monitor/Relay Modules                      5% of installed quantity

2. Increase decimal quantities of spare parts to the next higher whole number. For example if a system has 20 spot-type smoke detectors provide 2 spare detectors with bases.

## **PART 4 SYSTEM TESTING & CERTIFICATION**

### **4.1 Contractor/Installer Testing and Certification**

- A. Upon successful completion of the Pre-final Inspection, per the programming checklist, and correction of all deficiencies, the manufacturer’s authorized representative shall issue a test report to: the A/E and the Facilities Management Life Safety Shop detailing and certifying the test, including those requirements as specified in this document.

### **4.2 A/E Testing and Certification**

- A. **A/E System Inspection:** In an effort to expedite the inspection process for projects already seriously behind schedule, the A/E can request JMU Construction Management to schedule the Facilities Management Life Safety Shop to witness and assist with acceptance commissioning, field inspection testing, to be performed in conjunction with the A/E inspection. This is not recommended and has proven to produce lengthy punch-lists and numerous re-inspections by the Contractor.
- B. Once the A/E has inspected, tested and is satisfied the system is 100% operational, and has met all aspects of the A/E design, the A/E shall notify JMU Construction Management to schedule the Facilities Management Life Safety Shop owner acceptance commissioning inspection and testing, this can be combined into the SMFO inspection. At that time the A/E shall also and submit the following to the Life Safety Shop:
  - The latest copy of Detector Sensitivity Report.
  - A printout of the current installed site-specific database/pointslist.
  - Signed copy of the NFPA “Record of Completion” form per NFPA 72.
  - Signed copy of the contractors pre-inspection checklist.
  - Current copy of as-built drawings with correct room numbers and device system addresses. Room numbers must be installed.
  - Copy of battery calculations.
  - Copy of record for the Notification Appliance Circuit voltage measurements taken at the EOL devices during the A/E test. Take readings at the start of the test and every 15 minutes during NAC test. Test shall be 30 minutes minimum. Test shall be conducted with AC power off and under battery power only.

**4.3 Owner Testing and Inspection**

- A. Database and Drawing Inspection:** The Facilities Management Life Safety Shop will require all the above and a minimum of 3 days for review of the system database and drawing review, prior to scheduling any on-site test.
1. Upon completion of the system database and drawing review any discrepancies will be documented and forwarded to JMU Construction Management requiring action and corrections from the A/E's system installer/programmer. When the required actions and corrections have been addressed and performed, a corrected printout of the installed site-specific database and drawings shall be forwarded to the Life Safety Shop for re-review. After review and satisfaction that the corrections have been made, then and only then, will the Life Safety Shop schedule their field inspection and test. The Life Safety Shop will notify JMU Construction Management of the scheduled date and time.
- B. Owner acceptance commissioning field inspection:** A 100% fully functional test of all aspects of the system will be conducted. Therefore, it is expected that the system shall be complete in all aspects. Each function and aspect of system will be tested along with each and every initiating device. Also, all other system functions shall be verified, including but not limited to (where applicable): elevator capture features, control of HVAC systems, door locks, pressurization fans, fire or smoke doors/dampers/shutters, sprinkler systems, etc. The trades' personnel representing the various aspects must be present. The A/E representative does not have to attend but may attend if so desired. **The fire alarm vendor's technician who programmed the system must be present.**

**NOTE:** If at any time, during the owner's acceptance commissioning field inspection and test, it appears that the installation contractor has not performed a prior 100% performance test, the current test will be terminated and rescheduled.

1. Upon completion of the acceptance commissioning field inspection and test, the Facilities Management Life Safety Shop will forward a list of discrepancies in the form of a formal "Punch List" to JMU Construction Management for comment and/or inclusion in the A/E's punch- list of items requiring action and/or corrections from the effected systems contractors/installers. Once the contractors/installers have corrected these items, the A/E shall notify JMU Construction Management and schedule a re-inspection by the Facilities Management Life Safety Shop & SMFO. When the systems are verified to be satisfactory by the Life Safety Shop, the A/E shall be notified by JMU Construction Management to schedule an inspection and test. On or before the day of the Office of State Fire Marshal's test the following must be completed and/or provided to the Owner:
  - Copy of current database installed in the system on CD or Flash drive.
  - All drawings shall be posted.
  - All spare parts and test equipment as described in the specification shall be turned over to the owner.
  - All training requirements shall be met or scheduled.
  - All required software on CD or disk shall be turned over to the owner.
  - All certifications.

## APPENDIX D – FIRE ALARM PERFORMANCE GUIDELINES

- A new signed and dated NFPA “Record of Completion” form per NFPA 72, if required.
- The FACP shall be turned on but not reporting to the JMU Central Alarm Receiving System (CARS) until final acceptance.

### 4.4 System Acceptance

A. **Office of State Fire Marshal:** The above items must be completed on the day of/ before the Office of State Fire Marshal inspection. Upon completion of Office of State Fire Marshal inspection any items or discrepancies must be corrected. When this obligation has been met the warranty shall begin on the day the A/E notifies JMU Facilities Planning and construction and the Life Safety Shop to that effect.

1. **Beneficial or partial occupancy exceptions shall require the system contractor/installer to remain responsible for the "live" system.** A daytime and after hours contact list shall be provided to the Life Safety Shop which will include the names and phone numbers for three (3) responsible individuals until Final acceptance has been granted.

B. **JMU Central Alarm Receiving System (CARS) Activation:** The Life Safety Shop will activate the FACP account in the JMU Central Alarm Receiving System (CARS). In the event of malfunctions or excessive nuisance alarms, the Contractor must take prompt corrective action. The Owner may require a repeat of the Contractor's 100% system test, or other inspections. Continued improper performance during the warranty period shall be cause to require the Contractor to remove the system and replace it.

C. The contractor shall notify the supervisor of the Facilities Management Life Safety Shop prior to performing any work on the system after the final acceptance by the Office of State Fire Marshal .

## PART 5 SYSTEM DOCUMENTATION, TRAINING, & MAINTENANCE

### 5.1 System Documentation

A. The Contractor/Installer shall provide the Owner: with the following:

1. A current factory approved certification/ training schedule for the specific system installed.
2. **As-Built Drawings:** Submit (1) bound full size set, and (1) one 11”x17” set, and an electronic copy in format compatible with the most recent release of Adobe, of scaled architectural floor plans depicting final device/module and equipment locations with corresponding system addresses, all circuiting, and pathways, and terminal cabinet locations. Include wiring and riser diagrams with actual field measured battery calculations for the main fire alarm panel and all individual circuits of the Notification Appliance Circuit panels (NAC’s).
  - a) Electrical and Electronic circuit diagrams of all control panels, modules,

## APPENDIX D – FIRE ALARM PERFORMANCE GUIDELINES

annunciators, communications panels, riser panels, etc.

3. Two (2) copies of all software required, both for the installed fire alarm system and for any personal computer (PC) necessary to access the fire alarm system for trouble shooting, programming, modifications, monitoring, de-bugging, or similar functions.
4. Two (2) copies of the complete maintenance, installation, and programming manuals for the installed fire alarm system. If available a CD version is desired and acceptable. Also provide all technical literature on all major parts of the system, including control panels, batteries, detectors, manual stations, alarm indicating appliances, power supplies, and remote alarm transmission means.

B. The Equipment Manufacturer's shall provide the Owner: with the following:

1. Agreement to License and/or factory certification system training for the Facilities Management Life Safety Shop technicians to maintain and service the equipment installed under this contract.
2. Direct access and support for the Facilities Service Life Safety Shop technicians from the Manufacturer's or Factory's Technical Services.

### 5.2 System Training and Maintenance

A. During the design specification review process, the Design Manager and the Life Safety representative will jointly review the proposed specifications to determine if training is required for the proposed life safety system. Training requirements, scheduling, will be coordinated by the Life Safety Division directly with the installation equipment Contractor/Installer and the equipment Vendor/Factory. All cost involved with training travel (transportation, accommodations, meals, etc.) will not be assessed to the Contractor/Installer as part of the contract, but will be funded separately by JMU from allocated reserves.

B. The Equipment Manufacturer's shall provide the Contractor/Installer and/or the Owner: with the following:

1. The schedule of available dates when classes are available to obtain License and/or factory certification system training for the Facilities Management Life Safety Shop technicians to maintain and service the equipment installed under this contract.
2. **Training Content:** Factory/Manufacture classes, training and testing shall provide what is necessary to certify and/or authorize attendees to program and service the fire alarm system installed for this project, including system hardware and software. Additionally, the training shall cover the following topics as a minimum:

a) Preventative maintenance service techniques and schedules, including

## APPENDIX D – FIRE ALARM PERFORMANCE GUIDELINES

historical data trending of alarm and trouble records.

- b) Overall system concepts, capabilities, and functions. Training shall be in depth, so that the owner shall be able to add or delete devices to the system and to take any device out of service and return any device to service without need for Manufacturers approval.
- c) Explanation of all control functions, including training to program and operate the system software.
- d) Manuals, drawings, and technical documentation.
- e) The actual system software used to support the fire alarm system installed for this project shall be provided on CDs or USB, any required “software keys” and/or peripheral hardware to successfully operate the software on the technicians computers shall be provided to the Owner’s technicians upon successful completion of the training.

C. The Contractor/Installer shall provide the Owner: with the following:

1. The contractor shall submit a complete site specific system orientation training schedule including dates, times and location for approval by the owner and engineer. which shall include:
  - a) Preventative maintenance and any special servicing and/or maintenance techniques, including methods and means of troubleshooting and replacement of all field wiring and devices and, methods and procedures used for troubleshooting the main fire alarm control panel, including field peripheral devices as to programming, bussing systems, internal panel and unit wiring, circuitry and interconnections.
  - b) Overall system concepts, capabilities, and functions.
  - c) Explanation of all control functions, input or output.
  - d) Any device and/or equipment locations that are not easily found.
  - e) Any programming peculiarities that is inherent in the system.
2. The Contractor/Installer is responsible for ensuring that the manufacturer's authorized representative shall provide a schedule of the available manufacture certification training for attendance by the Owner's designated employees. The training will include the proper programming procedures, operation of the system, troubleshooting and maintenance aspects, and all required periodic maintenance.
  - a) The authorized representative will coordinate training arrangements with the Owner's schedule.

- b) **Location:** On-site certification training is preferred and JMU will make

## APPENDIX D – FIRE ALARM PERFORMANCE GUIDELINES

available classroom space as needed by the manufacturer. If travel is required, the Life Safety Division will determine the personnel required to be trained.

3. The Contractor/Installer is responsible for ensuring the manufacturer provides the Owner with the following:
  - a) Licenses and/or certifications to maintain and service the equipment installed under this contract.
  - b) Direct access and support for the University Technicians to the Manufacturers Technical Services.
4. **Equipment:** The Contractor/Installer is responsible for providing a list of all required support equipment necessary to support the fire alarm system installed for this project. This list shall include computers (laptop or desktop), software, connecting cables, accessories and auxiliary equipment necessary to effectively operate the life safety system.

### PART 6 ALTERNATES AND ATTACHMENTS

#### 6.1 ALTERNATES

Alternate E1 - Submit a quote for a maintenance contract to provide all maintenance, test, and repair described below and/or in accordance with NFPA-72, "Inspection, Testing, and Maintenance". Include also a quote of unscheduled maintenance/repair, including hourly rates including travel cost, for technicians trained on this equipment, and including an "on call" type response time within one (1) hour from time of notification 24-7, 365 days a year. Submittals that do not identify all post contract maintenance costs will not be accepted. Rates and costs shall be valid for the period of five (5) years after expiration of the warranty. Inspections and testing shall be performed as prescribed below. A preventive maintenance schedule shall be provided by the Contractor that shall describe the protocol for preventive maintenance. The schedule shall include

- a) Quarterly inspections of any radiant energy fire detectors, supervisory signal devices, and water-flow devices. Functional testing of entire system batteries and battery charging circuits.
- b) Semiannual inspections of entire system batteries and battery charging circuits, transient suppressors, control unit trouble signals, emergency voice / alarm communications equipment, remote annunciators, initiating devices, interface equipment, alarm notification appliances, and the digital communicator (DACT). Functional testing of entire system batteries and battery charging circuits, radiant energy fire detectors, water- flow devices and valve tamper switches. systematic examination, adjustment and cleaning of all detectors, manual fire alarm stations, control panels, power supplies, relays, and water flow switches and all accessories of the fire alarm system.

## APPENDIX D – FIRE ALARM PERFORMANCE GUIDELINES

- c) Annual inspection and functional testing of all control equipment, entire system batteries and battery charging circuits, control unit trouble signals, emergency voice / alarm communications equipment, remote annunciators, initiating devices, interface equipment, special hazard equipment, alarm notification appliances, and the digital communicator (DACT).



3. \_\_\_\_\_

**NIGHTS, WEEKENDS, AND HOLIDAYS**

**Name:**

**Phone and or Pager #:**

1. \_\_\_\_\_

2. \_\_\_\_\_

3. \_\_\_\_\_